

Panasonic

Lenses & Accessories
FOR LUMIX S SERIES / LUMIX G SERIES

CHANGING PHOTOGRAPHY
LUMIX



LUMIX

Beyond Top Quality Lenses



LUMIX **S** series lens

LUMIX S PRO Certified by LEICA P06 | LUMIX S P16

Inspired and incessantly driven, LUMIX exceeds the limits of innovation and originality, committed always to its brand philosophy "Creating a New Culture of Photography for a Digital Age". Having pioneered mirrorless camera technologies, LUMIX now steps up to the next level with its lenses. Boasting an extensive line-up and wide-ranging compatibility, the G series offers a combination of excellent mobility and superb image quality. The S series, with advanced optical technologies and mechatronics, represents an additional eye for the imaginative photographer – capturing it all, every subtle detail and nuance – with highly expressive video also opening up totally new layers of reality.



LUMIX **G** series lens

LEICA DG Lens P21 | LUMIX G Lens and X Lens P33

LUMIX S series lens

Our mission is to empower the artist to capture the finest, most subtle details of the subject within every image. Your success? Assured, thanks to superior optical technologies from the same innovators who created LUMIX's DSLM cameras. Delivering faithful, detailed images with rich tones these lenses also achieve sublime bokeh effects with a deep, emotive naturalism. Video performance is likewise exceptional with vivid footage that reaches beyond 4K. LUMIX S series, a third eye for the artist.

Adopting the Leica L-Mount* MOUNT

means compatibility with more products for greater equipment selection flexibility. LUMIX is developing L-Mount* compatible products together with Leica Camera and Sigma. The inner diameter of 51.6 mm achieves the perfect balance of compactness and image quality. The very short 20mm flange distance** allows a smaller lens construction with high image quality. Also, the 10-pin contacts provide scope for future functional improvements while hinting at exciting creative possibilities to come.

** Distance from front of mount to image sensor.

Allowing huge flexibility for equipment selection.

As part of the L-Mount* Alliance, LUMIX is developing L-Mount* compatible products with Leica Cameras and Sigma to offer a new world of possibilities and meeting a wider range of needs from the very start.

Two line-ups developed: S PRO lenses and S lenses

LUMIX S PRO Certified by LEICA

To satisfy even the most expressive photographer, exceptionally strict standards were applied to produce the LUMIX S PRO lens from start to finish – planning, design, development and production. Absolutely no compromise was made to total excellence in rendering, bokeh, or depth. The resulting high performance and superb quality pass every stringent evaluation standard used in a Leica lens.

LUMIX S

In addition to its high optical performance, the S LENS was developed by placing the emphasis on excellent mobility and usability. It features superb rendering performance, expanding the expressive world of S Series Full-frame Digital Single Lens Mirrorless Cameras.

S Pro lenses are manufactured using measurement instruments and quality assurance systems that have been certified by Leica Camera AG based on the company's quality standards.
* L-Mount is a trademark or registered trademark of Leica Camera AG.



LUMIX S Series Lens Roadmap

	16mm	24mm	35mm	50mm	70mm	85mm	105mm	200mm	280mm	400mm
				● LUMIX S PRO Certified by LEICA ● LUMIX S PRO 50mm F1.4						
		★ ● 24mm F1.8		★ ● 50mm F1.8		★ ● 85mm F1.8				
★	LARGE-APERTURE WIDE ZOOM									
		LUMIX S PRO Certified by LEICA LUMIX S PRO 24-70mm F2.8				LUMIX S PRO Certified by LEICA LUMIX S PRO 70-200mm F2.8 O.I.S.		280mm*	400mm**	
		LUMIX S PRO Certified by LEICA LUMIX S PRO 16-35mm F4								
		LUMIX S LUMIX S 24-105mm F4 MACRO O.I.S.								
		LUMIX S LUMIX S 20-60mm F3.5-5.6				LUMIX S PRO Certified by LEICA LUMIX S PRO 70-200mm F4 O.I.S.		280mm*	400mm**	
					★	TELEPHOTO ZOOM				

★ Scheduled for release during 2020-2021 (as of February 2020).

* When the teleconverter DMW-STC14 is attached. ** When the teleconverter DMW-STC20 is attached.



©Hideki Kono

1/200sec, F1.8, ISO 100

LUMIX S PRO Certified by LEICA



FIXED FOCAL LENGTH

LUMIX S PRO 50mm F1.4

(S-X50)



The Core of the LUMIX S series of Lenses, with a Large Aperture

The LUMIX S PRO 50mm F1.4 is a large-aperture fixed focal length lens with all the core elements of the LUMIX S series. With its versatile 50mm focal length, the wide F1.4 aperture achieves high resolution across the entire image while the lens construction delivers supreme optical performance surpassing even stringent LEICA standards. Delightfully smooth defocus gradation from the focus peak to neighboring image areas achieves beautiful bokeh effects, while suppressed focus breathing assures a rock-solid frame when rack focusing a video scene. Fast too, the double focus system's combined linear and stepping motor achieves sensor drive speeds up to 480 fps. With a refined design and superb operability this lens is built for high mobility. It is dust/splash-resistant* and able to withstand harsh conditions down to -10 degrees.

*Dust and splash resistance does not guarantee that damage will not occur if this lens is subjected to direct contact with dust and water.

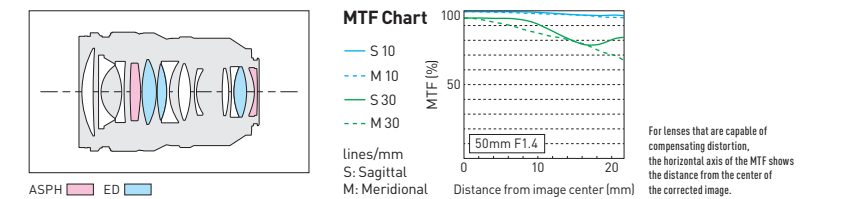

- Lens construction = 13 elements in 11 groups
- Closest focusing distance = 0.44 m/1.44 ft
- Maximum image magnification = Approx. 0.15x
- Filter size = 77 mm
- Dimensions = 90.0 [dia.] x Approx. 130 mm/3.54 [dia.] x 5.12 in
- Weight = Approx. 955 g/33.69 oz

•S PRO lenses are manufactured using measurement instruments and quality assurance systems that have been certified by Leica Camera AG based on the company's quality standards. •Leica is a registered trademark of Leica Microsystems IR GmbH.

LUMIX S PRO Certified by LEICA



WIDE ZOOM

LUMIX S PRO 16-35mm F4

[S-R1635]



An Ultra-Wide Zoom Combining Excellent Resolution and Beautiful Bokeh to All Four Corners

This lightweight and compact ultra-wide-angle zoom lens delivers superb resolution with a sense of three-dimensional depth throughout the zoom range as well as from image center to every corner. The bokeh effects are delightfully smooth while minimizing double-line bokeh and vignetting. High-speed AF control at 480-fps ensures faster communication between lens and camera body, resulting in improved AF accuracy and speed, while a focus clutch mechanism enables intuitive AF/MF switching for simple precision adjustments. Furthermore, by optimizing the optics within the barrel of the lens for high-resolution video and innovating the internal drive mechanism, the nuisance of focus breathing is now suppressed. This high-mobility lens is dust/splash-resistant* as well as being able to withstand severe temperatures down to -10 °C.

*Dust and splash resistance does not guarantee that damage will not occur if this lens is subjected to direct contact with dust and water.

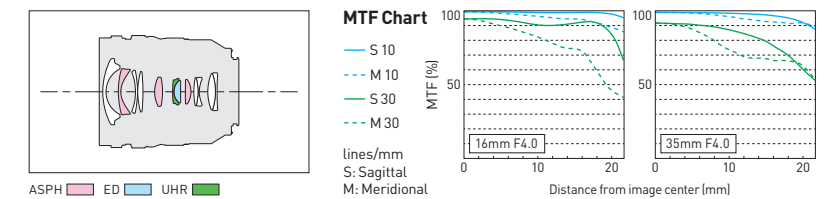

- Lens construction = 12 elements in 9 groups
- Closest focusing distance = 0.25 m/0.82 ft
- Maximum image magnification = Approx. 0.23x
- Filter size = 77 mm
- Dimensions = 85.0 [dia.] x Approx. 99.6 mm/3.92 in
- Weight = Approx. 500 g/17.63 oz

•S PRO lenses are manufactured using measurement instruments and quality assurance systems that have been certified by Leica Camera AG based on the company's quality standards. •Leica is a registered trademark of Leica Microsystems IR GmbH.



©Ben Grunow

1/50sec, F6.3, ISO 100



©Masumi Takahashi

1/30sec, F16, ISO 400



STANDARD ZOOM

LUMIX S PRO 24-70mm F2.8

[S-E2470]



F2.8 Aperture and Outstanding Expression throughout the Zoom Range with Pleasing Bokeh Effects

The LUMIX S PRO 24-70mm F2.8 is a large-aperture standard zoom lens delivering highly lifelike images and striking depth. It produces high resolution and high contrast across the entire focal range for landscapes, snapshots, portraits, and more. Indeed, optical performance exceeds even LEICA's professional standards and the lens construction effectively suppresses any chromatic aberration. Adoption of a focus clutch mechanism enables instant AF and MF switching to allow fine adjustments – simply slide the focus ring forward or backward. Soft and beautiful bokeh effects are achieved by smooth defocus gradation throughout the image, while suppressed focus breathing ensures smoother operation when shooting video. The AF sensor speed is fast too, at 480-fps, thanks to a double focus system.

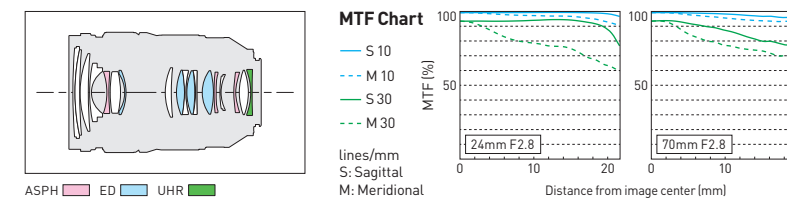

- Lens construction = 18 elements in 16 groups
- Closest focusing distance = 0.37 m/1.21 ft
- Maximum image magnification = Approx. 0.25x
- Filter size = 82 mm
- Dimensions = 90.9 [dia.] x Approx. 140 mm/3.58 [dia.] x 5.51 in
- Weight = Approx. 935 g/32.98 oz

* Dust and splash resistance does not guarantee that damage will not occur if this lens is subjected to direct contact with dust and water. •S PRO lenses are manufactured using measurement instruments and quality assurance systems that have been certified by Leica Camera AG based on the company's quality standards. •Leica is a registered trademark of Leica Microsystems IR GmbH.



©Olivier Anrigo

1/2500sec, F2.8, ISO 100



TELEPHOTO ZOOM

LUMIX S PRO 70-200mm F2.8 O.I.S.

[S-E70200]



Compatible with LUMIX S-Series teleconverters*. (sold separately) Teleconverters can extend up to 280mm [DMW-STC14, 1.4x] or 400mm [DMW-STC20, 2x]



A Large-Aperture Telephoto Zoom, Teleconverter-Extendable*, with Highly Descriptive Performance and F2.8 Brightness

This large-aperture telephoto zoom lens delivers F2.8 brightness across the entire 70-200mm range. With double-line bokeh and vignetting suppressed, as well as superb descriptive performance, bokeh effects are utterly sublime. The high-speed AF control (max. 480-fps) and double focus system [focus grouping divided into two], together achieve further AF speed and precision. For countering camera shake, Dual I.S.2 stabilization is also supported making it possible to use a 7-stop** slower shutter speed. Compatible with teleconverters, the lens also becomes a super telephoto capable of a maximum 400 mm focal length. The focus clutch mechanism offers instant AF/MF shifting and, with three separate focus buttons located around the barrel of the lens, precision focusing is effortlessly fast and smooth. This rugged lens is also dust/splash-resistant***, designed to tolerate temperatures as low as -10°C, for greater mobility and professional field shooting under challenging conditions.

* Use of the teleconverter reduces the effective aperture by one f/stop [DMW-STC14] or two f/stops [DMW-STC20]
 ** Based on the CIPA standard [Yaw/Pitch direction; focusing distance f=200mm] when LUMIX S1R/S1/S1H is used.
 *** Dust and splash resistance does not guarantee that damage will not occur if this lens is subjected to direct contact with dust and water.

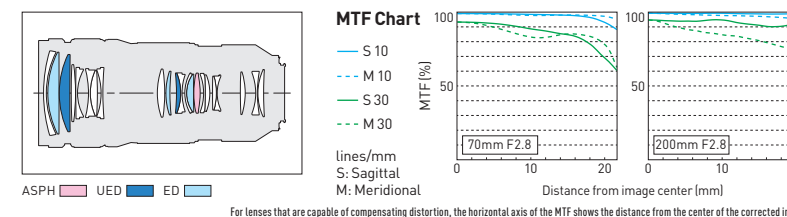

- Lens construction = 22 elements in 17 groups
- Filter size = 82 mm
- Closest focusing distance = 0.95 m/3.12 ft
- Dimensions = 94.4 [dia.] x Approx. 208.6 mm/3.71 [dia.] x 8.21 in
- Maximum image magnification = Approx. 0.21x
- Weight = Approx. 1570 g/55.38 oz

*S PRO lenses are manufactured using measurement instruments and quality assurance systems that have been certified by Leica Camera AG based on the company's quality standards. •Leica is a registered trademark of Leica Microsystems IR GmbH.



©Masaaki Aihara

1/2500sec, F18, ISO 320



TELEPHOTO ZOOM

LUMIX S PRO 70-200mm F4 O.I.S.

[S-R70200]



Compatible with LUMIX S-Series teleconverters*. (sold separately)
Teleconverters can extend up to 280mm (DMW-STC14, 1.4x) or 400mm (DMW-STC20, 2x)



A Telephoto Zoom, Teleconverter-Extendable*, with High Resolution and Stunning Clarity Across the Entire Zoom Range

This LUMIX S PRO 70-200mm F4 O.I.S. telephoto zoom lens provides high-resolution, high-contrast images across the entire zoom range, from portraits to sports. It is compatible with Panasonic's 5-axis Dual I.S.2 stabilization system, now being used with a full-frame mirrorless camera system for the first time. The lens features an Optical Image Stabilizer (O.I.S.) to compensate against camera-shake. This means you can shoot in low light or without a tripod, even at 200mm focal length. Designed for optimum lens alignment, bokeh effects are beautiful with minimal vignetting. The high-precision linear motor achieves sensor drive speeds up to 480-fps and suppressed focus breathing assures stable focus-racking for videos compared to lenses only designed for still photography.

* Use of the teleconverter reduces the effective aperture by one f/stop (DMW-STC14) or two f/stops (DMW-STC20)

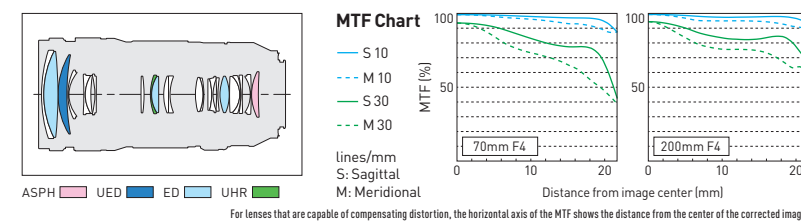

- Lens construction = 23 elements in 17 groups
- Closest focusing distance = 0.92 m/3.02 ft
- Maximum image magnification = Approx. 0.25x
- Filter size = 77 mm
- Dimensions = 84.4 [dia.] x Approx. 179 mm/3.32 [dia.] x 7.05 in
- Weight = Approx. 985 g/34.74 oz

* Dust and splash resistance does not guarantee that damage will not occur if this lens is subjected to direct contact with dust and water. •S PRO lenses are manufactured using measurement instruments and quality assurance systems that have been certified by Leica Camera AG based on the company's quality standards. •Leica is a registered trademark of Leica Microsystems IR GmbH.



©Jonas Borg

1/2000sec, F4.5, ISO 100



NEW

STANDARD ZOOM

LUMIX S 20-60mm F3.5-5.6

(S-R2060)



A Compact Standard Zoom, Perfect for Snaps Yet Expanding for Wide-Angle Scenes and Close-ups

At wide angle this lens makes it easy to shoot interiors where room space is limited. It also has stunning close-up capabilities for tabletop photography, as close as 0.15 m* (maximum magnification 0.43x). It also delivers smooth, high quality video recording thanks to a mechanism that suppresses focus breathing, a previously fatal problem in all interchangeable lenses designed for still image photography. Weighing a mere 350 g, the lens is also dust/splash-resistant**, with a front element fluorine coating that repels moisture and oil. It is designed to tolerate temperatures as low as -10°C, for greater mobility and professional field shooting under challenging conditions.

* At focal length 20-26mm
 ** Dust and splash resistance does not guarantee that damage will not occur if this lens is subjected to direct contact with dust and water.

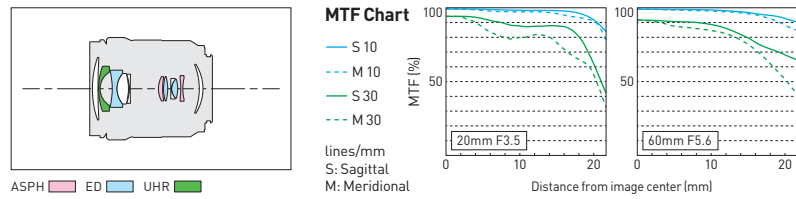

- Lens construction = 11 elements in 9 groups
- Closest focusing distance = 0.15 m/0.49 ft (Wide) / 0.4 m/1.31 ft (Tele)
- Maximum image magnification = Approx. 0.43x
- Filter size = 67 mm
- Dimensions = 77.4 [dia.] x Approx. 87.2 mm/3.05 [dia.] x 3.43 in
- Weight = Approx. 350 g/12.35 oz

• Leica is a registered trademark of Leica Microsystems IR GmbH.



©Annie Griffiths

1.6sec, F8, ISO 400



STANDARD ZOOM
**LUMIX S 24-105mm
 F4 MACRO 0.I.S.**

[S-R24105]



**Covering the Wide-Angle to Medium Telephoto Range
 with Macro Shot Capability**

The LUMIX S 24-105mm F4 MACRO 0.I.S. is a standard zoom covering wide-angle to medium-telephoto with high performance throughout. In addition, it has a 0.5x macro capability to 0.3 m focusing distance (min.). The lens works effectively with Panasonic's 5-axis Dual I.S. 2 technology, a stabilization system being used for the first time with a full-frame mirrorless camera system. The Optical Image Stabilizer (O.I.S.) in the lens effectively compensates against camera-shake so you can shoot in low light, or without a tripod, even in telephoto. The high-precision linear motor achieves sensor drive speeds up to 480-fps for super-fast AF, while suppressed focus breathing will be especially appreciated by video creators.

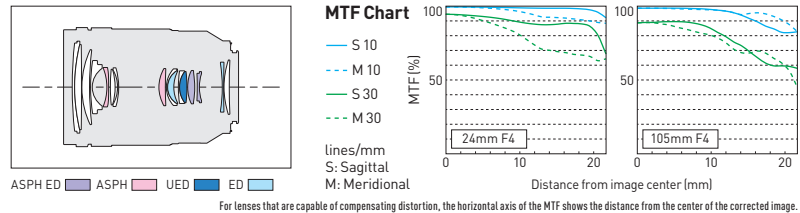

- Lens construction = 16 elements in 13 groups
- Closest focusing distance = 0.30 m/0.98 ft
- Maximum image magnification = Approx. 0.5x
- Filter size = 77 mm
- Dimensions = 84 [dia.] x Approx. 118 mm/3.31 [dia.] x 4.65 in
- Weight = Approx. 680 g/23.99 oz

* Dust and splash resistance does not guarantee that damage will not occur if this lens is subjected to direct contact with dust and water.
 • Leica is a registered trademark of Leica Microsystems IR GmbH.

LUMIX G series lens

The essence of aesthetics

Already pioneers in the field of digital single lens mirrorless cameras, LUMIX's Micro Four Thirds lenses are once again breaking new ground. Combining state-of-the-art digital technology with cutting-edge optics, the new lenses offer uncompromising quality, exceptional image rendering, and an agility able to capture the most fleeting of moments, all in an amazingly compact format. From wide-angle to telephoto, the extensive range delivers top-class performance, whether you are shooting stills or high-quality video. Most lenses are equipped with "MEGA O.I.S." or "POWER O.I.S." (Optical Image Stabilizer) for more efficient hand-held shooting with a telephoto or in low-light conditions. Without a doubt, this remarkable family of lenses will take your creativity to a new dimension.

A Breakthrough in Size and Weight: Mirrorless Configuration

LUMIX G's mirrorless configuration cuts the flange focal distance almost in half and reduces the body mount radius by 6 mm. With LUMIX G, you get a camera that is light in your hands, easy to maneuver, and a joy to use.

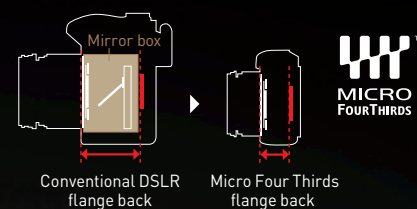

LUMIX G Series Lenses - Compact, Lightweight, Highly Mobile

The Micro Four Thirds standard brings greater simplicity to shooting stills or video. While LUMIX G series lenses may be smaller and weigh less, they still capture the same light intensity and image quality. Indeed, they completely redefine flexibility and allow you to choose a perfect lens to suit every scene. These are thrilling times to be a creator. Enjoy the whole world of professional photography and capture every moment with a Micro Four Thirds standard LUMIX G lens.



LEICA DG Lens LEICA DG LENS

A producer of precision instruments for more than a century, Leica was among the pioneers of still photography.

Today, Leica lenses have become a watchword for quality among professional photographers – a worldwide reputation gained thanks to the inventions and innovations Leica continues to develop across its product range.

The LEICA DG lenses, developed exclusively for the LUMIX G series and incorporating state-of-the-art optical and mechanical components, represent another innovative step forward.

These technological advances ensure gradations remain rich and sharp across the entire frame, thereby giving an exceptionally delicate and natural rendering of reality and outstanding expressive power.

The resulting images are so life-like, they look like you could reach out and feel the texture.

•Leica is a registered trademark of Leica Microsystems IR GmbH.



©Bence Máté

15 sec, F1.4, ISO 1250

This lens captures dynamic landscapes with rich perspective and high resolution. It also produces an impressive, natural defocusing effect with the F1.4 large aperture allowing handheld shots indoors in low lighting or outside at night.



FIXED FOCAL LENGTH

12mm F1.4 (35mm camera equivalent: 24mm)

LEICA F1.4 Large Aperture and Wide-Angle, Fixed Focal Length Lens – For Professional Nature Photographers Shooting Landscapes

This is one of the widest fixed focal length lenses in our Leica series. Five special internal lenses make it possible to clear the stringent Leica standard for exceptional image quality by suppressing flare and minimizing distortion all the way to the edge of the lens. With the camera's high-speed and high-precision AF with 240-fps capability, this lens becomes an ideal tool not only for photos but also for 4K video recordings where smooth, silent and precise focusing is essential. An AF/MF switch and an aperture ring in a durable metal structure, as well as a dust/splash-resistant* design, meet the needs of a wide range of photographic situations.

* Dust and splash resistance does not guarantee that damage will not occur if this lens is subjected to direct contact with dust and water.

LEICA DG SUMMILUX 12mm / F1.4 ASPH. (H-X012)

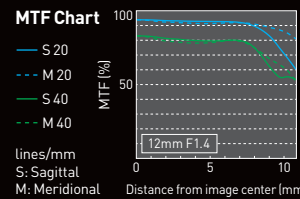
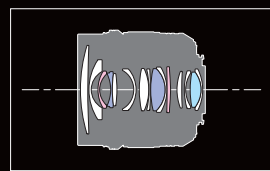

- Lens construction = 15 elements in 12 groups
- Closest focusing distance = 0.2 m/0.66 ft
- Maximum image magnification = Approx. 0.1x [35mm camera equivalent: 0.2x]
- Filter size = 62 mm
- Dimensions = 70.0 [dia.] x Approx. 70 mm/2.76 [dia.] x 2.76 in
- Weight = Approx. 335 g/11.82 oz

*LEICA is a registered trademark of Leica Microsystems IR GmbH. SUMMILUX is a registered trademark of Leica Camera AG. The LEICA DG lenses are manufactured using measurement instruments and quality assurance systems that have been certified by Leica Camera AG based on the company's quality standards.



1/5000 sec, F1.7, ISO 200

The LEICA DG SUMMILUX is ideal for everyday snapshots because its excellent mobility lets you carry the camera in a handbag with the lens mounted. It meets a wide range of shooting needs, such as wide-angle landscape shots and portraits with sharply focused subjects and beautifully defocused backgrounds.



FIXED FOCAL LENGTH

15mm F1.7 (35mm camera equivalent: 30mm)

Active Snapshot Shooting with a Compact, Lightweight, High-Quality F1.7 Lens

Naturally, this lens has passed Leica's stringent optical standards. The brightness of the F1.7 SUMMILUX enables photos with beautiful bokeh effects. The Iris Ring also lets you adjust exposure and depth of field, and the AF/MF Selector Switch makes it possible to change focus modes while aiming the camera. You get highly intuitive operation while looking through the viewfinder. This lens consists of 9 elements in 7 groups, including 3 aspherical lenses, for superbly high performance and a small size. It also offers knurled aluminum Iris/MF Rings, and various other luxurious, metallic fittings to make shooting a pleasure at all times.

LEICA DG SUMMILUX 15mm / F1.7 ASPH. (H-X015)

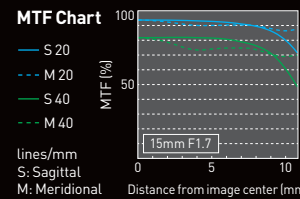
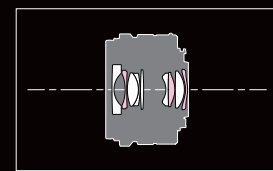

- Lens construction = 9 elements in 7 groups
- Closest focusing distance = 0.2 m/0.66 ft
- Maximum image magnification = Approx. 0.1x [35mm camera equivalent: 0.2x]
- Filter size = 46 mm
- Dimensions = 57.5 [dia.] x Approx. 36 mm/2.26 [dia.] x 1.42 in
- Weight = Approx. 115 g/4.06 oz

*LEICA is a registered trademark of Leica Microsystems IR GmbH. SUMMILUX is a registered trademark of Leica Camera AG. The LEICA DG lenses are manufactured using measurement instruments and quality assurance systems that have been certified by Leica Camera AG based on the company's quality standards.



©Mina Daimon

1/160 sec, F1.4, ISO 200

This large-aperture lens brings your creative vision to life at all times, in every location. It offers superb image quality with minimal distortion, even in low-light, while impressive bokeh effects turn ordinary scenes into stylish, evocative images.



FIXED FOCAL LENGTH

25mm F1.4 (35mm camera equivalent: 50mm)

This Rugged, Versatile, Go-anywhere 25mm F1.4 Lens is Perfect for every Shoot

As well as taking full advantage of the latest LUMIX G Series cameras, this lens delivers the exceptional image quality expected of Leica's stringent standards. The UHR index lens and glass mold aspherical lenses achieve uniformity and high descriptive performance from image center to the corners while Panasonic Nano Surface Coating minimizes ghosts and flaring. An inner focus drive and stepping motor ensure smooth, silent operation working with the camera's high-speed, high-precision contrast 240-fps AF system. Furthermore, boasting not only superior optics, this dust- and splash-resistant* lens is built to be compact, lightweight and rugged – ideal for studio, field and aerial work.

LEICA DG SUMMILUX 25mm / F1.4 II ASPH. (H-XA025)



*Dust and splash resistance does not guarantee that damage will not occur if this lens is subjected to direct contact with dust and water.

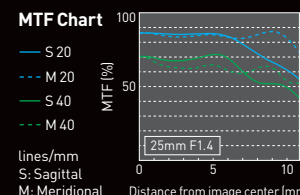
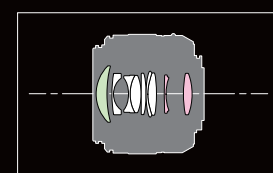

- Lens construction = 9 elements in 7 groups
- Closest focusing distance = 0.3 m/0.98 ft
- Maximum image magnification = Approx. 0.11x [35mm camera equivalent: 0.22x]
- Filter size = 46 mm
- Dimensions = 63 [dia.] x Approx. 54.5 mm/2.48 [dia.] x 2.14 in
- Weight = Approx. 205 g/7.23 oz

*LEICA is a registered trademark of Leica Microsystems IR GmbH. SUMMILUX is a registered trademark of Leica Camera AG. The LEICA DG lenses are manufactured using measurement instruments and quality assurance systems that have been certified by Leica Camera AG based on the company's quality standards.

ASPH UHR M: Meridional S: Sagittal Distance from image center (mm) For lenses that are capable of compensating distortion, the horizontal axis of the MTF shows the distance from the center of the corrected image.



©William Innes

1/200 sec, F2.8, ISO 1000

The LEICA DG NOCTICRON is an 85mm [35mm camera equivalent] medium-telephoto lens that uses a natural perspective to capture subjects in all their details. Stunningly beautiful shots are rendered for everything from portraits to theater stage performances and other relatively dark indoor scenes, and even nightscapes.

FIXED FOCAL LENGTH

42.5mm F1.2 (35mm camera equivalent: 85mm)

The Fully Open F1.2 NOCTICRON Speed Enables a Soft Defocused Background, a Hallmark of Leica, in this High-speed, Medium, Telephoto Lens

NOCTICRON speed is achieved by heeding to Leica's high optical standards. It consists of 14 lens elements in 11 groups, including 2 aspherical lenses, 1 ED lens, and 1 UHR lens. The lens barrel, aperture ring equipped, enables innate exposure correction. The 240-fps drive allows rapid, high-precision AF. A round, 9-blade iris yields richly defocused images, an exclusive 85mm [35mm equivalent] portrait feature. The lens hood, which curbs sun-caused ghosts and flaring, is crafted from joint-free aluminum, in par with the elegance of the Leica lens. The hood's hairline finish interior further reduces light reflection.

LEICA DG NOCTICRON 42.5mm / F1.2 ASPH. / POWER O.I.S. (H-NS043)



*Firmware must be updated to the latest version.

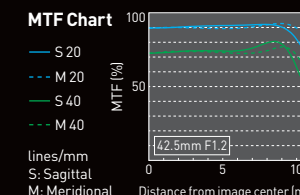
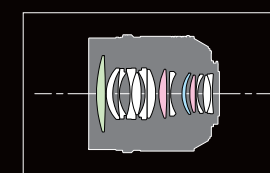

- Lens construction = 14 elements in 11 groups
- Closest focusing distance = 0.5 m/1.64 ft
- Maximum image magnification = Approx. 0.1x [35mm camera equivalent: 0.2x]
- Filter size = 67 mm
- Dimensions = 74 [dia.] x Approx. 76.8 mm/2.91 [dia.] x 3.02 in
- Weight = Approx. 425 g/15.04 oz

*LEICA is a registered trademark of Leica Microsystems IR GmbH. SUMMILUX is a registered trademark of Leica Camera AG. The LEICA DG lenses are manufactured using measurement instruments and quality assurance systems that have been certified by Leica Camera AG based on the company's quality standards.

ASPH UHR ED M: Meridional S: Sagittal Distance from image center (mm) For lenses that are capable of compensating distortion, the horizontal axis of the MTF shows the distance from the center of the corrected image.



1/200 sec, F2.8, ISO 200

This macro lens does much more than make small things bigger. As well as delivering beautiful defocused bokeh, it also lets you bring the entire frame – from corner to corner – into sharp focus. That gives you the freedom to create a wide variety of compositions, from portraits to telephoto shots to landscapes, making this lens a true all-round performer.



MACRO

45mm F2.8

(35mm camera equivalent: 90mm)

A Superior Macro Lens Brings Tiny Worlds into View

Created to meet Leica's stringent performance grade, this high-quality macro lens cuts distortion, ghosts, flaring and low peripheral resolution. With 14 elements in 10 groups, including one aspherical lens and one ED lens, it grants even contrast and high resolution all the way from 1:1 macro (35mm camera equivalent: 2x) to infinity. Utilizing an Inner Focus setup that shifts three groups of lenses, the elaborate focusing crucial to a macro lens has become both faster and quieter. Also featured is MEGA O.I.S., which fights hand-held blur, aids the capture of clear, sharp images, from macro and medium-telephoto portraits to wide landscapes and long telephoto shots.

LEICA DG MACRO-ELMARIT 45mm / F2.8 ASPH. / MEGA O.I.S. (H-ES045)



* Firmware must be updated to the latest version.

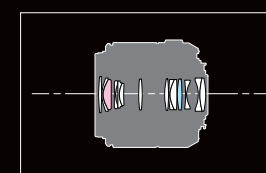

ASPH ED
M: Meridional S: Sagittal
For lenses that are capable of compensating distortion, the horizontal axis of the MTF shows the distance from the center of the corrected image.

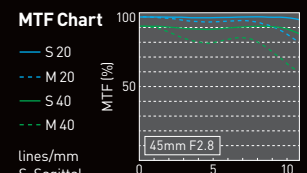

- Lens construction = 14 elements in 10 groups
- Closest focusing distance = 0.15 m/0.5 ft
- Maximum image magnification = Approx. 1.0x [35mm camera equivalent: 2.0x]
- Filter size = 46 mm
- Dimensions = 63 [dia.] x Approx. 62.5 mm/2.48 [dia.] x 2.46 in
- Weight = Approx. 225 g/7.94 oz

*LEICA is a registered trademark of Leica Microsystems IR GmbH. SUMMILUX is a registered trademark of Leica Camera AG. The LEICA DG lenses are manufactured using measurement instruments and quality assurance systems that have been certified by Leica Camera AG based on the company's quality standards.



©Bence Máté

1/640 sec, F2.8, ISO 800



Fitted with the bundled 1.4x teleconverter this ultra-telephoto extends to an astounding 560mm (35mm camera equivalent) for greater outdoors versatility when shooting wildlife or action sports.

- Teleconverter (when H-ES200 is attached):
- Focal length = 560mm [35mm camera equiv.]
 - Maximum aperture = F4.0
 - Minimum aperture = F22

FIXED FOCAL LENGTH

200mm F2.8

(35mm camera equivalent: 400mm)

Unprecedented Resolution even with Handheld Telephoto Shooting

With a fast F2.8 aperture, effective POWER O.I.S. compatible with 5-axis Dual I.S.2 stabilization, and robust design, this lens is built for professional use under harsh conditions. High resolution, high contrast images are achieved from corner to corner, while distortion and chromatic aberrations are suppressed by the inclusion of Ultra Extra-Low Dispersion (UED) lenses. A three magnets linear motor and 240-fps (max.) sensor drive enables a high-speed, high-precision contrast AF system, even in 4K video. Furthermore, the micro-step aperture drive helps adjust to brightness changes when panning.

* Dust and Splash Resistant does not guarantee that damage will not occur if this lens is subjected to direct contact with dust and water.

LEICA DG ELMARIT 200mm / F2.8 / POWER O.I.S. (H-ES200)

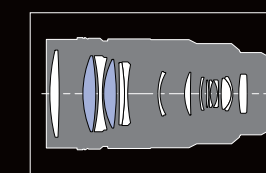

UED
M: Meridional S: Sagittal
For lenses that are capable of compensating distortion, the horizontal axis of the MTF shows the distance from the center of the corrected image.

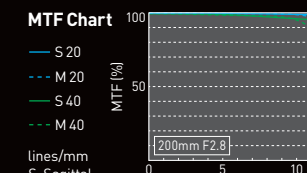

- Lens construction = 15 elements in 13 groups
- Closest focusing distance = 1.15 m/3.8 ft [Full], 3.0 m/9.8 ft [3m-Limit]
- Maximum image magnification = Approx. 0.2x [35 mm camera equivalent: 0.4x]
- Filter size = 77 mm
- Dimensions = 87.5 [dia.] x Approx. 174 mm/3.44 [dia.] x 6.85 in
- Weight = Approx. 1245 g/43.92 oz

*LEICA is a registered trademark of Leica Microsystems IR GmbH. SUMMILUX is a registered trademark of Leica Camera AG. The LEICA DG lenses are manufactured using measurement instruments and quality assurance systems that have been certified by Leica Camera AG based on the company's quality standards.



© Ken Duncan

1/20 sec, F7.1, ISO 200

From ultra-wide shots to the focal lengths you typically want for street snaps, this compact, lightweight lens supports filters and is easy to carry, easy to use and tough enough to take to the most challenging environments.



WIDE ZOOM

8-18mm F2.8-4.0 (35mm camera equivalent: 16-36mm)

Add Depth and Drama to Create Compelling Compositions

This compact wide-zoom is part of the new LEICA DG VARIO-ELMARIT F2.8-4.0 series. Spherical distortion and chromatic aberrations are effectively suppressed by the 15 lens element combination that features 1 aspherical ED lens, 3 aspherical lenses, 2 ED lenses and an UHR lens. As such, the lens achieves beautifully rendered high-quality images and the bright F2.8 aperture assures this quality even under low-light. It is also well suited to 4K video thanks to a silent inner focus drive system 240-fps and precision AF tracking. The design is dust/splash/freeze-resistant* so as to withstand the harshest environments.

* Dust and splash resistance does not guarantee that damage will not occur if this lens is subjected to direct contact with dust and water.

LEICA DG VARIO-ELMARIT 8-18mm / F2.8-4.0 ASPH. (H-E08018)

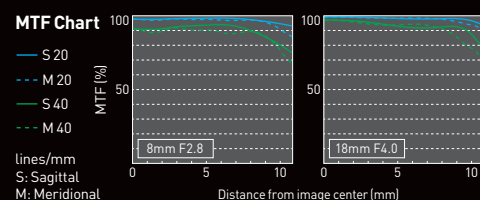
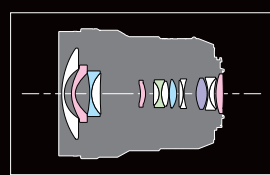

- Lens construction = 15 elements in 10 groups
- Closest focusing distance = 0.23 m / 0.75 ft
- Maximum image magnification = Approx. 0.12x [35 mm camera equivalent: 0.24x]
- Filter size = 67 mm
- Dimensions = 73.4 [dia.] x Approx. 88 mm / 2.89 [dia.] x 3.46 in
- Weight = Approx. 315 g / 11.1 oz

*LEICA is a registered trademark of Leica Microsystems IR GmbH. SUMMILUX is a registered trademark of Leica Camera AG. The LEICA DG lenses are manufactured using measurement instruments and quality assurance systems that have been certified by Leica Camera AG based on the company's quality standards.

ASPH/ED ASPH ED UHR M: Meridional
For lenses that are capable of compensating distortion, the horizontal axis of the MTF shows the distance from the center of the corrected image.



© Jonas Borg

1/8000 sec, F1.7, ISO 200

Featuring a focus clutch mechanism, for instant MF/AF switching, this is a versatile zoom lens for both stills and video. Shoot a dynamic landscape the one moment, an intimate portrait the next, even in low light.



AF

MF

STANDARD ZOOM

10-25mm F1.7 (35mm camera equivalent: 20-50mm)

World's First* Standard Zoom Lens Achieving Full-range F1.7, for Stills and Video

The standard zoom lens boasts a large aperture F1.7 across the entire zoom range of 20-50mm (35mm camera equivalent). Photographers gain a versatile companion of multiple focus options with astonishingly high resolution, as well as beautiful bokeh and high descriptive performance. Videographers appreciate the silent operation of a mechanism which also suppresses focus breathing while supporting high-speed, high-precision AF. In addition, the aperture smoothly catches up to any brightness change when zooming and panning. As well as the superior optics, the rugged dust/splash/freeze-resistant** design can withstand harsh conditions in the field.

* As a digital interchangeable lens for a mirrorless camera, as of May 31, 2019. ** Dust and splash resistance does not guarantee that damage will not occur if this lens is subjected to direct contact with dust and water.

LEICA DG VARIO-SUMMILUX 10-25mm / F1.7 ASPH. (H-X1025)

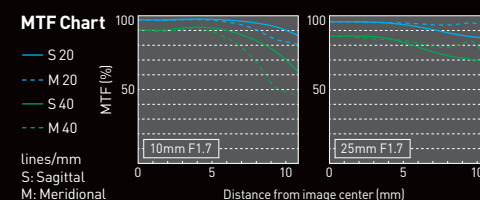
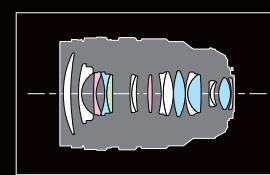

- Lens construction = 17 elements in 12 groups
- Closest focusing distance = 0.28 m / 0.92 ft
- Maximum image magnification = Approx. 0.14x [35 mm camera equivalent: 0.28x]
- Filter size = 77 mm
- Dimensions = 87.6 [dia.] x Approx. 128 mm / 3.45 [dia.] x 5.04 in
- Weight = Approx. 690 g / 24.34 oz.

*LEICA is a registered trademark of Leica Microsystems IR GmbH. SUMMILUX is a registered trademark of Leica Camera AG. The LEICA DG lenses are manufactured using measurement instruments and quality assurance systems that have been certified by Leica Camera AG based on the company's quality standards.

ASPH ED UHR M: Meridional
For lenses that are capable of compensating distortion, the horizontal axis of the MTF shows the distance from the center of the corrected image.



© Daimon Xanthopoulos

1/60 sec, F4.0, ISO 800

This light and easy to carry mid-length Leica zoom does the work of several essential lenses. It covers daily shots, from dynamic landscapes to portraits, even in low-light, and can withstand the harshest shoot conditions.



STANDARD ZOOM

12-60mm F2.8-4.0

(35mm camera equivalent: 24-120mm)

From Stunning Scenery to Striking Portraits, Zoom through a Suite of Standard Primes

This standard zoom is part of the new LEICA DG VARIO-ELMARIT F2.8-4.0 series. It boasts extraordinary range across ultra wide angle to super telephoto and the 9-blade aperture enhances subjects with stylish defocus backgrounds and natural effects. The combination of POWER O.I.S. stabilization with 5-axis Dual I.S.2 compatibility ensures blur-free results, even under lowlight conditions. In addition, excellent AF tracking and an inner focus drive assure precision performance and silent operation when shooting and zooming in 4K video. This versatile lens also has a rugged dust/splash/freeze-resistant* design.

* Dust and splash resistance does not guarantee that damage will not occur if this lens is subjected to direct contact with dust and water.

LEICA DG VARIO-ELMARIT 12-60mm / F2.8-4.0 ASPH. / POWER O.I.S. (H-ES12060)

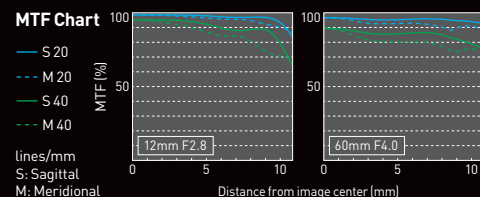
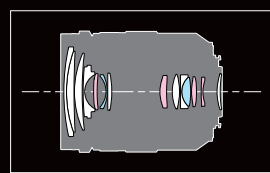

- Lens construction = 14 elements in 12 groups
- Closest focusing distance = 0.2 m / 0.66 ft (Wide), 0.24 m / 0.79 ft (Tele)
- Maximum image magnification = Approx. 0.3x [35mm camera equivalent: 0.6x]
- Filter size = 62 mm
- Dimensions = 68.4 [dia.] x Approx. 86 mm / 2.69 [dia.] x 3.39 in
- Weight = Approx. 320 g / 11.29 oz

*LEICA is a registered trademark of Leica Microsystems IR GmbH. SUMMILUX is a registered trademark of Leica Camera AG. The LEICA DG lenses are manufactured using measurement instruments and quality assurance systems that have been certified by Leica Camera AG based on the company's quality standards.

ASPH ED UED UHR
For lenses that are capable of compensating distortion, the horizontal axis of the MTF shows the distance from the center of the corrected image.



© Daimon Xanthopoulos

1/5000 sec, F6.3, ISO 200

Compatible with a 1.4x teleconverter (sold separately) this ultra-telephoto zoom extends to an astounding 560mm [35mm camera equivalent] for greater versatility outdoors when shooting wildlife or action sports.

• Maximum aperture = F4.0 • Minimum aperture = F22



TELEPHOTO ZOOM

50-200mm F2.8-4.0

(35mm camera equivalent: 100-400mm)

Covering Wide Angle to Ultra-Telephoto for High Quality Stills and Videos with Superb Mobility

A compact zoom covering focal length from mid-telephoto 100mm to ultra-telephoto 400mm [35mm camera equiv.]. Superior image quality based on strict LEICA quality standards. The lens system, with Nano Surface Coating, effectively suppresses spherical distortion or chromatic aberration to achieve high resolution and contrast from center to corners. Featuring POWER O.I.S. (Optical image stabilizer), the lens works with Dual I.S. and Dual I.S.2 image stabilizers when mounted to compatible LUMIX DSLM cameras, thereby effectively compensating for hand-shake movement. This is a flexible zoom for portraits, sports, wildlife and macro photography. It also boasts high-quality video recording capability and 4K video compatibility – with fast, accurate focusing and silent operation. It is built for professional use under hard conditions in a rugged dust/splash-resistant* design with freeze-resistance down to -10°C.

* Dust and splash resistance does not guarantee that damage will not occur if this lens is subjected to direct contact with dust and water.

LEICA DG VARIO-ELMARIT 50-200mm / F2.8-4.0 ASPH. / POWER O.I.S. (H-ES50200)

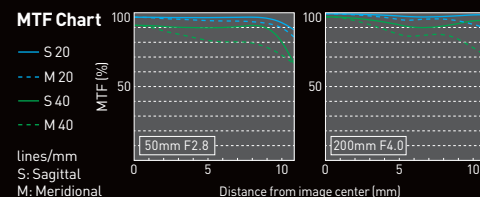
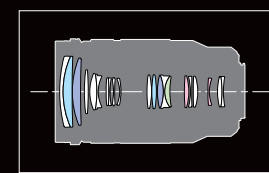

- Lens construction = 21 elements in 15 groups
- Closest focusing distance = 0.75 m / 2.46 ft
- Maximum image magnification = Approx. 0.25x [35 mm camera equivalent: 0.5x]
- Filter size = 67 mm
- Dimensions = 76 [dia.] x Approx. 132 mm / 2.99 [dia.] x 5.20 in
- Weight = Approx. 655 g / 23.10 oz

*LEICA is a registered trademark of Leica Microsystems IR GmbH. SUMMILUX is a registered trademark of Leica Camera AG. The LEICA DG lenses are manufactured using measurement instruments and quality assurance systems that have been certified by Leica Camera AG based on the company's quality standards.

ASPH ED UED UHR
For lenses that are capable of compensating distortion, the horizontal axis of the MTF shows the distance from the center of the corrected image.



©Bence Máté

1/500 sec, F6.3, ISO 400

Drawing subjects in from a distance, this ultra-telephoto zoom lens is ideal for capturing intense action sports or animals and birds you can't usually approach. Great for shooting distance stills or video requiring a compression effect. The unit also includes a rotating tripod mount for quick switching between landscape and portrait orientations. Macro function enables close-ups of plant life, etc., (max. 0.5x magnification [35mm camera equivalent]).



TELEPHOTO ZOOM

100-400mm F4.0-6.3 (35mm camera equivalent: 200-800mm)

Zooms up to 800mm* Yet Compact – An Ultra-Zoom Lens with LEICA Quality

Enjoy superb results in the medium telephoto range with this 200mm-800mm* ultra-zoom lens which achieves much-awaited reductions in weight and size. Thanks to POWER O.I.S. it also allows blur-free hand-held shots even at full zoom. With strong dust/splash-resistance** this is a reliable companion for outdoor photography and always delivers high-quality images in every situation. The unit comprises aspherical and Extra-Low Dispersion (ED) lenses (1 UED and 2 ED lenses) that clear the stringent optical standards of Leica. The Inner Focus linear motor drive enables high-speed and high precision AF with 240-fps capability. All in all, superior imaging performance with high resolution and high contrast throughout the entire zoom range.

*35mm camera equivalent. **Dust and splash resistance does not guarantee that damage will not occur if this lens is subjected to direct contact with dust and water. ***Firmware must be updated to the latest version.

LEICA DG VARIO-ELMAR 100-400mm / F4.0-6.3 ASPH. / POWER O.I.S. (H-RS100400)

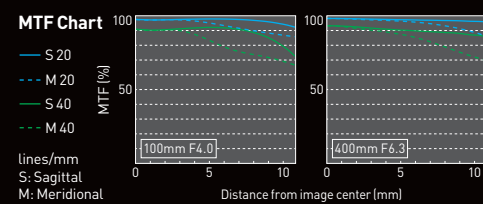
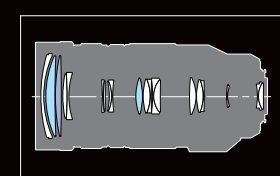

- Lens construction = 20 elements in 13 groups
- Closest focusing distance = 1.3 m/4.27 ft
- Maximum image magnification = Approx. 0.25x [35mm camera equivalent: 0.5x]
- Filter size = 72 mm
- Dimensions = 83 [dia.] x Approx. 171.5 mm/3.3 [dia.] x Approx. 6.75 in
- Weight = Approx. 985 g/34.74 oz

*LEICA is a registered trademark of Leica Microsystems IR GmbH. SUMMILUX is a registered trademark of Leica Camera AG. The LEICA DG lenses are manufactured using measurement instruments and quality assurance systems that have been certified by Leica Camera AG based on the company's quality standards.

LUMIX G Lens and X Lens

The G Lens and X Lens are the results of an uncompromising quest for the best-possible image quality.

As well as being compact, very light and exceptionally mobile, the precise and high-speed Contrast AF of the G Lens ensures outstanding image rendering performance.

The X Lens, while producing crisp textures and incredible transparency, delivers sharp, corner-to-corner contrast thanks to a special coating that minimizes ghosts and flaring.

These lenses cover a versatile range of focal lengths, from wide-angle to telephoto, for handling every shooting situation.



FISHEYE

8mm F3.5

(35mm camera equivalent: 16mm)

Fisheye Lens for Unique Images with Intriguing Deformation Effects

This fisheye lens with equisolid angle projection lets you create fascinating images with a 180° diagonal angle of view and intriguing deformation effects. Featuring 10 elements in 9 groups, including 1 ED lens, this lens system corrects chromatic aberration from magnification and other sources, to assure superb image rendering. The fisheye lens also features the Inner Focus system, as well as a virtually silent single-lens drive system that won't interfere with the sound you're recording when using the LUMIX G to shoot HD videos.



LUMIX G FISHEYE 8mm / F3.5 (H-F008)

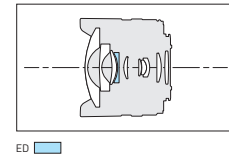

- Lens construction = 10 elements in 9 groups
- Closest focusing distance = 0.1 m/0.33 ft
- Maximum image magnification = Approx. 0.2x [35mm camera equivalent: 0.4x]
- Filter size = Front: Mounting not possible/ Rear: Sheet filter holder 22 mm x 22 mm
- Dimensions = 60.7 [dia.] x Approx. 51.7 mm/2.39 [dia.] x 2.04 in
- Weight = Approx. 165 g/5.82 oz



FIXED FOCAL LENGTH

14mm F2.5

(35mm camera equivalent: 28mm)

Fixed Focal Length Lens for Wide-Angle Shooting

A wide angle of view and outstanding depth of field make this pancake type wide-angle lens a good choice for both snapshots and landscapes. Rendering high-contrast images across the entire frame and correcting distortion, this super-thin lens is especially ideal for capturing subjects that are primarily linear, such as buildings with a number of straight lines. Its simple lens construction – 6 elements in 5 groups, including 3 glass aspherical lenses – allows both high performance and an astonishingly compact size.



LUMIX G 14mm / F2.5 II ASPH. (H-H014A)

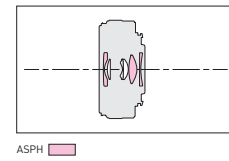

- Lens construction = 6 elements in 5 groups
- Closest focusing distance = 0.18 m/0.59 ft
- Maximum image magnification = Approx. 0.1x [35mm camera equivalent: 0.2x]
- Filter size = 46 mm
- Dimensions = 55.5 [dia.] x Approx. 20.5 mm/2.19 [dia.] x 0.81 in
- Weight = Approx. 55 g/1.94 oz



FIXED FOCAL LENGTH

20mm / 25mm F1.7

(35mm camera equivalent: 40mm / 50mm)

A Bright F1.7 Aperture Lens – For Casual Snapshots or Artistic Portraits

A high-speed F1.7 aperture defines this fixed focal length lens, delivering images with a delicate bokeh effect and high contrast. Even under dim lighting you can shoot at a high shutter speed – no need to increase ISO sensitivity – and still capture beautifully expressive images with minimal noise. The aspherical lenses within are optimally configured to deliver consistently sharp images from corner to corner – achieving enhanced performance in a compact system. Always at your side, it is ready to artistically render everyday scenes and beautiful portraits.



LUMIX G 20mm / F1.7 II ASPH. (H-H020A)

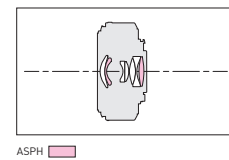

- Lens construction = 7 elements in 5 groups
- Closest focusing distance = 0.2 m/0.66 ft
- Maximum image magnification = Approx. 0.13x [35mm camera equivalent: 0.25x]
- Filter size = 46 mm
- Dimensions = 63 [dia.] x Approx. 25.5 mm / 2.48 [dia.] x 1.00 in
- Weight = Approx. 87 g/3.07 oz



LUMIX G 25mm / F1.7 ASPH. (H-H025)

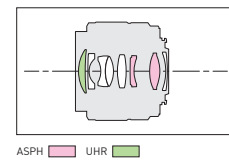

- Lens construction = 8 elements in 7 groups
- Closest focusing distance = 0.25 m/0.82 ft
- Maximum image magnification = Approx. 0.14x [35mm camera equivalent: 0.28x]
- Filter size = 46 mm
- Dimensions = 60.8 [dia.] x Approx. 52 mm / 2.4 [dia.] x 2.05 in
- Weight = Approx. 125 g/4.41 oz



LUMIX G FISHEYE 8mm / F3.5, 1/400 sec, F8.0, ISO 100



LUMIX G 25mm / F1.7 ASPH., 1/600 sec, F1.7, ISO 200

MACRO

30mm F2.8

(35mm camera equivalent: 60mm)

Multifunctional Lens – From Macros to Portraits

With 9 elements in 9 groups, including one aspherical lens, this lens delivers high performance in a compact size. Its Inner Focus system provides high resolution and contrast across the entire focusing range, from 1:1 macro to infinity. A stepping motor drives the lens for 240-fps AF. You get quick, smooth, and quiet focusing for both still and video images. When shooting portraits and other subjects with a shallow depth of field, the 7-blade circular aperture renders stunning bokeh effects. Multi-coating minimizes ghosts and flaring to produce rich expressiveness with crisp clarity and beautiful depth from corner to corner. This lens gives you the images that you envision.



LUMIX G MACRO 30mm / F2.8 ASPH. / MEGA O.I.S. (H-H5030)



* Firmware must be updated to the latest version.

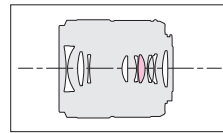

ASPH

- Lens construction = 9 elements in 9 groups
- Closest focusing distance = 0.105 m/0.345 ft
- Maximum image magnification = Approx. 1.0x (35mm camera equivalent: 2.0x)
- Filter size = 46 mm
- Dimensions = 58.8 [dia.] x Approx. 63.5 mm / 2.3 [dia.] x 2.5 in
- Weight = Approx. 180 g/6.35 oz

FIXED FOCAL LENGTH

42.5mm F1.7

(35mm camera equivalent: 85mm)

Stunning Bokeh Effects from a Bright F1.7 Medium Telephoto Lens

This new lens system features 10 elements in 8 groups, including one aspherical lens, to minimize aberration and distortion. Its 7-blade circular aperture produces stunning bokeh effects. Multi-coating reduces ghosts and flaring to render images with crisp clarity and beautiful depth from corner to corner. POWER O.I.S. effectively suppresses hand-shake. You get sharp, clear images even in nightscapes and indoor shots. The Inner Focus system provides high resolution across the entire focusing range. And a new stepping motor drives the lens at 240-fps, for smooth, vibration-free focusing of both still and video images.



LUMIX G 42.5mm / F1.7 ASPH. / POWER O.I.S. (H-H5043)



* Firmware must be updated to the latest version.

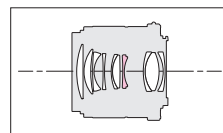

ASPH

- Lens construction = 10 elements in 8 groups
- Closest focusing distance = 0.31 m/1.02 ft
- Maximum image magnification = Approx. 0.2x (35mm camera equivalent: 0.4x)
- Filter size = 37 mm
- Dimensions = 55 [dia.] x Approx. 50 mm / 2.2 [dia.] x 1.97 in
- Weight = Approx. 130 g/4.59 oz

WIDE ZOOM

7-14mm F4.0

(35mm camera equivalent: 14-28mm)

A Super-Small, Lightweight, Ultra-Wide-Angle Zoom Lens

This lens – the world’s smallest of its kind* – gives you an extraordinary perspective with its 114° diagonal angle of view. Small and light enough to take anywhere you go, this ultra-wide-angle lens lets you capture the vastness and majesty of sweeping landscapes with true-to-life ambience and perspective while traveling. In addition to two aspherical lenses for correcting a variety of aberrations, the lens is generously equipped with four Extra-Low Dispersion (ED) lenses to eliminate chromatic aberration from magnification. It renders sharp, crisp images across the entire zoom range. * As of March 25, 2009, for wide-angle zoom lenses for digital SLR cameras



LUMIX G VARIO 7-14mm / F4.0 ASPH. (H-F007014)

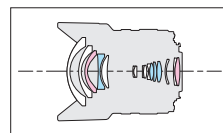

ASPH ED

- Lens construction = 16 elements in 12 groups
- Closest focusing distance = 0.25 m/0.8 ft
- Maximum image magnification = Approx. 0.08x (35mm camera equivalent: 0.15x)
- Dimensions = 75 [dia.] x Approx. 83.1 mm/2.95 [dia.] x 3.27 in
- Weight = Approx. 300 g/10.58 oz



LUMIX G 42.5mm / F1.7 ASPH. / POWER O.I.S., 1/800 sec, F1.7, ISO 200



LUMIX G VARIO 7-14mm / F4.0 ASPH., 1/200 sec, F8.0, ISO 100

STANDARD ZOOM

12-32mm F3.5-5.6 / 12-35mm F2.8

(35mm camera equivalent: 24-64mm/24-70mm)

A Standard Zoom Lens with Full-Range, High Performance and Excellent Portability

This nimble, lightweight, compact zoom covers an impressive range of scenic possibilities – from wide-angle 24mm to 64mm/70mm (35mm camera equivalent). Ideal for portraits or capturing landscapes and snapshots. With a 2-stage retractable mechanism the 12-32mm zoom is as easy to carry as a pancake lens and the 12-35mm is compatible with 5-axis Dual I.S.2 – advanced stabilization synchronized in both lens and camera. So, while making full-use of the wide aperture, you can take shake-free pictures in low-light without flash. A dust/splash/freeze-resistant* design ensures reliable outdoor use. *Dust and splash resistance does not guarantee that damage will not occur if this lens is subjected to direct contact with dust and water.



LUMIX G VARIO 12-32mm / F3.5-5.6 ASPH. / MEGA O.I.S.
[H-FS12032]

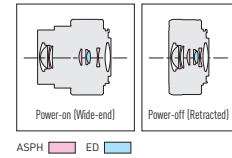

- Lens construction = 8 elements in 7 groups
- Closest focusing distance = 0.2 m/0.66 ft (Wide), 0.3 m/0.98 ft (Tele)
- Maximum image magnification = Approx. 0.13x [35mm camera equivalent: 0.26x]
- Filter size = 37 mm
- Dimensions = 55.5 [dia.] x Approx. 24 mm/2.2 [dia.] x 0.94 in
- Weight = Approx. 70 g/2.47 oz



LUMIX G X VARIO 12-35mm / F2.8 II ASPH. / POWER O.I.S.
[H-HSA12035]

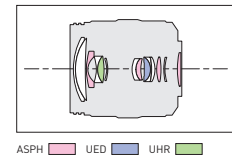

- Lens construction = 14 elements in 9 groups
- Closest focusing distance = 0.25 m/0.82 ft
- Maximum image magnification = Approx. 0.17x [35mm camera equivalent: 0.34x]
- Filter size = 58 mm
- Dimensions = 67.6 [dia.] x Approx. 73.8 mm/2.66 [dia.] x 2.91 in
- Weight = Approx. 305 g/10.76 oz

STANDARD ZOOM

12-60mm F3.5-5.6

(35mm camera equivalent: 24-120mm)

A 5x Zoom that Takes You to the Next Level

This 5x optical standard zoom lens effortlessly slides from 24mm wide-angle through to 120mm (35mm camera equivalent) medium telephoto. High performance is delivered by 11 elements in 9 groups with 3 aspherical lenses and 1 Extra-Low Dispersion (ED) lens. These deliver consistent image quality throughout the entire zoom range. The Inner Focus drive provides light-speed auto focusing, with a smooth and silent mechanism that improves severe focus situations, 4K video shooting in particular. Other features include POWER O.I.S. and Dual I.S. compatibility. Built also with a dust/splash-resistant* design for confident outdoors shooting, this is a lens to comfortably cover any occasion you attend or chance upon. *Dust and splash resistance does not guarantee that damage will not occur if this lens is subjected to direct contact with dust and water.



LUMIX G VARIO 12-60mm / F3.5-5.6 ASPH. / POWER O.I.S.
[H-FS12060]

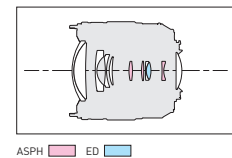

- Lens construction = 11 elements in 9 groups
- Closest focusing distance = 0.2 m/0.66 ft (Wide), 0.25 m/0.82 ft (Tele)
- Maximum image magnification = Approx. 0.27x [35mm camera equivalent: 0.54x]
- Filter size = 58 mm
- Dimensions = 66 [dia.] x Approx. 71 mm/2.6 [dia.] x 2.80 in
- Weight = Approx. 210 g/7.41 oz



LUMIX G X VARIO 12-35mm / F2.8 II ASPH. / POWER O.I.S., 1/125 sec, F8.0, ISO 200



LUMIX G VARIO 12-60mm / F3.5-5.6 ASPH. / POWER O.I.S., 1/400 sec, F14.0, ISO 200

STANDARD ZOOM

14-42mm / 14-45mm F3.5-5.6

(35mm camera equivalent: 28-84mm/28-90mm)

A Standard Zoom to Perfectly Capture Everyday Moments and Travel Memories

This lens has a wide focal length range up to 3x zoom (approx.) – or 3.2x with the 14-45mm option. As such it suits multiple situations from landscapes to travel snapshots. The G X VARIO PZ 14-42mm has an ultra-compact retractable design and boasts superior POWER O.I.S. stabilization with a silent zoom for clean audio when shooting video. The two aspherical lenses of the G VARIO 14-42mm make it small and lightweight while the G VARIO 14-45mm has 12 lens elements in 9 groups, incl. a glass-molded aspherical lens, correcting for aberrations to deliver superb optical performance.



LUMIX G X VARIO PZ 14-42mm / F3.5-5.6 ASPH. / POWER O.I.S. X

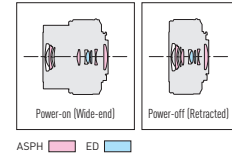

- Lens construction = 9 elements in 8 groups
- Closest focusing distance = 0.2 m/0.66 ft [Wide], 0.3 m/0.98 ft [Tele]
- Maximum image magnification = Approx. 0.17x [35mm camera equivalent: 0.34x]
- Filter size = 37 mm
- Dimensions = 61 [dia.] x Approx. 26.8 mm / 2.4 [dia.] x 1.1 in (When the lens is retracted)
- Weight = Approx. 95 g/3.4 oz



LUMIX G VARIO 14-42mm / F3.5-5.6 II ASPH. / MEGA O.I.S.

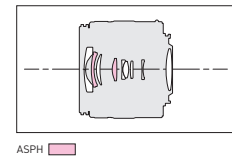

- Lens construction = 9 elements in 8 groups
- Closest focusing distance = 0.2 m/0.66 ft [Wide], 0.3 m/0.98 ft [Tele]
- Maximum image magnification = Approx. 0.17x [35mm camera equivalent: 0.34x]
- Filter size = 46 mm
- Dimensions = 56 [dia.] x Approx. 49 mm/2.2 [dia.] x 1.9 in
- Weight = Approx. 110 g/3.88 oz



LUMIX G VARIO 14-45mm / F3.5-5.6 ASPH. / MEGA O.I.S.

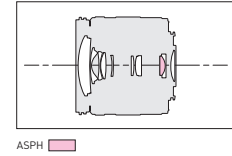

- Lens construction = 12 elements in 9 groups
- Closest focusing distance = 0.3 m/0.98 ft
- Maximum image magnification = Approx. 0.17x [35mm camera equivalent: 0.34x]
- Filter size = 52 mm
- Dimensions = 60 [dia.] x Approx. 60 mm/2.36 [dia.] x 2.36 in
- Weight = Approx. 195 g/6.88 oz

TELEPHOTO ZOOM

14-140mm F3.5-5.6

(35mm camera equivalent: 28-280mm)

A 10x Optical Zoom Lens with a Compact, Lightweight, Elegant Design

This 10x optical zoom lens is lightweight (approximately 265 g) and features an elegant, dust/splash-resistant* design in a compact size of total length 75mm. Focal length covers the range from 28mm to 280mm (both 35mm camera equivalent) which provides high image quality throughout thanks to 2 ED lenses and 3 aspherical lenses. It also enables close-up shooting (down to 30 cm) at wide-angle, and macro shots (max. shooting magnification of 0.25x) at telephoto. A newly developed stepping motor delivers high-speed AF with 240-fps lens drive. This high-speed, high-precision zoom lens also handles HD video shooting. *Dust and splash resistance does not guarantee that damage will not occur if this lens is subjected to direct contact with dust and water.



LUMIX G VARIO 14-140mm / F3.5-5.6 II ASPH. / POWER O.I.S.

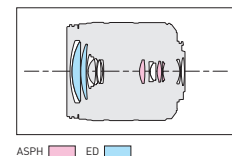

- Lens construction = 14 elements in 12 groups
- Closest focusing distance = 0.3 m/0.98 ft [Wide], 0.5 m / 1.64 ft [Tele]
- Maximum image magnification = Approx. 0.25x [35mm camera equivalent: 0.5x]
- Filter size = 58 mm
- Dimensions = 67 [dia.] x Approx. 75 mm/2.64 [dia.] x 2.95 in
- Weight = Approx. 265 g/9.35 oz



LUMIX G X VARIO PZ 14-42mm / F3.5-5.6 ASPH. / POWER O.I.S., 1/2000 sec, F7.1, ISO 160



LUMIX G VARIO 14-140mm / F3.5-5.6 II ASPH. / POWER O.I.S., 1/60 sec, F7.1, ISO 160



©Bence Máté

LUMIX G X VARIO 35-100mm / F2.8 II / POWER O.I.S., 1/500 sec, F2.8, ISO 640

TELEPHOTO ZOOM

35-100mm F2.8/F4.0-5.6

(35mm camera equivalent: 70-200mm)

A High-Performance Telephoto Zoom – Easy to Carry, Great for Stylish Effects

This lens covers the 70-200mm range (35mm camera equivalent), in a compact size and lightweight for easy portability bringing exquisite bokeh expression to both telephoto and portrait shots. With the dust/splash/freeze-resistant* design of the high-speed F2.8 X Lens you can take it almost anywhere, using high shutter speeds to capture even fast-moving subjects without worrying about shooting circumstances. The lens is compatible with 5-axis Dual I.S.2 stabilization which works with in-camera shake compensation so that, even for hand-held shots in low light you secure blur-free images. * Dust and splash resistance does not guarantee that damage will not occur if this lens is subjected to direct contact with dust and water.



LUMIX G X VARIO 35-100mm / F2.8 II / POWER O.I.S. X

(H-H5A35100)

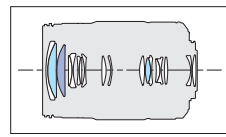

- Lens construction = 18 elements in 13 groups
- Closest focusing distance = 0.85 m/2.8 ft
- Maximum image magnification = Approx. 0.1x [35mm camera equivalent: 0.2x]
- Filter size = 58 mm
- Dimensions = 67.4 [dia.] x Approx. 99.9 mm/2.65 [dia.] x 3.93 in
- Weight = Approx. 357 g/12.59 oz

ED UED



LUMIX G VARIO 35-100mm / F4.0-5.6 ASPH. / MEGA O.I.S.

(H-FS35100)

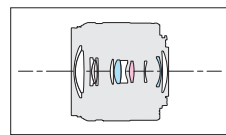

- Lens construction = 12 elements in 9 groups
- Closest focusing distance = 0.9 m/3.0 ft
- Maximum image magnification = Approx. 0.11x [35mm camera equivalent: 0.22x]
- Filter size = 46 mm
- Dimensions = 55.5 [dia.] x Approx. 50 mm/2.2 [dia.] x 1.97 in
- Weight = Approx. 135 g/4.76 oz

ASPH ED

TELEPHOTO ZOOM

45-150mm / -175mm / -200mm F4.0-5.6

(35mm camera equivalent: 90-300mm / 90-350mm / 90-400mm)

Zooming from Medium through Standard, All the Way to Super Telephoto

This is a lens for dynamic action shots at soccer matches or wildlife in the field. The 45-200mm is a super telephoto, zooming as close as 400mm (35mm camera equivalent) and achieving high speed, high precision AF with 240-fps drive compatibility. It also works for 5-axis Dual I.S.2 stability together with in-camera shake correction while the dust/splash-resistant* design lets you use it anywhere. The 45-150mm has an Inner Focus system for high-speed Contrast AF and the 45-175mm is easy to use thanks to a silent power zoom which moves while actual lens-length stays fixed. * Dust and splash resistance does not guarantee that damage will not occur if this lens is subjected to direct contact with dust and water.



LUMIX G VARIO 45-150mm / F4.0-5.6 ASPH. / MEGA O.I.S.

(H-FS45150)



* Firmware must be updated to the latest version.

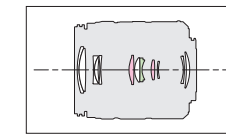

ASPH UHR

- Lens construction = 12 elements in 9 groups
- Closest focusing distance = 0.9 m/3.0 ft
- Maximum image magnification = Approx. 0.17x [35mm camera equivalent: 0.35x]
- Filter size = 52 mm
- Dimensions = 62 [dia.] x Approx. 73 mm/2.4 [dia.] x 2.9 in
- Weight = Approx. 200 g/7.1 oz



LUMIX G X VARIO PZ 45-175mm / F4.0-5.6 ASPH. / POWER O.I.S. X

(H-PS45175)



* Firmware must be updated to the latest version.

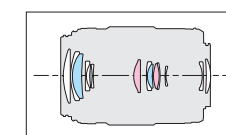

ASPH ED

- Lens construction = 14 elements in 10 groups
- Closest focusing distance = 0.9 m/3.0 ft
- Maximum image magnification = Approx. 0.2x [35mm camera equivalent: 0.4x]
- Filter size = 46 mm
- Dimensions = 61.6 [dia.] x Approx. 90.0 mm/2.4 [dia.] x 3.5 in
- Weight = Approx. 210 g/7.4 oz



LUMIX G VARIO 45-200mm / F4.0-5.6 II / POWER O.I.S.

(H-FSA45200)

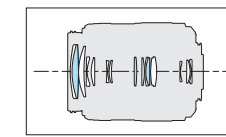

ED

- Lens construction = 14 elements in 13 groups
- Closest focusing distance = 1.0 m/3.28 ft
- Maximum image magnification = Approx. 0.19x [35mm camera equivalent: 0.38x]
- Filter size = 52 mm
- Dimensions = 70 [dia.] x Approx. 100 mm/2.76 [dia.] x 3.94 in
- Weight = Approx. 370 g/13.05 oz

TELEPHOTO ZOOM

100-300mm F4.0-5.6

(35mm camera equivalent: 200-600mm)

A 5-axis Dual I.S.2 Compatible Lens for Shake-free Ultra-Telephoto Shooting

As well as correcting camera shake with POWER O.I.S. this lens is compatible with 5-axis Dual I.S.2 stabilization, working together with in-camera shake suppression (B.I.S) so you can take blur-free handheld shots even at super telephoto range. An ED lens mounted in the first lens group corrects the color bleed aberrations from zooming and an Inner Focus system enhances focusing to enable high-speed Contrast AF with 240-fps drive compatibility. The lens is also compact and lightweight to carry anywhere and, thanks to a dust/splash-resistant* design, is well-suited to field use. * Dust and splash resistance does not guarantee that damage will not occur if this lens is subjected to direct contact with dust and water.



LUMIX G VARIO 100-300mm / F4.0-5.6 II / POWER O.I.S.

(H-FSA100300)

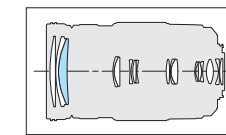

ED

- Lens construction = 17 elements in 12 groups
- Closest focusing distance = 1.5 m/4.92 ft
- Maximum image magnification = Approx. 0.21x [35mm camera equivalent: 0.42x]
- Filter size = 67 mm
- Dimensions = 73.6 [dia.] x Approx. 126 mm/2.90 [dia.] x 4.96 in
- Weight = Approx. 520 g/18.34 oz

Lens Technology

These cutting-edge technologies support the compact size, light weight, and high-quality images of LUMIX lenses.

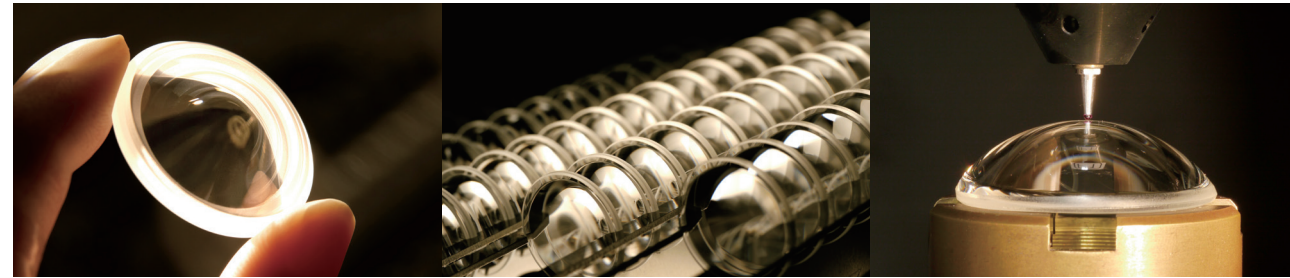

Lenses Manufactured with Uncompromising Devotion to High Image Quality

At the Yamagata Plant, lenses are processed, assembled, inspected, and individually packaged, all in a Clean Room environment. This stringent level of quality control is unique to LUMIX lenses. For example, to inspect aspherical lenses, we use an instrument called the UA3P Ultra-Accurate 3D Profilometer, which was originally developed by Panasonic and now plays an essential role in the development and manufacturing activities of many optical device manufacturers. Using this instrument, with its measurement accuracy of 1/10,000 mm, we conduct objective, numerical evaluations. These criteria are then used to determine the presence of ghosts and flaring, the color of coatings, and the degree of defocus, in addition to checking the operating feel of the focus ring and aperture ring, and the sound quality of various motors, in order to ensure high-quality production control. As a result, the quality of Panasonic lenses has gained high worldwide acclaim for accuracy and image quality.

Aspherical Lenses*

LUMIX lenses feature a number of aspherical lenses that achieve high image quality and compactness, as well as effectively preventing spherical and distortion aberrations. Each one has the effect of several spherical lenses, thereby making a smaller overall size and weight possible. However, because such lenses demand high dimensional accuracy, this usually limits lens shapes and materials. So, our Yamagata Plant began developing cutting-edge technologies for molded lenses from the outset. Today, in addition to ordinary glass materials, the plant produces technically challenging ED materials. In order to further enhance defocusing – one of the most attractive features of interchangeable lenses – the Yamagata Plant has developed new molding technology to dramatically reduce the problematic ‘onion-ring bokeh’ concentric rings that usually result from the precision glass molding of aspherical lenses. Now, the ‘onion-ring’ aberrations are minimal. With the wider usage of aspherical lenses with outstanding image rendering capabilities, this advance makes defocused bokeh effects even more beautiful.

*Aspherical lenses are not used in some lens units.

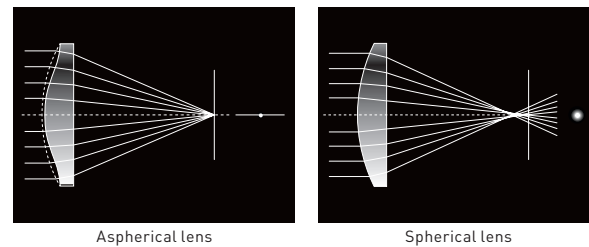

Aspherical ED Lenses

These lenses are made with ED materials that correct for chromatic, spherical and other aberrations. The resulting high image quality also benefits from the combined features of a small number of aspherical and ED lenses. Fewer also means reduced size and weight. Ultimately, the lenses gain improved focus accuracy and better image stability.

Ultra-High Refractive Index (UHR) Lens

The use of the newly developed ultra-high refractive index (UHR) lens has improved optical performance, reduced size and weight, and achieved uniform image quality from the center to the edges of the image.

Ultra Extra-Low Dispersion (UED) Lenses

In a conventional lens made only of optical glass, correcting chromatic aberration becomes difficult when the focal length is long or angle of view wide, an inadequacy resulting in contrast degradation or color bleeding. Panasonic’s Ultra Extra-Low Dispersion (UED/ED) lens suppresses the prism’s color separation effect to correct longitudinal chromatic aberration at the telephoto zoom setting and chromatic differences of magnification at the wide-angle setting to render sharp, high-contrast images with clear colors from corner to corner.

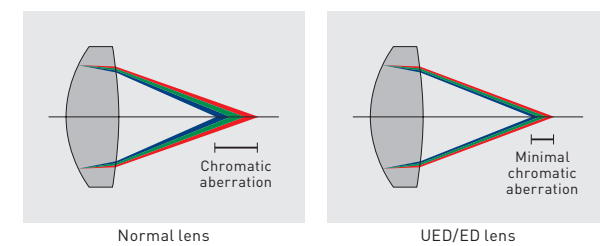

Multicoating Process

Utmost caution is exercised in coating the LUMIX series lenses to suppress ghosts and flaring, increase durability, and enhance image beauty while ensuring optimum color balance. In addition to finely regulating the reflectance for the main wavelengths, LUMIX G series lenses feature a coating that reduces the reflectance of light that enters at an angle. This multicoating process is widely used on lenses with a small radius of curvature, such as those in ultra-wide-angle lenses and fisheye lenses. It greatly improves the image rendering performance when shooting against a light source. Moreover, the bonded surfaces of cemented lenses are also given an original multicoating process to further reduce reflection. This results in high-quality images with superb clarity.

*Aspherical lenses are not used in some lens units.

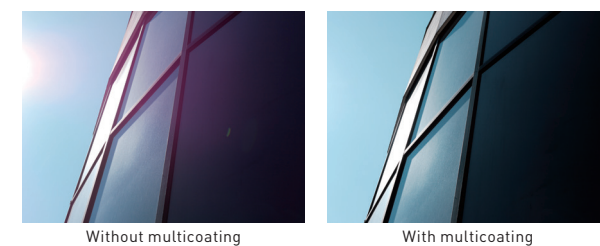

Nano Surface Coating



Anti-reflection to an unprecedented degree has been made possible by Panasonic’s original Nano Surface Coating technology. By forming a thin film with an ultra-fine nano-level structure and a super-low refractive index on the lens surface, Panasonic has achieved a dramatic reduction in the amounts of light reflection over the entire visible light range (from 380 to 780 nm). This significantly decreases ghosts and flaring and renders pure and clear images. This advanced coating technology is highly acclaimed by the camera and lens industries.

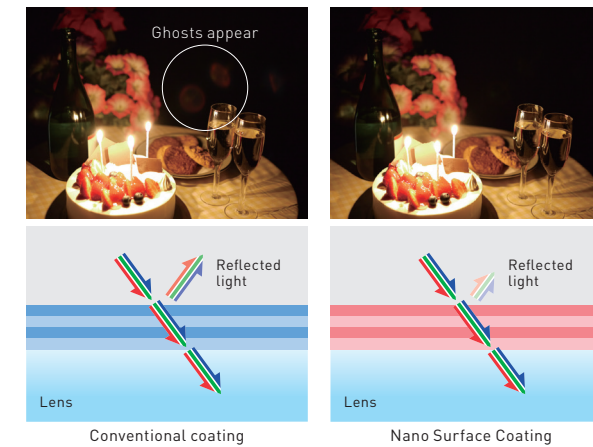

Dual I.S.



With Panasonic’s new stabilization technology, larger camera movements – previously always difficult to control without a tripod or rig – are now compensated for. Information on camera shake at the moment of shooting is transmitted at high-speed and simultaneously drives anti-shake image stabilization within both camera lens and body. This new and more advanced technology produces crystal clear images and applies not only to hand-held stills shooting but also to video recording (including 4K video). The blur of camera shake is removed through the entire shooting range from wide-angle to telephoto, offering users greater confidence and assurance when shooting challenging subjects.

*Correction range indicated is an example and varies according to lens used. (GX80 / 85,14-140mm lens when mounted, compared with wide end)

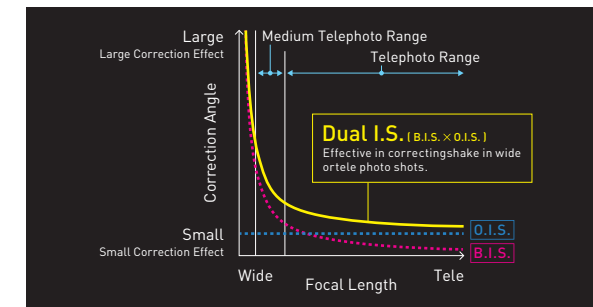

POWER O.I.S. / MEGA O.I.S. (Optical Image Stabilizer)

Built with highly effective image stabilization, interchangeable LUMIX lenses are designed to ensure high-quality images in any shooting situation, correcting for camera-shake or vibration to give you a more comfortable shooting experience during actual shooting or in Live View – even when not using a LUMIX camera. Some feature a high-precision gyro sensor for higher pixel count devices. The calculation processing of camera shake data and correction control algorithms have been optimized and any slight mismatch between the amount of camera-shake and gyro-sensor compensation is adjusted in an instant. All in all, the tiniest jitter is detected and shake compensation highly accurate so that blur is minimized during those more challenging shoots.

Contrast AF with DFD (Depth From Defocus) Technology

Panasonic’s originally developed DFD technology enables ultra-high-speed distance measurement. A simple focusing operation immediately shows the distance information of all the subjects displayed on the monitor, so you can instantly focus on the desired subject. Combining this with Panasonic’s accumulation of Contrast AF technology has made it possible to achieve faster, more precise auto-focusing to avoid missing those fleeting shutter opportunities. Also, because the distance information is constantly acquired and refreshed, subjects that have been measured once are not lost, even when shooting videos, so you enjoy smooth AF tracking without background or foreground defocusing. Achieving this technology requires high-speed, high-precision lens drive control, and the ability to accurately grasp the focusing data of each lens. By storing this data in the camera’s image processing LSI, Panasonic has attained the world’s first application of this technology to a digital camera AF system. By combining ultra-high-speed DFD technology with conventional, high-precision Contrast AF, we have optimized Contrast AF performance.

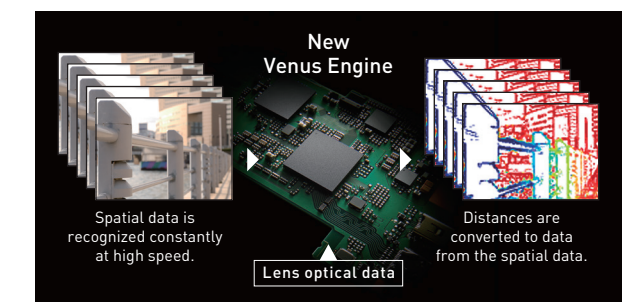
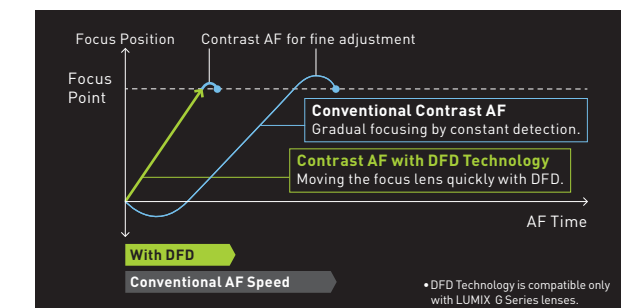

High-speed, High-precision AF Control

S series lenses achieve 480-fps high-speed AF, the G series up to 240-fps, with high-precision focus on moving subjects thanks to instant contrast and peak detection. Faster camera / lens communication assures accuracy and speed.

Lens Technology

Ultrasonic Assist

Conventionally, when a lens holding frame is driven along an optical axis shaft, the slight friction between shaft and frame limits precise AF. This friction is now eliminated by vibrating the shaft ultrasonically. The vibrating element, combined with a high propulsion motor, drives the focus lens at high speed and with unprecedented precision.

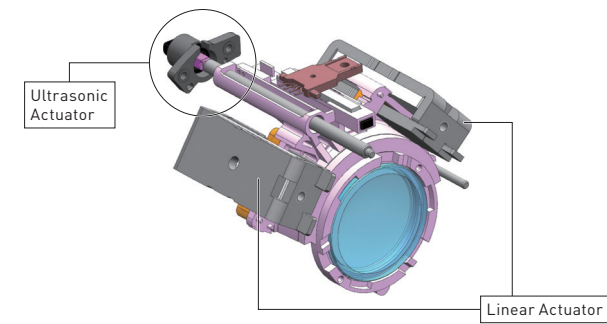

Linear Motor

Panasonic's linear motor is an electromagnetic force actuator that drives the focus lens without physical contact. As such it is utterly silent, while also achieving both high-speed and high-precision auto focus. The motor also supports shooting high-quality 4K videos even in lenses with large apertures thanks to unique feedback and hybrid controls, as well as feed forward control.

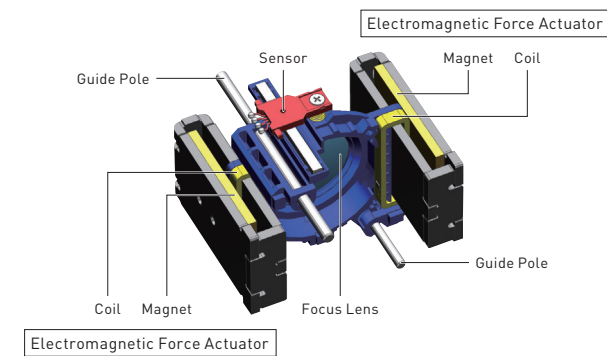

Double Focus

The focus grouping, divided into two separate moving groups, achieves high resolution whatever the subject distance. Dividing the grouping this way means less weight per group, for high-speed and high-precision AF.

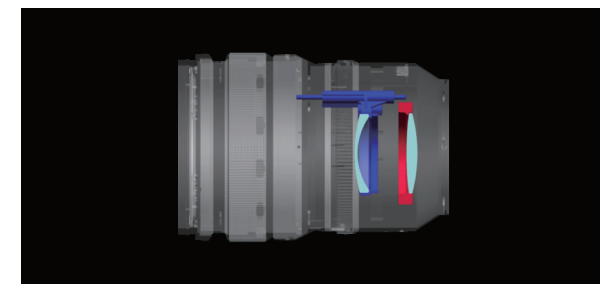

Inner Focusing

High-speed, high-precision and silent AF. The smaller, lighter, Inner Focus system delivers superb image quality, with fewer chromatic aberrations, permits shorter shoot distances and maintains angle of view.

Circular Aperture

More diaphragm blades with their shape optimized, allow a near perfect circle aperture for beautiful, natural bokeh, even at a high F-stop.

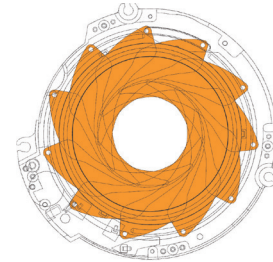

Aperture Ring

Use the lens barrel's aperture ring to intuitively adjust the F-stop when looking through the viewfinder. This is not just handy for stills photography, but a must when shooting video with moving subjects.



High-precision Manual Focusing

Instantly switch from AF to MF by simply sliding the focus ring. A clutch mechanism keeps the exact same focusing while shifting between modes.



Dust/Splash/Freeze-resistant Design

Built for mobility, the dust/splash-resistant* design of LUMIX lenses protects them outdoors, no matter the weather – even down to -10 °C on snowy mountain slopes, etc.

* mounted on a dust/splash-resistant camera body



Fluorine Coating

This special oil and water-repelling coating keeps dirt off the lens surface. Even if spray or dust do make contact, they easily wipe off. No matter the environment, your lens stays clean.

Supporting Video

The S and G series lenses are built for 4K video, with barrel optics and structure optimized for ultra-high image quality. It is easy to attach filters and operate with the focus-clutch mechanism.



Focus Breathing Suppression

For video, the disruptive focus breathing side-effect of internal focus lenses (when focal length slightly shifts) is now totally suppressed.

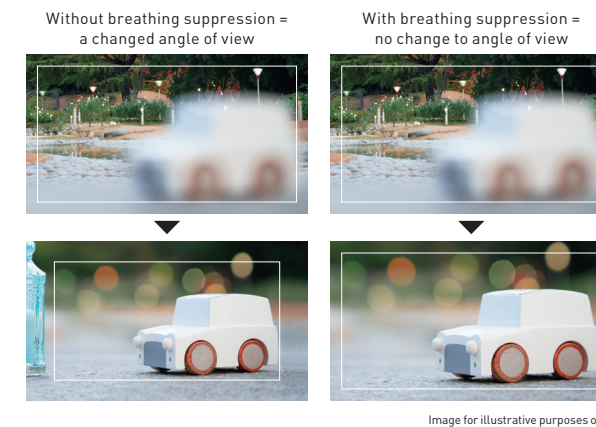

How to select a lens for shooting video

(1) Fixed Focal Length / Zoom

A fixed large-aperture lens is great for dreamy bokeh effects but use a zoom to catch key wedding or sporting moments when there's no time to change lenses.

G Series: How to choose a G Series lens for a shoot

Recommended Choice	For creating impressive bokeh, or to shoot low-noise video in low light				If you want gentler bokeh effects, or to shoot in low light and not change lens			If you need to cover a wider range of focal lengths with the minimum of lenses			For those just starting to shoot video on a DSLM
Lens Features	Fixed Focal Length Lenses (Low F-number brightness, superb resolution)				Large Aperture Zoom Lenses (Low F-number brightness, high resolution, zoom capability)			F2.8-4.0 Zoom Lenses (Greater zooming power, relatively bright F-numbers)			A High-power Zoom (wide angle - telephoto)
Product Number	H-X012	H-X015	H-XA025	H-NS043	H-X1025	H-HSA12035	H-HSA35100	H-E08018	H-ES12060	H-ES50200	H-FSA14140
Focal Length (35mm camera equivalent)	24mm	30mm	50mm	85mm	20-50mm	24-70mm	70-200mm	16-36mm	24-120mm	100-400mm	28-280mm
F-number	F1.4	F1.7	F1.4	F1.2	F1.7	F2.8	F2.8	F2.8-4.0	F2.8-4.0	F2.8-4.0	F3.5-5.6
Filter Size	62mm	46mm	46mm	67mm	77mm	58mm	58mm	67mm	62mm	67mm	58mm
Focus Breathing Suppression	●	●	●		●	●		●	●	●	●
Micro-step Aperture Control			●		●	●	●	●	●	●	●
Linear Motor								●	●		
Other/Misc.					Clickless Aperture Ring						

*All S Series (full-frame) lenses suppress focus breathing and come with micro-step aperture control

(2) Low F-numbers

Choose a lower, brighter F-stop for a range that will greatly blur backgrounds. High image-quality even in low light, without increased ISO.

(3) Focus Motor

The built-in linear motor enables high-precision, high-speed focusing that is smoother and more silent, thereby achieving high-quality video shooting.

(4) Filter Compatible

Lenses are filter-mountable for attaching useful filter effects, including ND and PL filters.

Compatible with Filters

Using a low F-number to achieve bokeh in bright daylight can result in overexposure. For beautiful blur, use the ND filter to reduce the amount of light.

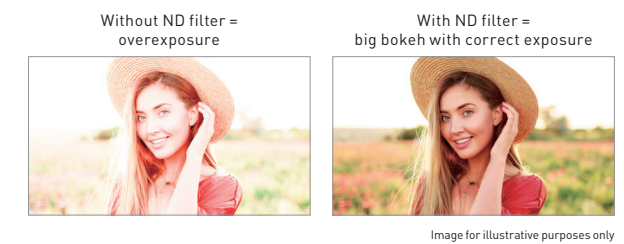

Micro-step Aperture Control

Allowing finer aperture adjustments this control lets videographers achieve smooth, more stable, exposures – especially for scenes with dramatic lighting changes or when zooming and panning.

Linear / Non-linear Focus Ring Control (S Series only)

For manual focusing, choose either "non-linear" response – focus changes to match how fast you rotate the focus ring – or "linear" – a fixed speed change irrespective of operating speed. On video shoots, select "linear" and a rotation to achieve the precise focus you want.

Lens Knowledge

Things you should know about lenses to maximize your photographic enjoyment.

What do 'angle of view' and 'focal length' mean ?

The angle of view is the area of the image captured by the image sensor, expressed as an angle. The larger the angle of view, the shorter the focal length. The smaller the angle of view, the longer the focal length. A lens with a short focal length and a large angle of view is called a wide-angle lens. A lens with a long focal length and a small angle of view is called a telephoto lens. In the LUMIX G, the diagonal dimension of the image sensor has been downsized to half that of a 35mm film frame, so the focal length is twice as long when converted to that of a 35mm camera. For example, the angle of view for a LUMIX G 25mm lens is 47°, which is the same as the angle of view for a 50mm lens on a 35mm camera.



* Figures in parentheses are 35mm camera equivalent values.

What does 'F-number' mean?

Lens brightness is determined by the focal length and effective lens diameter. If you divide the focal length by the effective lens diameter, you get a value called the F-number. The lower the F-number, the larger the aperture and the more light that passes through the lens. A lens with a lower F-number has several key advantages. For example, lenses with a lower F-number let you use a faster shutter speed, so you can get clear, blur-free shots even in dim lighting. They also let you give the background a defocus.

What does 'depth of field' mean?

Depth of field is the range of object distances (in the depth direction) within which objects have acceptable sharpness. A long focal length (telephoto lens) or small F-number makes the depth of field shallower. A short focal length (wide-angle lens) or large F-number makes the depth of field greater. With a shallow depth of field, it's easier to take pictures in which the background is intentionally given a defocus, thus emphasizing the sharp subject focus. With a large depth of field, you can keep objects in both the foreground and background all in focus (for a pan-focus effect).

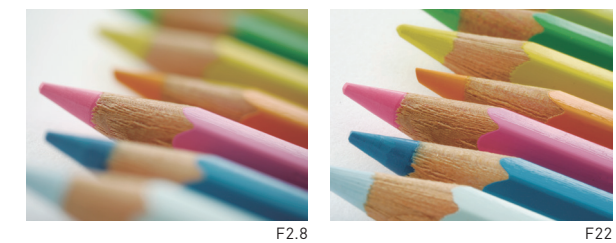

What does 'perspective' mean?

Perspective refers to the relationship between nearby and distant objects. A wide-angle lens makes objects close to the lens appear larger and faraway objects smaller. This emphasizes the distance (depth) between nearby and distant objects, making the background appear farther away and expansive. A telephoto lens, on the other hand, compresses the perspective, thus deemphasizing the distance between objects in the foreground and objects in the background.

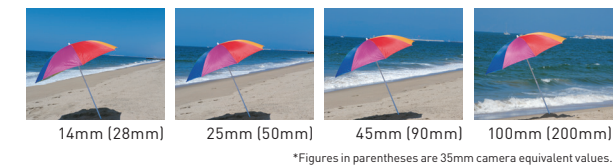

* Figures in parentheses are 35mm camera equivalent values.

What does 'magnification ratio' mean?

The magnification ratio is a numerical value that indicates the size difference between the actual size of an object and the size of that object captured on the image sensor. For example, if a 10-mm object is captured in a 5-mm size on the image sensor through a lens, that lens has a magnification ratio of 0.5x. If the object is captured in a 10-mm size, the lens has a magnification ratio of 1.0x, which is also referred to as "1:1."

* The maximum image magnification of a Micro Four Thirds System lens can be converted into the maximum image magnification of a 35mm camera lens by multiplying "the indicated maximum image magnification x 2".



What does 'MTF' mean?

MTF stands for Modulation Transfer Function. It's one of the indexes used to describe lens performance. The MTF is a numerical value that indicates how accurately a lens can reproduce the contrast of an object. The vertical axis of the graph shows contrast reproducibility (%), while the horizontal axis indicates the distance (mm) from the image center. The image quality is evaluated in the sagittal direction "S" (parallel to the radius of the image circle) and in the meridional direction "M" (radial direction) using two frequencies (high frequency: 40 lines/mm, low frequency: 20 lines/mm). The solid lines represent sagittal measurements, and the dotted lines indicate meridional measurements. The higher up (100%) the graph, the better the image rendering capability of the lens. The higher the measurements with the low frequency, the higher the contrast reproduction capability. The higher the measurements with the high frequency, the higher the resolving power.

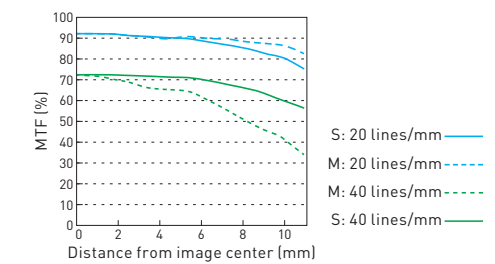

Lens Designation

The key specifications of each LUMIX lens are incorporated within the name it is given. They serve as a quick reference for choosing the lens you need.

LUMIX S Series Lens

LUMIX S 24-105mm F4 MACRO O.I.S.

① ④ ⑤ ③ ⑦

LUMIX G Series Lens

LUMIX G X VARIO PZ 45-175mm/ F4.0-5.6 ASPH./POWER O.I.S.

① ② ③ ④ ⑤ ⑥ ⑦

- ① Name of the lens series**
Available LUMIX interchangeable lenses include the L-Mount system lenses of the LUMIX S PRO and LUMIX S line-ups for full-frame DSLM cameras, as well as the Micro Four Thirds system lenses of the LEICA DG, LUMIX G X and LUMIX G line-ups.
- ② Name for a zoom lens**
This indicates a zoom lens product (for Micro Four Thirds system cameras).
- ③ Lens features**
This indicates that the lens has a power-zoom, macro function, or the minimum aperture values between wide and tele.
- ④ Focal length(s)**
The smaller the focal length, the wider the angle of view (wide angle). The larger the focal length, the smaller the angle of view (telephoto). The number on the left is the focal length at the wide-angle setting, and the number on the right is the focal length at the telephoto setting.
- ⑤ F-number(s)**
The smaller the F-number, the brighter the lens. The number on the left is the F-number for the fully opened aperture at the wide-angle setting, and the number on the right is the F-number for the fully opened aperture at the telephoto setting. (The F-number takes an intermediate value while zooming.)
- ⑥ Aspherical lens**
"ASPH." means that the lens includes one or more aspherical lenses.
- ⑦ System to counter camera-shake**
"POWER O.I.S." [or "MEGA O.I.S."] indicates that the lens is equipped with an optical image stabilizer for hand-shake compensation.

Accessories

Expanding the LUMIX shooting experience. A wide range of accessories, such as flashes, with features that have advanced along with the camera.

Options

Battery Grip
DMW-BGS1
Compatible with S1R/S1/S1H



For extended shooting enjoyment, this grip features a joystick control. Chargeable through the camera's USB port for hours of continuous stills or video shooting, it is also built to be dust/splash/freeze-resistant to -10°C*.

*The DMW-BLJ31 battery pack is sold separately.

Battery Grip
DMW-BGG9
Compatible with G9



For extended shooting enjoyment, the joystick feature makes camera operation as easy vertically as it is horizontally. This is perfect for long-hours shooting in the field and built to be dust/splash/freeze-resistant to -10°C*.

*The DMW-BLF19 battery pack is sold separately.

Battery Grip
DMW-BGGH5
Compatible with GH5/GH5S



For extended shooting enjoyment, the joystick on the back brings effortless operability to control focus and a more comfortable experience to vertical shooting. Designed to be dust/splash-resistant***.

*The DMW-BLF19 battery pack is sold separately.

Battery Grip
DMW-BGGH3
Compatible with GH4



For extended shooting enjoyment and built with a dust/splash-resistant design* this battery grip boasts effortless operation capabilities, even when holding the camera vertically.

*The DMW-BLF19 battery pack is sold separately.

Battery Grip
DMW-BGG1
Compatible with G8/G99



For extended shooting enjoyment. The design makes holding the camera for vertical shooting as easy as for horizontal, and the construction is dust/splash-resistant*.

*A DMW-BLC12 battery pack is included.

Stereo Shotgun Microphone
DMW-MS2
Compatible with S1R/S1/S1H/
GH4/GH5/GH5S/G7/G8/G9/G99



Switch easily between a Stereo Microphone and Stereo Shotgun Microphone.

Stereo Microphone
VW-VMS10
Compatible with S1R/S1/S1H/
GH4/GH5/GH5S/G7/G8/G9/G99



Easy to carry and very handy for casual recording.

LED Video Light
VW-LED1
Compatible with
S1R/S1/S1H/GH4/GH5/
GH5S/G7/G8/G9/G99/
GX8/GX7 MKII/GX7 MKIII



The LED Video Light comprises 36 high-intensity white LEDs. It attains a brightness of about 1,500 lux at a distance of 50 cm from the subject. Natural lighting is cast not only in the center of the frame, but all the way to the corners. The brightness is also adjustable, so you can select the level that matches your shooting intent. The light is powered by four AA batteries, and the low power consumption of LEDs enables approximately 240 minutes of continuous lighting (using Nickel-Metal Hydride batteries).

XLR Microphone Adaptor
DMW-XLR1
Compatible with S1R/S1/S1H/GH5/GH5S



With a 2-channel XLR microphone attached the DMW-XLR1 enables highgrade stereo surround recording for professional video production. The adaptor supports 96kHz/24bit hi-res sound recording and is ideal for lipsync projects. It is designed to be easy to use with physical switches and dials for immediate setting and checking. DC power is supplied via the shoe connector.

*Microphones not included with the DMW-XLR1.

Remote Shutter
DMW-RS2
Compatible with S1R/S1/S1H/
GH5/GH5S/G8/G9/G99



Allows remote operation for long exposures and can also be used as a release to start video recording. The cable is 80 cm long and comes, additionally, with a 2 m extension and grip holder.

Tripod Adaptor
DMW-TA1



When a large-diameter lens is mounted, this adaptor prevents the lens from contacting the tripod base.

Eyecups
DMW-EC6
Compatible with S1R/S1/S1H



The eyecups provide cushioning around the camera's viewfinder for added comfort and most importantly to reduce glare by cutting out extra light between view finder and eye.

DMW-EC3
Compatible with GX8



DMW-EC4
Compatible with G9



DMW-EC5
Compatible with GX7 MKIII



Teleconverters

Compatible with interchangeable L-Mount system lenses

1.4x Teleconverter*
DMW-STC14

The focal length is boosted a useful 1.4 times without sacrificing the superb optical performance of the original interchangeable lens. Designed to be dust/splash/freeze-resistant***.

Compatible with: S-E70200, S-R70200****
Lens Construction: 7-4 (2 UHR lenses) Focal Length: 1.4x
Diameter (Φ) x Length (mm/in): Φ 65.3 x 27.6 / 2.57 x 1.09
Weight (g/oz): 180 / 6.35



2x Teleconverter**
DMW-STC20

This doubles focal length to give the reach of a super telephoto while achieving excellent image quality and the maneuverability of the original lens. Designed to be dust/splash/freeze-resistant***.

Compatible with: S-E70200, S-R70200****
Lens Construction: 8-4 (2 UHR lenses) Focal Length: 2x
Diameter (Φ) x Length (mm/in): Φ 65.3 x 41.6 / 2.57 x 1.64
Weight (g/oz): 230 / 8.11



Compatible with interchangeable Micro Four Thirds system lenses

1.4x Teleconverter*
DMW-TC14

You can shoot telephoto style with 1.4 times greater focal length and still achieve the same high-quality images. Designed to be dust/splash-resistant****.

Compatible with: H-ES200/H-ES50200
Lens Construction: 6-4 Focal Length: 1.4x
Diameter (Φ) x Length (mm/in): Φ58 x 22 / 2.28 x 0.87inch
Weight (g/oz): 120 / 4.23



2x Teleconverter**
DMW-TC20

This doubles the focal length and turns your lens into a high-quality super telephoto. Designed to be dust/splash-resistant****.

Compatible with: H-ES200/H-ES50200
Lens Construction: 8-5 Focal Length: 2x
Diameter (Φ) x Length (mm/in): Φ58 x 34 / 2.28 x 1.34
Weight (g/oz): 160 / 5.64



Mount Adapter

Enables the use of lenses other than those of the Micro Four Thirds System standard.

M Mount Adaptors
DMW-MA2M

Allows Leica M mount lenses to be mounted onto a Micro Four Thirds camera.

Max. Diameter: 61mm, Length: 13mm, Weight: 60g



When using the DMW-MA2M mount adaptor please note:

- iA (Intelligent Auto) mode cannot be used.
- In the Custom Menu, make sure you have "Shoot w/o Lens" set to ON.

Filters

ND (Neutral Density) Filter (ND8)

Lets you use slower shutter speeds even in the bright outdoors, and reduces light intensity by three aperture stops.

62mm DMW-LND62
58mm DMW-LND58
52mm DMW-LND52

46mm DMW-LND46
37mm DMW-LND37



* Dust and splash resistance does not guarantee that damage will not occur if this accessory is subjected to direct contact with dust and water. ** LUMIX G system cameras come with a function to check whether the battery and unit can be safely used together. *** Batteries made by other companies which have been certified by Panasonic may be used with these units, but we offer no guarantee as to the quality, performance or safety of such batteries. **** Exercise care when purchasing batteries. Many fake or imitation batteries have been found among those sold at unusually low prices and those which customers cannot check for themselves before purchasing.

* With the teleconverter attached the aperture and brightness is reduced by one f/stop. ** With the teleconverter attached the aperture and brightness is reduced by two f/stops. *** When mounted on a splash/dust-resistant full-frame mirrorless LUMIX camera body with interchangeable-lens. **** Compatible with firmware version 1.1 or later. ***** When mounted on a splash/dust-resistant Micro Four Thirds LUMIX camera body with interchangeable-lens.

External Flashes

Wireless compatible external flashes with LED lighting

DMW-FL580L (GN58)



Battery Recommended	AA Alkaline dry batteries (LR6) x 4 / AA Rechargeable nickel metal hydride batteries (Ni-MH) x 4						
Charging Time (from full flash until the [TEST/CHARGE] lamp lights) (with full flash)	Approx. 2.7 sec: AA Alkaline dry batteries Approx. 1.7 sec: AA Rechargeable nickel metal hydride batteries						
Number of Flashes (Approx.) (with full flash)	125 flashes or more: AA Alkaline dry batteries 175 flashes or more: AA Rechargeable nickel metal hydride batteries (min. 1,900 mAh typical) (differs depending on the photo taking conditions)						
Flash Mode	TTL AUTO / AUTO / MANUAL / FP TTL AUTO / FP MANUAL						
Guide Number	58 (ISO100-m), 26 (ISO100-m, when the wide panel is used)						
Lighting Angle	Covers the angle of view of 12 - 100mm lenses (35mm camera equivalent: 24 - 200mm) (with wide panel: 7mm lens, 35mm camera equivalent: 14mm)						
LED	<table border="1"> <tr> <td> Illuminance</td> <td>Approx. 100 lux at 1 m</td> </tr> <tr> <td> Lighting Angle</td> <td>Compatible with lenses having a focal length of more than 12mm/24mm* *35mm camera equivalent</td> </tr> <tr> <td> Control Mode</td> <td>AUTO / MANUAL</td> </tr> </table>	Illuminance	Approx. 100 lux at 1 m	Lighting Angle	Compatible with lenses having a focal length of more than 12mm/24mm* *35mm camera equivalent	Control Mode	AUTO / MANUAL
Illuminance	Approx. 100 lux at 1 m						
Lighting Angle	Compatible with lenses having a focal length of more than 12mm/24mm* *35mm camera equivalent						
Control Mode	AUTO / MANUAL						
Wireless (RC) Function	<table border="1"> <tr> <td> Flash Mode</td> <td>SL AUTO / SL MANUAL / RC / MULTI</td> </tr> <tr> <td> Channel</td> <td>4 channels</td> </tr> <tr> <td> Group</td> <td>3 groups control</td> </tr> </table>	Flash Mode	SL AUTO / SL MANUAL / RC / MULTI	Channel	4 channels	Group	3 groups control
Flash Mode	SL AUTO / SL MANUAL / RC / MULTI						
Channel	4 channels						
Group	3 groups control						
Bounce Angle	<table border="1"> <tr> <td> Up / Down</td> <td>Upward: 0 - 90 degrees / Downward: 0 - 7 degrees</td> </tr> <tr> <td> Right / Left</td> <td>Toward the right: 0 - 180 degrees / Toward the left: 0 - 180 degrees</td> </tr> </table>	Up / Down	Upward: 0 - 90 degrees / Downward: 0 - 7 degrees	Right / Left	Toward the right: 0 - 180 degrees / Toward the left: 0 - 180 degrees		
Up / Down	Upward: 0 - 90 degrees / Downward: 0 - 7 degrees						
Right / Left	Toward the right: 0 - 180 degrees / Toward the left: 0 - 180 degrees						
Dimensions (W x H x D)	Approx. 72.0 x 112.5 x 112.5 mm (excluding the projecting parts)						
Weight	Approx. 435 g/15.34 oz (including alkaline dry batteries) Approx. 340 g/11.99 oz (main unit)						

The GN58 flash delivers a powerful lighting punch. With wireless remote and auto / manual controls, this unit also features high-speed charging (a mere 1.7 seconds recycle) for shooting portrait stills in rapid succession.

DMW-FL360L (GN36)



Battery Recommended	LR6/AA Alkaline dry batteries x 4 / HR6/AA Rechargeable nickel metal hydride batteries (Ni-MH) x 4						
Charging Time (from full flash until the [TEST/CHARGE] lamp lights) (with full flash)	Approx. 2.0 sec: LR6/AA Alkaline dry batteries Approx. 1.5 sec: HR6/AA Rechargeable nickel metal hydride batteries						
Number of Flashes (Approx.) (with full flash)	250 flashes or more: LR6/AA Alkaline dry batteries 350 flashes or more: HR6/AA Rechargeable nickel metal hydride batteries (min. 1,900 mAh typical) (differs depending on the photo taking conditions)						
Flash Mode	TTL AUTO / AUTO / MANUAL / FP TTL AUTO / FP MANUAL / SL AUTO / SL MANUAL / RC						
Guide Number	36 (ISO100-m), 12 (ISO100-m when the wide panel is used)						
Lighting Angle	Covers the angle of view of 12 - 42mm lenses (35mm camera equivalent: 24 - 85mm) (with wide panel: 8mm lens, 35mm camera equivalent: 16mm)						
LED	<table border="1"> <tr> <td> Illuminance</td> <td>Approx. 100 lux at 1 m</td> </tr> <tr> <td> Lighting Angle</td> <td>Compatible with lenses having a focal length of more than 12mm/24mm* *35mm camera equivalent</td> </tr> <tr> <td> Control Mode</td> <td>AUTO / MANUAL</td> </tr> </table>	Illuminance	Approx. 100 lux at 1 m	Lighting Angle	Compatible with lenses having a focal length of more than 12mm/24mm* *35mm camera equivalent	Control Mode	AUTO / MANUAL
Illuminance	Approx. 100 lux at 1 m						
Lighting Angle	Compatible with lenses having a focal length of more than 12mm/24mm* *35mm camera equivalent						
Control Mode	AUTO / MANUAL						
Wireless (RC) Function	<table border="1"> <tr> <td> Flash Mode</td> <td>RC / SL AUTO / SL MANUAL</td> </tr> <tr> <td> Channel</td> <td>4 channels</td> </tr> <tr> <td> Group</td> <td>3 groups control</td> </tr> </table>	Flash Mode	RC / SL AUTO / SL MANUAL	Channel	4 channels	Group	3 groups control
Flash Mode	RC / SL AUTO / SL MANUAL						
Channel	4 channels						
Group	3 groups control						
Bounce Angle	<table border="1"> <tr> <td> Up / Down</td> <td>Upward: 0 - 90 degrees / Downward: 0 - 7 degrees</td> </tr> <tr> <td> Right / Left</td> <td>Toward the right: 0 - 180 degrees / Toward the left: 0 - 180 degrees</td> </tr> </table>	Up / Down	Upward: 0 - 90 degrees / Downward: 0 - 7 degrees	Right / Left	Toward the right: 0 - 180 degrees / Toward the left: 0 - 180 degrees		
Up / Down	Upward: 0 - 90 degrees / Downward: 0 - 7 degrees						
Right / Left	Toward the right: 0 - 180 degrees / Toward the left: 0 - 180 degrees						
Dimensions (W x H x D)	Approx. 62.0 x 104.0 x 98.0 mm (excluding the projecting parts)						
Weight	Approx. 376 g/13.3 oz (including batteries) Approx. 287 g/9.97 oz (main unit)						

An external flash for wireless control and auto / manual modes. The GN36 covers the maximum angle of view of a 16mm (35mm camera equivalent) lens. It also features a continuous LED light for supplementary lighting when shooting video under low-light or backlit conditions.

DMW-FL200L (GN20)



Battery Recommended	LR6/AA Alkaline dry batteries x 2 / HR6/AA Rechargeable nickel metal hydride batteries (Ni-MH) x 2						
Charging Time (from full flash until the [TEST/CHARGE] lamp lights) (with full flash)	Approx. 4.0 sec: LR6/AA Alkaline dry batteries Approx. 3.0 sec: HR6/AA Rechargeable nickel metal hydride						
Number of Flashes (Approx.) (with full flash)	120 flashes or more: LR6/AA Alkaline dry batteries 200 flashes or more: HR6/AA Rechargeable nickel metal hydride batteries (min 2,400 mAh typical) (differs depending on the photo taking condition)						
Flash Mode	TTL AUTO / MANUAL / SL MANUAL / RC						
Guide Number	20 (ISO100-m), 14 (ISO100-m when the wide panel is used)						
Lighting Angle	Covers the angle of view of 12mm and longer (35mm camera equivalent: 24mm and longer) (with wide panel: 7mm and longer, 35mm camera equivalent: 14mm and longer)						
LED	<table border="1"> <tr> <td> Illuminance</td> <td>Approx. 200 lux at 1 m</td> </tr> <tr> <td> Lighting Angle</td> <td>Compatible with lenses having a focal length of more than 12mm/24mm* *35mm camera equivalent</td> </tr> <tr> <td> Control Mode</td> <td>MANUAL</td> </tr> </table>	Illuminance	Approx. 200 lux at 1 m	Lighting Angle	Compatible with lenses having a focal length of more than 12mm/24mm* *35mm camera equivalent	Control Mode	MANUAL
Illuminance	Approx. 200 lux at 1 m						
Lighting Angle	Compatible with lenses having a focal length of more than 12mm/24mm* *35mm camera equivalent						
Control Mode	MANUAL						
Wireless (RC) Function	<table border="1"> <tr> <td> Flash Mode</td> <td>RC / SL MANUAL</td> </tr> <tr> <td> Channel</td> <td>4 channels</td> </tr> <tr> <td> Group</td> <td>3 groups control</td> </tr> </table>	Flash Mode	RC / SL MANUAL	Channel	4 channels	Group	3 groups control
Flash Mode	RC / SL MANUAL						
Channel	4 channels						
Group	3 groups control						
Bounce Angle	<table border="1"> <tr> <td> Up / Down</td> <td>0 - 90 degrees</td> </tr> <tr> <td> Right / Left</td> <td>-</td> </tr> </table>	Up / Down	0 - 90 degrees	Right / Left	-		
Up / Down	0 - 90 degrees						
Right / Left	-						
Dimensions (W x H x D)	Approx. 61.0 x 52.5 x 82.0 mm (excluding the projecting parts)						
Weight	Approx. 230 g / 8.11 oz (including batteries) Approx. 180 g / 6.35 oz (main unit)						

This LUMIX flash is stylish down to its high-quality finish. With a head that rotates for bounce shooting, the GN20 is both powerful for stills photography while also equipped with two powerful LED lights for shooting video under low-light conditions.

Wireless Control

LUMIX external flashes incorporate wireless control functions that enable powerful multiple flash lighting with up to three flash groups. Settings such as firing, dimming and exposure compensation can be configured via the camera menu. The units may also be used as slave flashes.

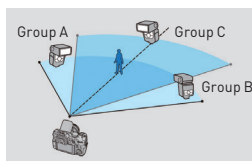

LED Lighting in Video Shooting

LUMIX external flashes also feature LED lights that are especially useful for shooting videos under backlit or low-light conditions.

Flash Knowledge

Use a flash to freely control the light best suited to your subject.

LUMIX's external flash adds to the expressive capabilities made possible by light control. Shots that cannot be taken with the camera's internal flash alone, such as those in dark places or when directly facing the light source, come out clear and sharp with the external flash. It is ideal for a number of advanced lighting techniques, such as smoothening shadows with bounce lighting for a more natural effect, wireless shooting from a place some distance from the camera, and defocusing the background or using a high shutter speed.

Image showing flash throw distance

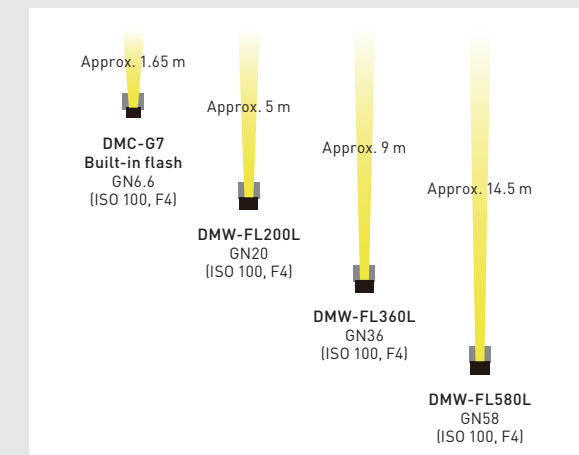

GN (Guide Number) and Shooting Distance

The GN (guide number) indicates the furthest distance the flash light can reach. The higher the GN, the more light produced for lighting up a distant subject. The GN and aperture value (F-number) let you calculate the throw distance.

Based on the GN, you can calculate how far the flash's light will reach.
Shooting Distance with Proper Exposure (m) = GN / F Value

The higher you set ISO sensitivity, the further away your subjects can be (using the appropriate exposure). For example, when shooting at ISO 400, the distance is roughly twice that reachable when you shoot at ISO 100. This lets you extend the shooting distance.

Shooting Distances with the ISO 100 Set to 1

Sensitivity	ISO 100	ISO 200	ISO 400	ISO 800	ISO 1600
Shooting Distances	1x	Approx. 1.4x	Approx. 2x	Approx. 2.8x	Approx. 4x

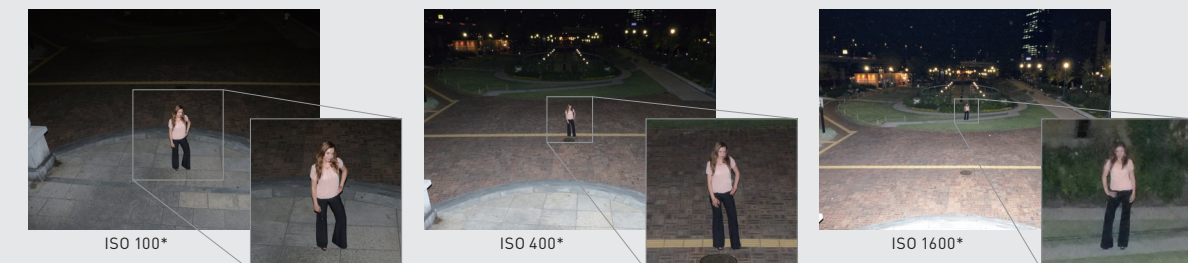

* When shooting with F2.8, 24mm wide-angle (35mm camera equivalent) settings.

Bounce Lighting

This is a shooting method in which the flash unit is rotated so that its light can be bounced off a ceiling or wall and so create a more diffuse lighting source. It softens shadows that are generated by the flash, and produces a natural lighting that enhances facial expressions and the mood of the room. Because the light does not hit the subject directly, you also avoid startling your subject.

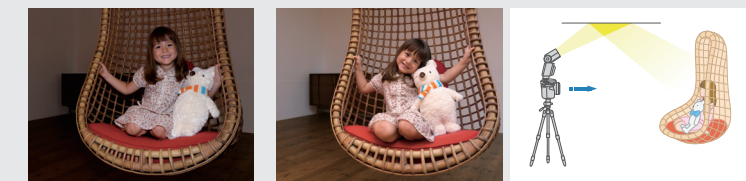

Direct lighting

Bounce Lighting

FP Emission (High-speed Sync)

Flash is useful for providing fill light to counter a strongly lit background or light source. FP emission lets you shoot at faster shutter speeds. You can also use a fully open aperture even for bright scenes.

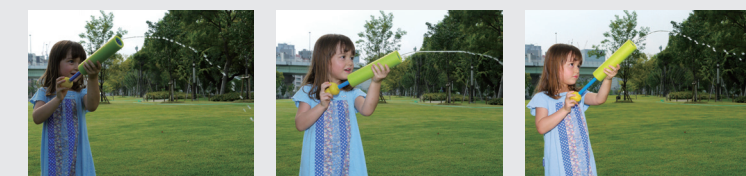

Flash OFF
Blocked shadows result from shooting against the lighting source.

TTL AUTO
Brightly corrects the image. Shows the water flow.

FP Emission
The fast shutter speed freezes the water spray.