

# Kích thước

## 1 Dàn lạnh

### 1.1 CS-XZ9XKH-8 / CS-XZ12XKH-8

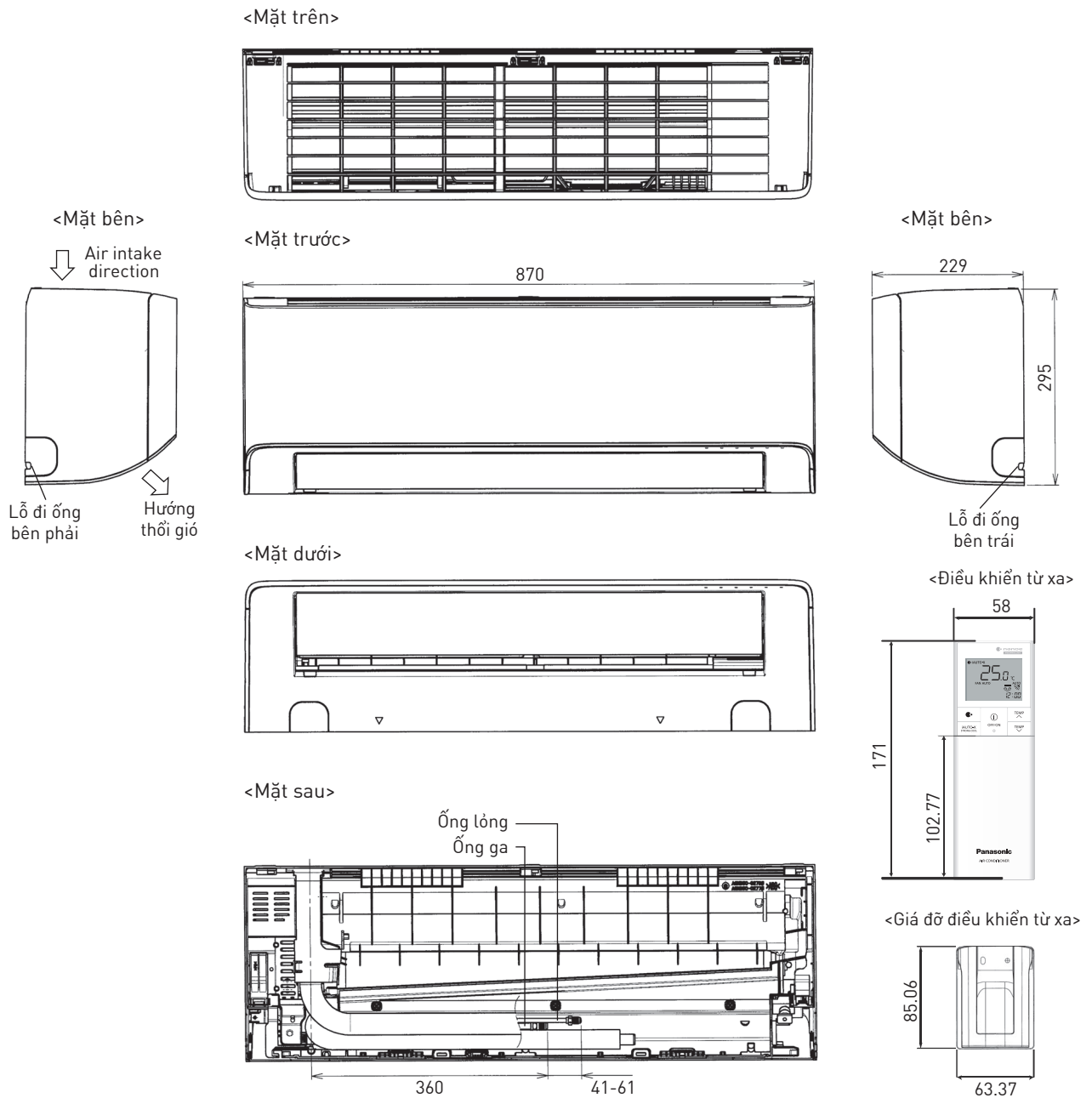

Vị trí tương đối giữa dàn lạnh và giá treo dàn lạnh <Mặt trước>

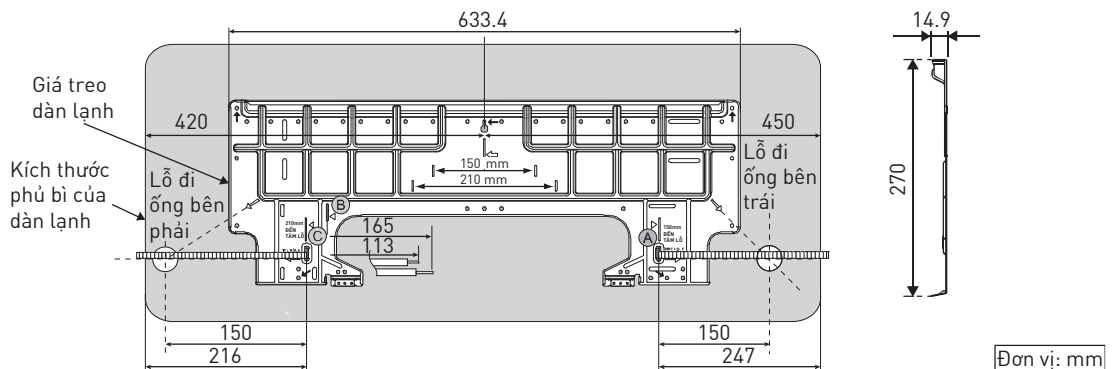

## 1.2 CS-XZ18XKH-8 / CS-XZ24XKH-8

<Mặt trên>

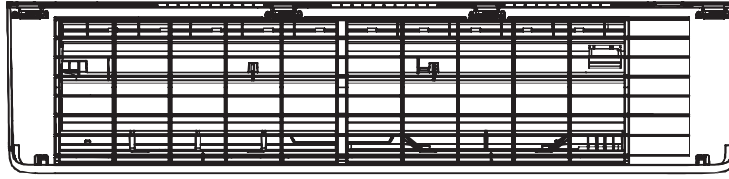

<Mặt bên>

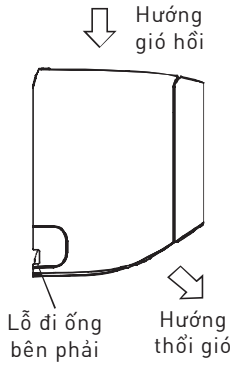

<Mặt trước>

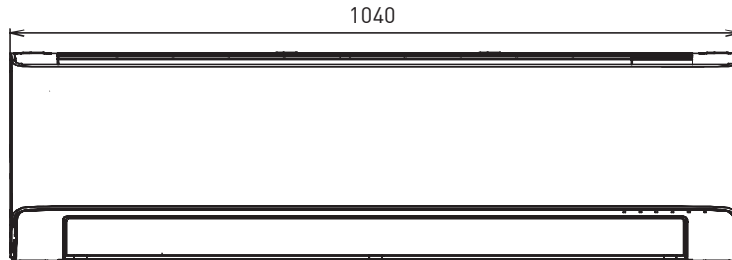

<Mặt bên>

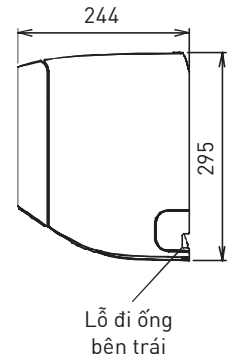

<Mặt dưới>

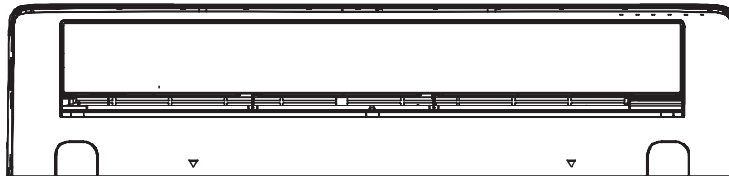

<Mặt sau>

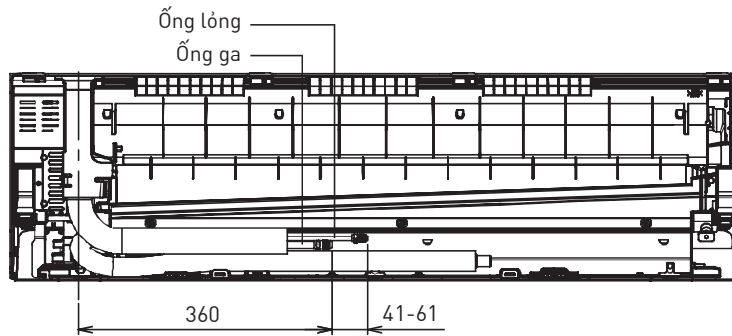

<Điều khiển từ xa>

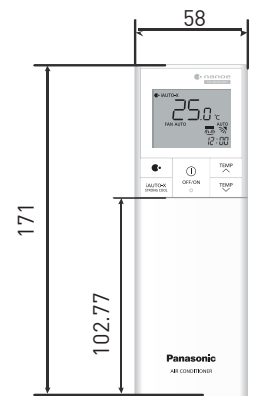

<Giá đỡ điều khiển từ xa>

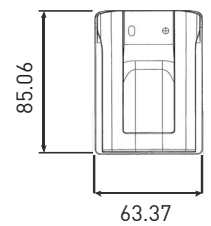

Vị trí tương đối giữa dàn lạnh và giá treo dàn lạnh <Mặt trước>

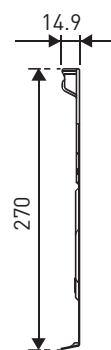
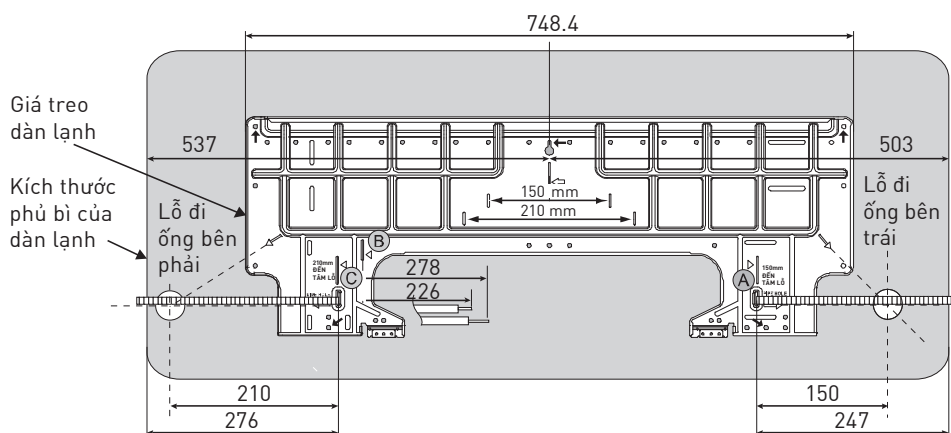

Đơn vị: mm

## 2 Dàn nóng

### 2.1 CU-XZ9XKH-8 / CU-XZ12XKH-8

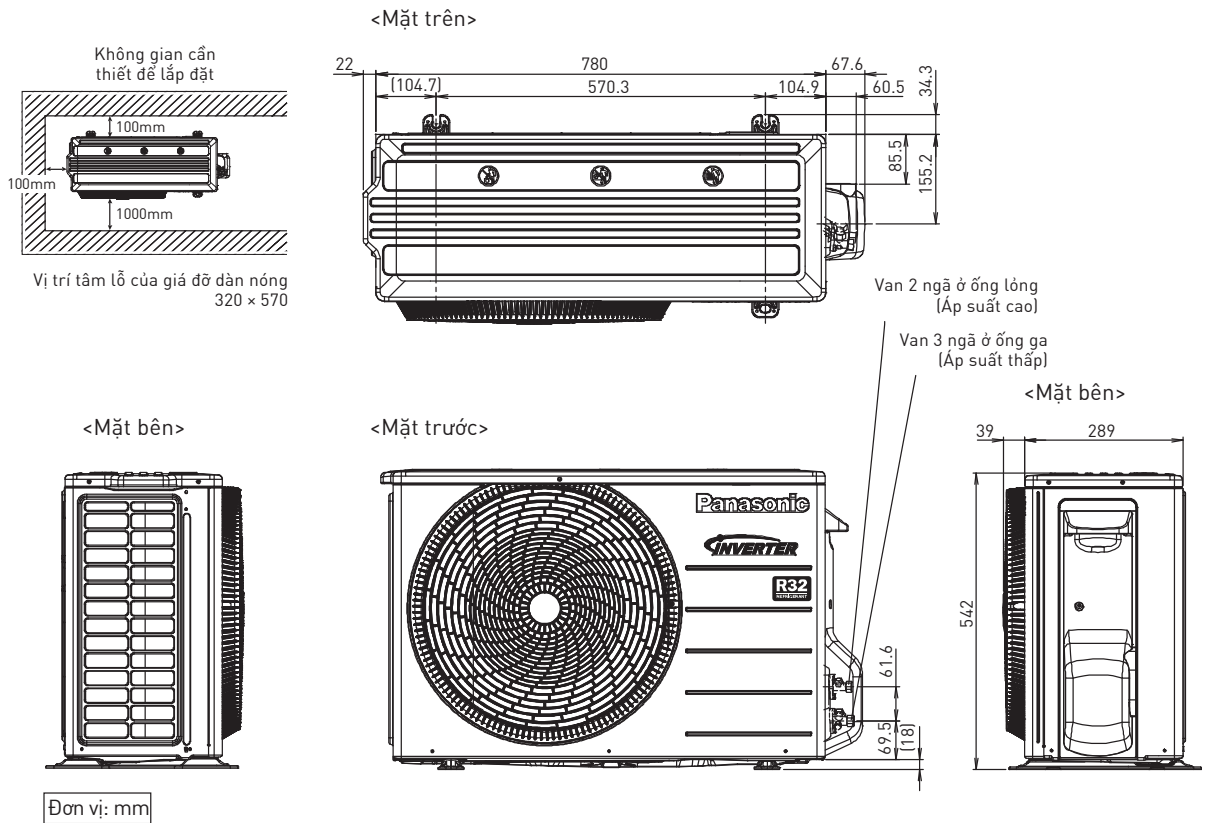

### 2.2 CU-XZ18XKH-8 / CU-XZ24XKH-8

