

Kích thước

1 Dàn lạnh

1.1 CS-XU9ZKH-8 / CS-XU12ZKH-8

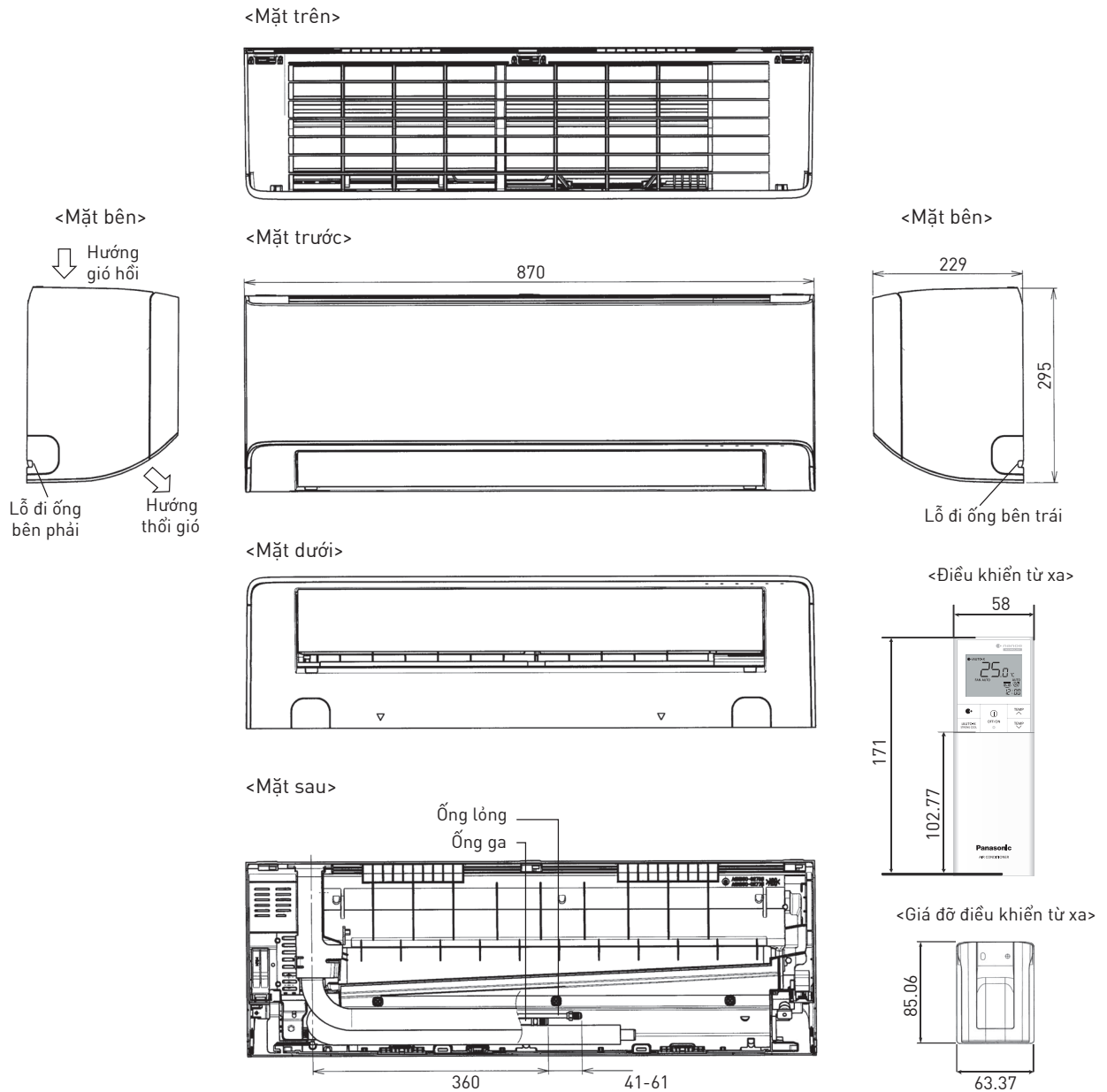

Vị trí tương đối giữa dàn lạnh và giá treo dàn lạnh <Mặt trước>

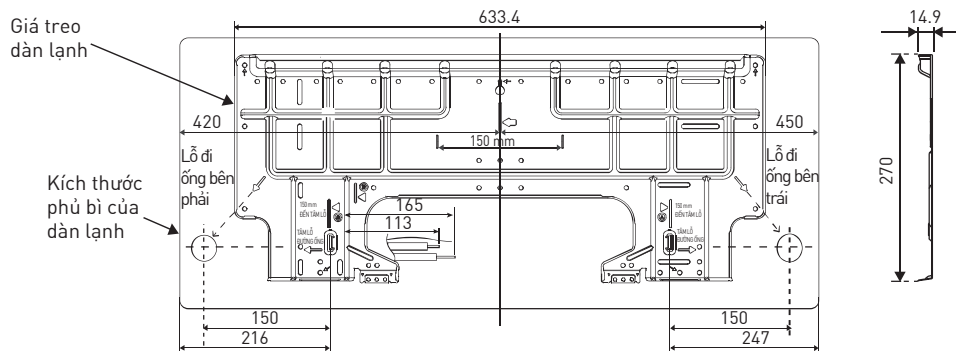

Đơn vị: mm

1.2 CS-XU18XKH-8 / CS-XU24XKH-8

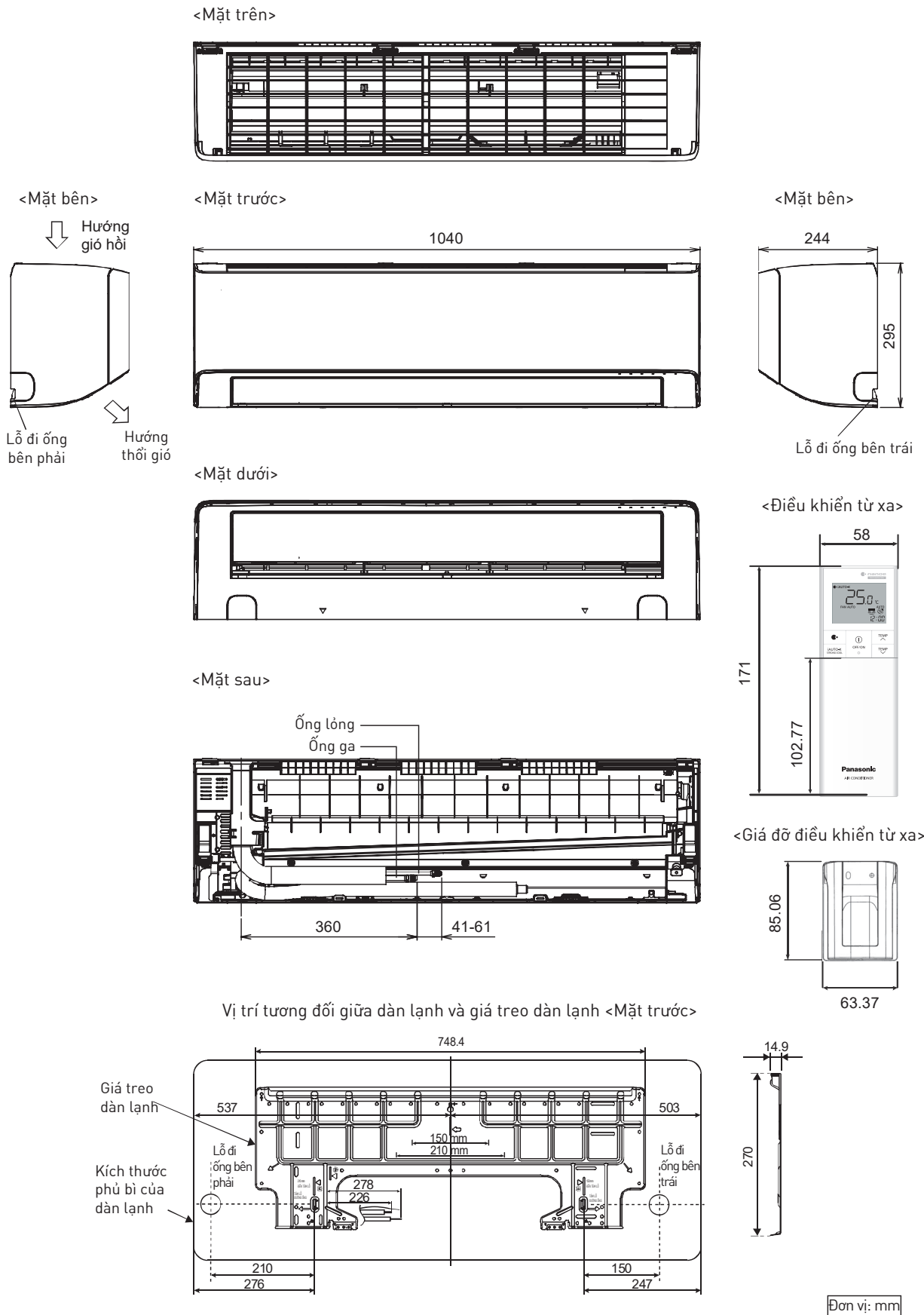

2 Outdoor Unit

2.1 CU-XU9XKH-8

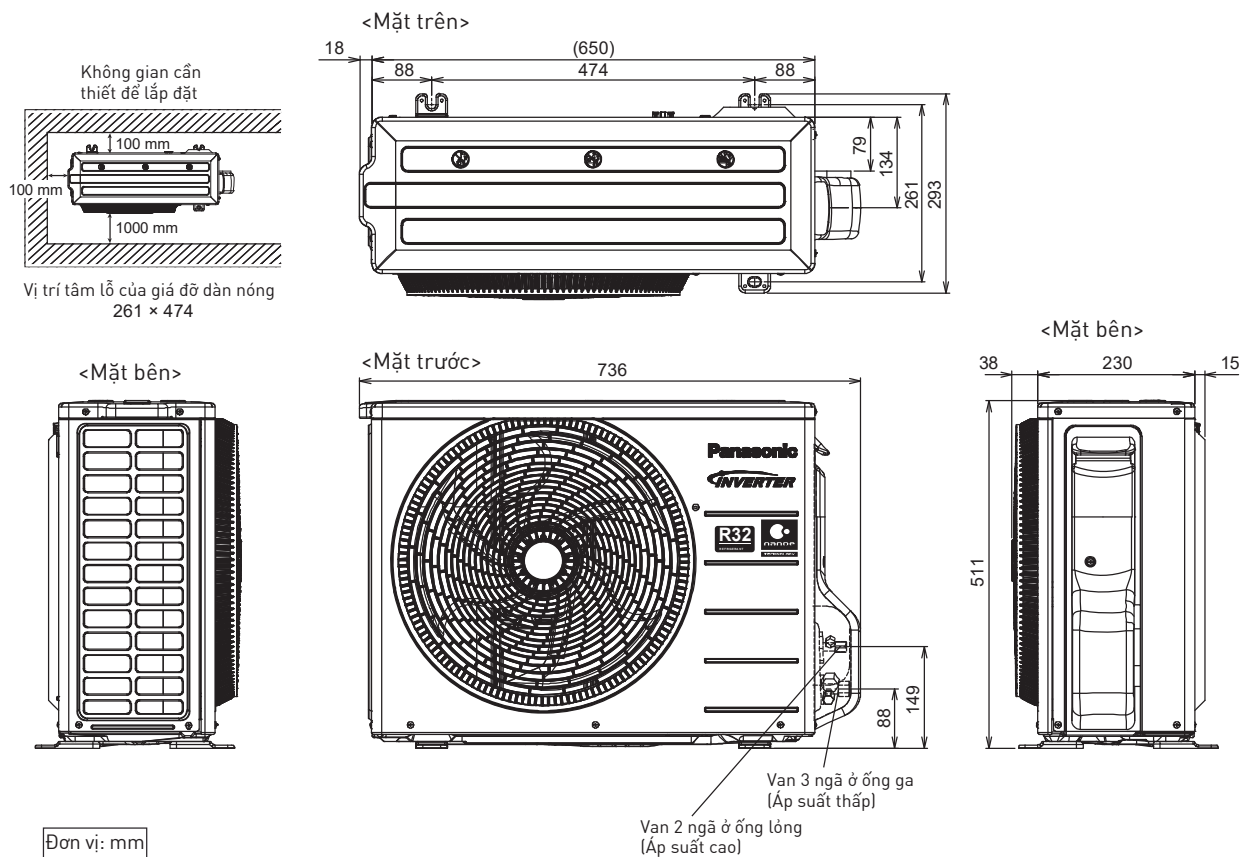

2.2 CU-XU12XKH-8

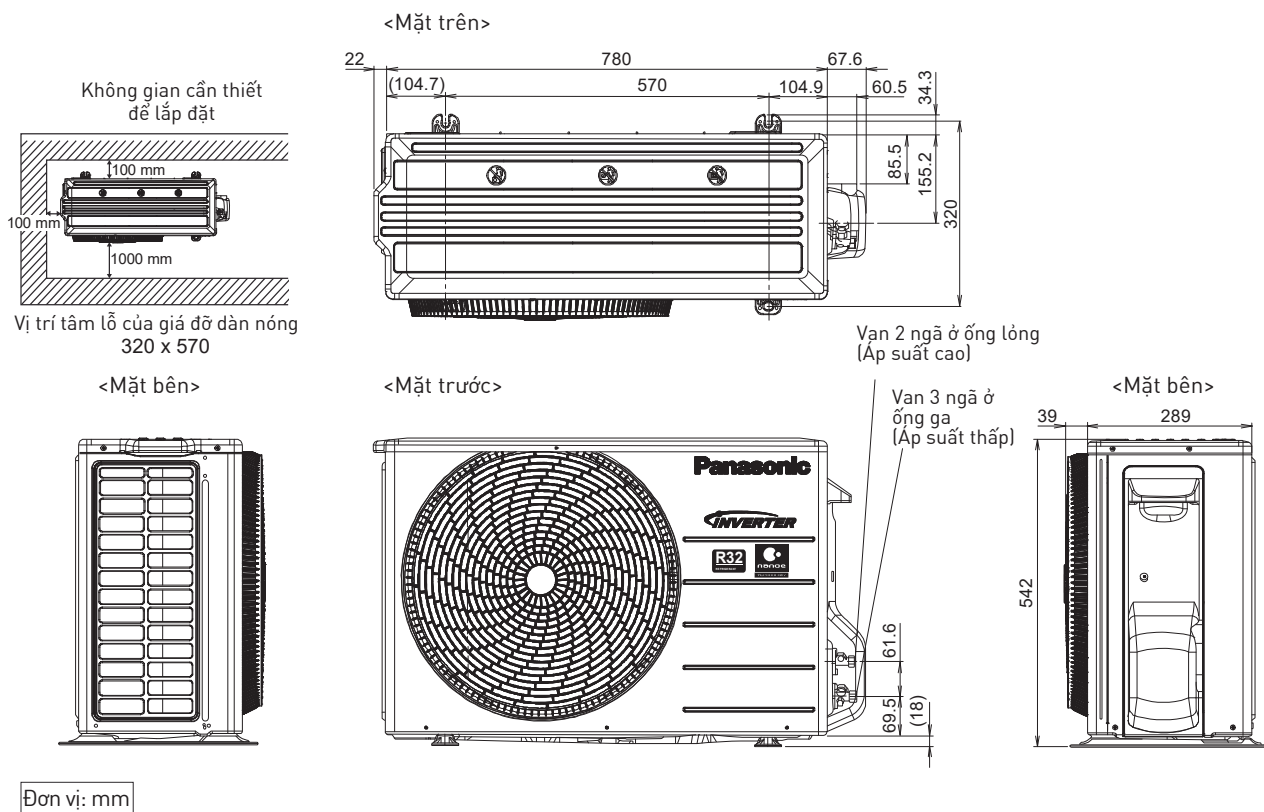

2.3 CU-XU18XKH-8

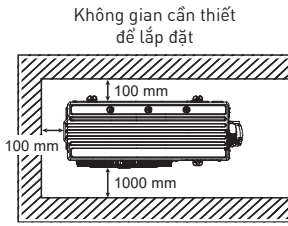

Vị trí tâm lỗ của giá đỡ dàn nóng
330 × 540

<Mặt bên>

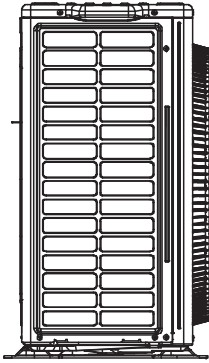

Đơn vị: mm

<Mặt trên>

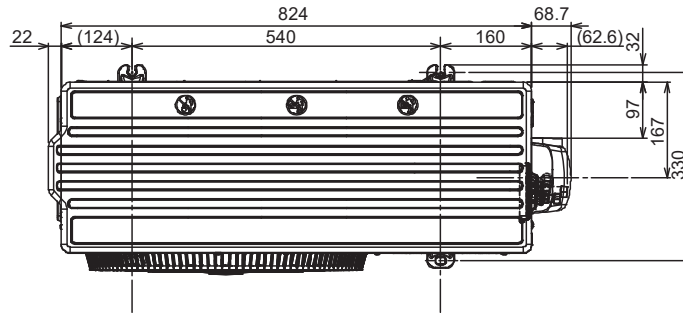

<Mặt trước>

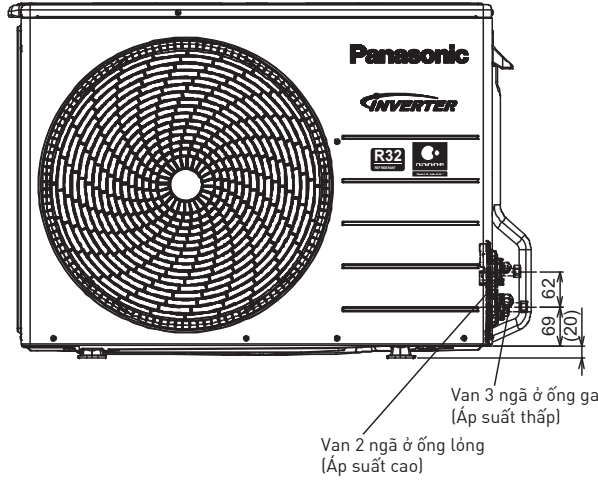

<Mặt bên>

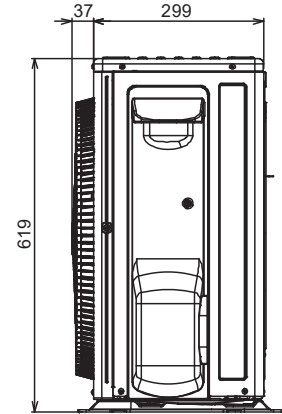

2.4 CU-XU24XKH-8

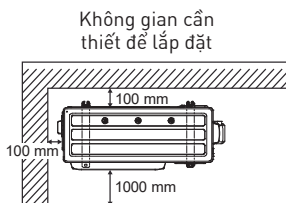

Vị trí tâm lỗ của giá đỡ dàn nóng
360.5 × 613

<Mặt bên>

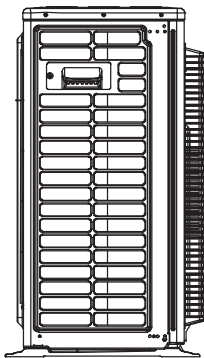

Đơn vị: mm

<Mặt trên>

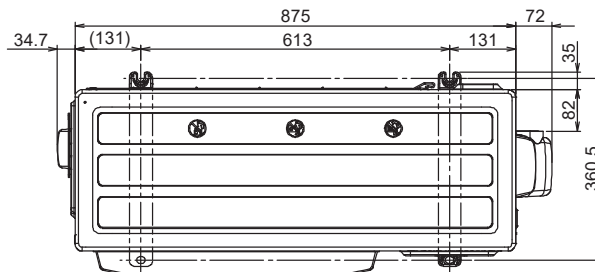

<Mặt trước>

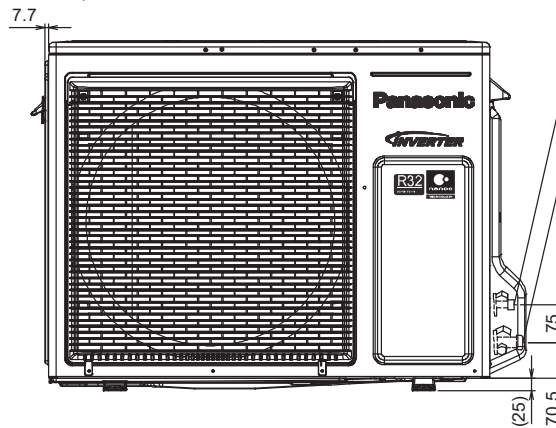

<Mặt bên>

