

MINI CASSETTE

Model No.
CS-S12MB4ZW
CS-S18MB4ZW
CS-S24MB4ZW



TECHNICAL FOCUS

- 4-Way Airflow System
- LCD Wireless Remote Controller
- Random Auto Restart
- Removable Washable Panel
- 24 Hours Real On Off Timer
- Dew Prevention Control
- Anti Freezing Control



Dimensions

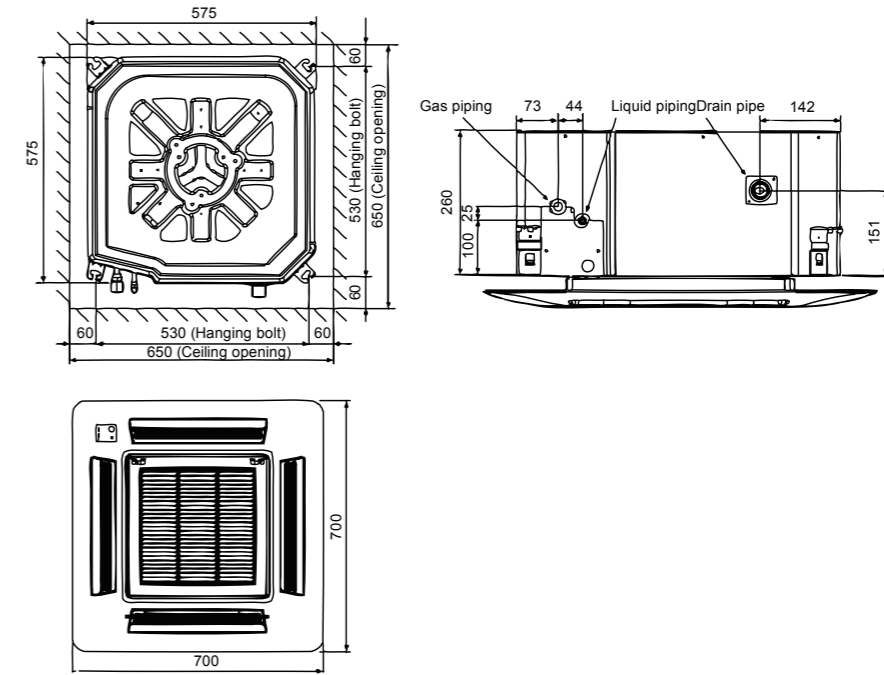

Accessories

Panel



CZ-BT20EW

Selectable Remote Controller



A wireless remote controller is in the same package with the indoor unit.

When raising the drain head above the unit

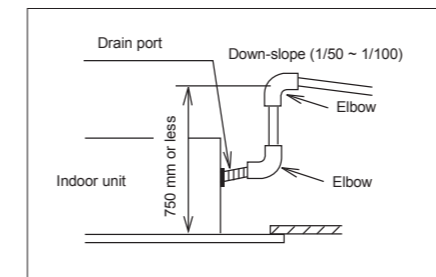

Required space for installation

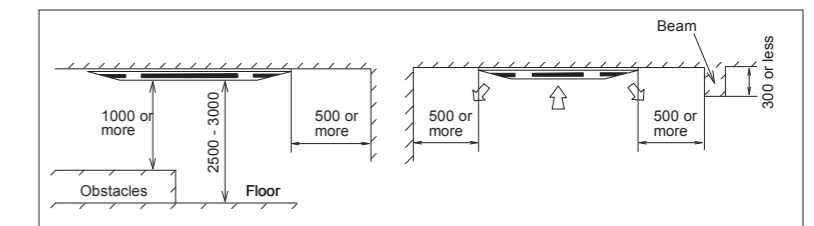

unit: mm

Capacity [Btu/h]		11,600	16,000	19,400
Power Source	V/Phase Hz	220-240 V, 1Ø Phase - 50 Hz		
Indoor		CS-S12MB4ZW	CS-S18MB4ZW	CS-S24MB4ZW
Outdoor		CU-S12MBZ	CU-S18MBZ	CU-S24MBZ
Panel		CB-BT20EW-1	CB-BT20EW-1	CB-BT20EW-1
Cooling Capacity: Rated (Min-Max)	kW	3.40 [0.93-4.40]	4.70 [0.98-5.60]	5.70 [0.98-6.60]
	Btu/h	11,600 [3,170-15,000]	16,000 [3,340-19,100]	19,400 [3,340-22,500]
Current: Rated	A	4.8-4.5	6.3-5.9	8.5-7.9
Power Input: Rated (Min-Max)	kW	0.98 [0.26-1.33]	1.34 [0.27-1.65]	1.82 [0.30-2.15]
	W/W	3.47	3.51	3.13
COP / EER	Btu/hW	11.84	11.94	10.66
Indoor Unit				
Air Volume	m ³ /min	10.5	11.3	12.8
Sound Pressure Level* [Hi/L0/Q-L0]	dB [A]	34 / 26 / 23	38 / 28 / 25	41 / 33 / 30
Dimension	Indoor [H×W×D]	mm	260 × 575 × 575	260 × 575 × 575
	Panel [H×W×D]	mm	51 × 700 × 700	51 × 700 × 700
Net Weight	Indoor	kg	18.0	18.0
	Panel	kg	2.5	2.5
Outdoor Unit				
Sound Pressure Level [Hi]	dB [A]	47-48	49-50	49-50
Dimension	Outdoor [H×W×D]	mm	540 × 780 × 289	695 × 875 × 320
Net Weight		kg	31.0	44.0
Piping Connection	Gas Pipe	mm (inch)	12.70 [1/2]	12.70 [1/2]
	Liquid Pipe	mm (inch)	6.35 [1/4]	6.35 [1/4]
Pipe Length	Min-Max	m	3.0-15.0	3.0-20.0
Elevation Difference		m	15.0	15.0
Maximum Chargeless Length	Max	m	7.5	10.0
Additional Gas		g/m	15	20
Operating Range, Outdoor	Min-Max	°C	16-43	16-43

Dimensions (CU-S12MBZ) 1-phase

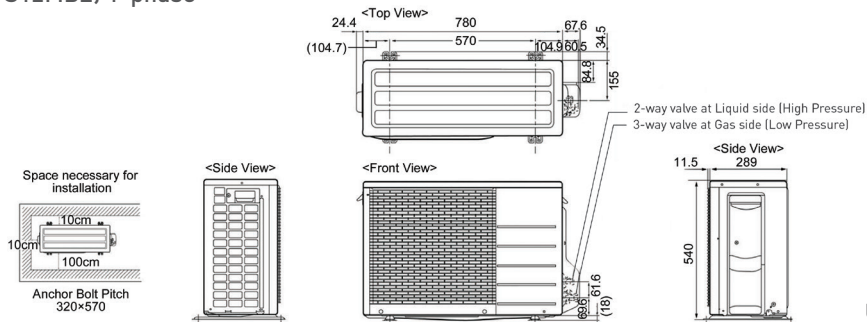

Dimensions (CU-S18MBZ / CU-S24MBZ) 1-phase

