

INSTALLATION AND OPERATING INSTRUCTIONS

Energy Recovery Ventilator

Model No. FV-80ZY1 FV-1KZY1
FV-1HZY1 FV-2KZY1

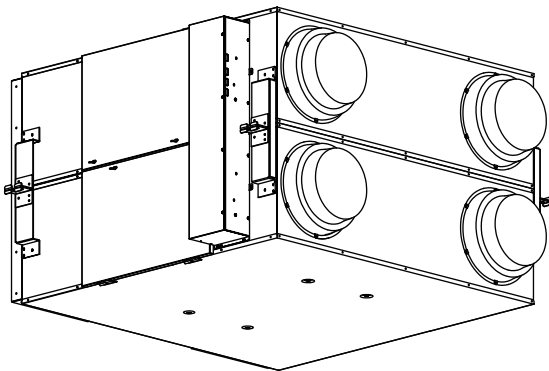
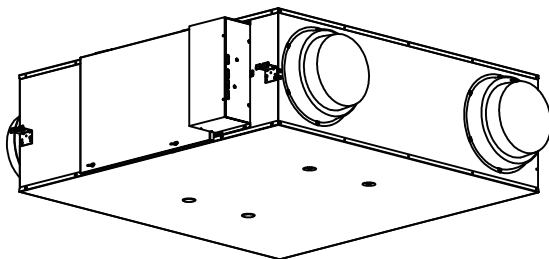

CONTENTS:

SAFETY INSTRUCTIONS	2
INSTALLATION INSTRUCTIONS	2~5
INSTALLATION AND OPERATING REQUIREMENTS	5~6
PRODUCT FEATURES	6
SUPPLIED ACCESSORIES	7
PART NAMES AND DIMENSIONS	7~8
WORK BEFORE INSTALLATION	9
HOW TO INSTALL	10~15
TEST RUN	15~16
USE AND MAINTENANCE INSTRUCTIONS ...	16~17
MAINTENANCE	18~20
WIRING DIAGRAM	21~22
TROUBLESHOOTING	22
SPECIFICATIONS	23
OPTIONAL ACCESSORIES	24

Thank you for purchasing this Panasonic product.

Please read these instructions carefully before attempting to install, operate or service the Panasonic product. Please carefully read "INSTALLATION INSTRUCTIONS" (P.2~5) of this instructions before installation. Failure to comply with instructions could result in personal injury or property damage. Please explain to users how to operate and maintain the product after installation, and this booklet should be presented to users. Please carefully read "USE AND MAINTENANCE INSTRUCTIONS" (P.16~17) of this instructions before operation.

Please retain this booklet for future reference.

SAFETY INSTRUCTIONS

Please observe strictly

- Disconnect power supply before maintenance.
- This product is not intended for use by persons (including children) with reduced physical, sensory or mental capabilities, or lack of experience and knowledge, unless they have been given supervision or instruction concerning use of the product by a person responsible for the safety. Children should be supervised to ensure that they do not play with the product.
- If the supply cord is damaged, it must be replaced by manufacturer or its service agent or a similarly qualified person in order to avoid a hazard.

The following instructions should be strictly observed in order to prevent injury to the users and other people, or damage to property.

- The following symbols differentiate the levels of danger or injury that may result if the product is not used correctly as instructed.



WARNING

This indication means: Must be treated seriously that this may result in death or serious injury.



CAUTION

This indication means: Must be treated seriously that this may result in injury or physical damage.

- Types of instructions that should be observed have been classified and described by the following pictorial symbols.



This symbol indicates the item is "CAUTION".



This symbol indicates the item is "PROHIBITED" to do.



This symbol indicates the "COMPULSORY" item that must be followed without failure.

INSTALLATION INSTRUCTIONS



WARNING

Do not disassemble this product for repair or reconstruction.



Otherwise, it may cause the fire, electric shock and injury. Please contact the dealer for repair.

Do not install the product with a method which is not approved in the instructions.



Improper practice of installation could cause an electric shock or a fire.

The product must be grounded.



Otherwise, it may cause electric shock when there is a fault or electric leakage.

The product must be installed by professionals or trained personnel with equivalent expertise and skills according to the national wiring rules.



Otherwise, electric leakage, electric shock or a fire may be caused due to incorrect wiring, twisted wiring or wire clamping.

Do not operate the product other than the rated voltage.



Otherwise, it may cause damages to the product or a risk of fire.

INSTALLATION INSTRUCTIONS

WARNING

Please install a suitable all-pole switch with a contact separation of more than 3 mm (site supplied). Please use the switch with rated current above 10 A.

 Otherwise, it may cause a short circuit, thus resulting in a fire.

Do not install the outside air inlet in places where combustible gases or any other exhaust gases may enter the product.

 Otherwise, it may cause indoor hypoxia or air pollution, or even result in a fire.

Do not install the product or the room air inlet in places such as machinery plants, chemical plants or research facilities where harmful gases or gases containing corrosive ingredients, including acid, alkali, organic solvent and paint, are generated.

 Otherwise, it may cause poisoning, or result in a fire due to internal corrosion or deterioration of the product.

Avoid the back-flow of gas into the room from an open flue with flammable gas or other open-fire appliances.

 Otherwise, it may cause fire.

Do not install the product or the room air inlet in places with heavy cooking oil fumes.

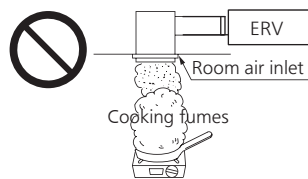

Otherwise, it may cause odor pollution. The filter or the heat exchange core cannot be used after it is clogged with oil; otherwise, it may cause a fire.

Do not install in location where the product may be exposed to the combustible gas leakage.

 In case gas accumulates around the product, it may cause the fire.

CAUTION

Do fix this product securely.

 Otherwise, it may fall off and cause personal injury.

Components must be installed securely.

 Otherwise, it may fall off and cause personal injury.

Owing to the different installation position for special purpose circuit breaker, please install an anti-creep circuit breaker.

 It may cause electric leakage if anti-creep circuit breaker is not installed.

Do not install the outside air inlet close to a pollution source.

 Otherwise, it may pollute the indoor air.

The special-purpose or dedicated parts, such as mounting fixtures, must be used if such parts are provided (include the accessories).

 Otherwise, it may fall off to cause personal injury.

Please wear gloves and other protective tools.

 Otherwise, it may cause personal injury.

INSTALLATION INSTRUCTIONS



CAUTION

Do not operate together with open-burning appliance (e.g. gas or oil furnaces).

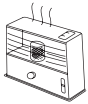

Otherwise, it may cause carbon monoxide poisoning. Please use a dedicated ventilator.

Please pay attention to the rotation of impeller caused by backdraft air in air duct.



Although the power is shut off, part rotation may occur, resulting in injury.

Be sure to have the product transported and installed by two or more engineers. Please pay attention to the center of gravity and the weight when moving the product.



Dropping may cause injury.

When drilling or cutting the wall or ceiling, do not damage the wires or ducts in the wall.



Otherwise, it may cause a safety risk.

Do not install the product or the room air inlet in places where high-temperature or high-humidity air may enter the product.

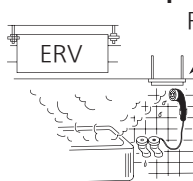

Room air inlet
Otherwise, dew may be generated inside the product, causing electric shock or water dripping and thus leading to property damage.

Install the outside air inlet at a position where the exhaust air from the product does not directly flow back.



Otherwise, it may cause indoor air pollution and thus may harm health.

The building structure and fixings which are used to install the product must have sufficient strength to support more than 5 times the weight of the product. They must be reinforced if their strength is insufficient.

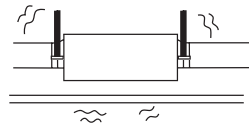

Otherwise, it may fall off causing personal injury.

Do not twist the product or apply excessive load to the product during construction.



Dropping may cause injury.

Do not insert fingers or sticks into the product air inlet, or air outlet.



Otherwise, the operation of rotation part will cause the personal injury.

Do not install the product or the room air inlet in high-temperature places (where the ambient temperature exceeds 40 °C) or places in direct contact with heat sources.

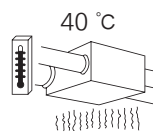

Usage in high temperature conditions may cause distortion of filter, heat exchange core, or motor burn-out.

Please install anti-bird netting or similar prevention in pipe hood.



Please remove the abnormalities such as bird nests, otherwise it may cause a lack of oxygen in room.

Do not install the product in dusty or dirty locations.



Otherwise, the filter may be clogged with dust or dirt, and thus the outside air inlet may be blocked or shorten the service life of the filter.

INSTALLATION INSTRUCTIONS



CAUTION

Heat-insulate the outdoor duct (including the indoor side, if necessary) to prevent condensation.



If heat insulation is not adequate, condensate may enter the property causing damage.

When the ceiling is subject to high temperature and high humidity, install a ventilator on the ceiling.



Otherwise, it may cause fire and electric leakage.

Do not install the product in an environment where the indoor temperature is significantly lower than the outdoor temperature.



Otherwise, it may cause condensation, electric shock and malfunction.

INSTALLATION AND OPERATING REQUIREMENTS

■ It must operate with filter.

If filter is not used, heat exchange core will be clogged with dirt and dust. The performance of the product will be affected, and the product may no longer operate.

■ Turn on/off the switch correctly.

If repeatedly turning on or off the switch, it will affect the product operations and damage the relay in the product.

■ Do not use the 「Normal ventilation」 during winter.

Condensation will be produced inside the supply air outlet if operation mode 「Normal ventilation」 is used in a heated room during winter.

■ To avoid accidents, the product shall be installed at least 2.3 m above the ground level.

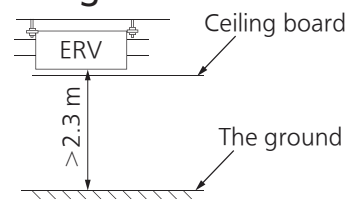

■ Do not place pets and plants directly exposed to supply air outlet or exhaust air outlet.

Otherwise, it may cause discomfort to pets and dry out plants.

■ Please avoid the following duct installation.

(1) Excessive bending

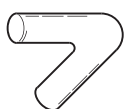

(2) Multiple bends.



(3) Reduction in diameter of connecting duct

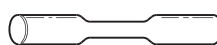

It may cause the unexpected operation.

INSTALLATION AND OPERATING REQUIREMENTS

Using conditions & Precautions

■ Using condition

- Outdoor air condition
Temperature range $-10\text{ }^{\circ}\text{C}\sim 40\text{ }^{\circ}\text{C}$
relative humidity 85% or less.
- Indoor air condition
Temperature range $-10\text{ }^{\circ}\text{C}\sim 40\text{ }^{\circ}\text{C}$
relative humidity 85% or less.
- Installation requirements:
same as the indoor air conditions.
The indoor air here refers to the air in a living room equipped with an air conditioner.
Do not use this product in refrigerated warehouses or any other places where the temperature changes sharply even if the temperature falls within the above temperature range.

For example: Indoor air conditions

During cooling period: temperature $27\text{ }^{\circ}\text{C}$
relative humidity 50%

During heating period: temperature $20\text{ }^{\circ}\text{C}$
relative humidity 40%

■ Be careful of frost and dew

As shown in the following figure, it is supposed that a high temperature absorbing air condition A and a low temperature absorbing air condition B are plotted on the line figure, then a high temperature air A is exchanged by the unit and Point C represent the trend of saturation curve. In this case, it will cause dew or frost inside the unit. To avoid this, you are required to heat low temperature air from B to B' to get C' below saturation curve before entering the unit.

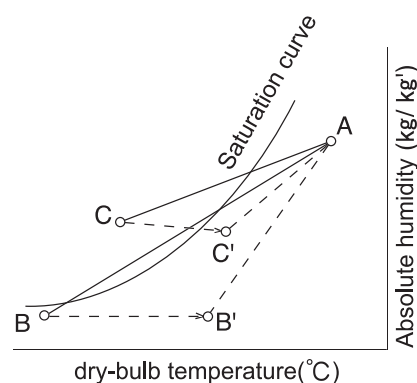

PRODUCT FEATURES

1. Energy saving ventilation

Thanks to efficient recovery of thermal energy lost during Ventilation (load incurred by outside air), you can save an air-conditioning fee.

2. Facility saving

Thanks to a drastic reduction of load incurred by outside air, you can make air-conditioners more compact in parallel with the recovery of thermal energy.

3. Humidity adjusting effect

In a cooling mode, a highly humid open-air is brought near to a dehumidified room atmosphere and then supplied. In a heating mode, a room humidity is transferred to the dry outside air and then supplied.

4. Comfortable and consistent ventilation

Ventilation is available with least possible fluctuation of a room temperature. Since exhaust and air intake are performed simultaneously, a stable ventilation is possible even in a highly airtight room.

5. Sound shield effect

The ducts of the unit and the heat exchange core are characteristic of sound shield effect. Thus, it prevents an outside noise from coming in the unit and also sound inside the unit from going out, so that the office and store environment can be preserved.

6. RS485 central control



The energy recovery ventilator is connected to a remote control (optional) with RS485 function for central control management by BMS or similar.

7. Outdoor filters

Outdoor filters conform to MERV 16 class of ASHRAE 52.2 standard.

SUPPLIED ACCESSORIES

The following accessories are provided with the product in the package. When you unpack, check if the accessories are all included. If not, please contact your dealer.

No.	Drawing	Name and Purpose	Qty
①		Installation and operating instructions	1
②		Model label	1

PART NAMES AND DIMENSIONS

■FV-80ZY1, FV-1KZY1

Unit: mm

Model No.	A	B	C	D	E	F	G	H	J	K	L	M	N	Applicable duct diameter
FV-80ZY1	1224	1060	1148	1004	404	202	122	φ245	φ300	633	185.5	121	168	φ250
FV-1KZY1	1224	1287	1148	1231	404	202	122	φ245	φ300	860	185.5	121	168	φ250

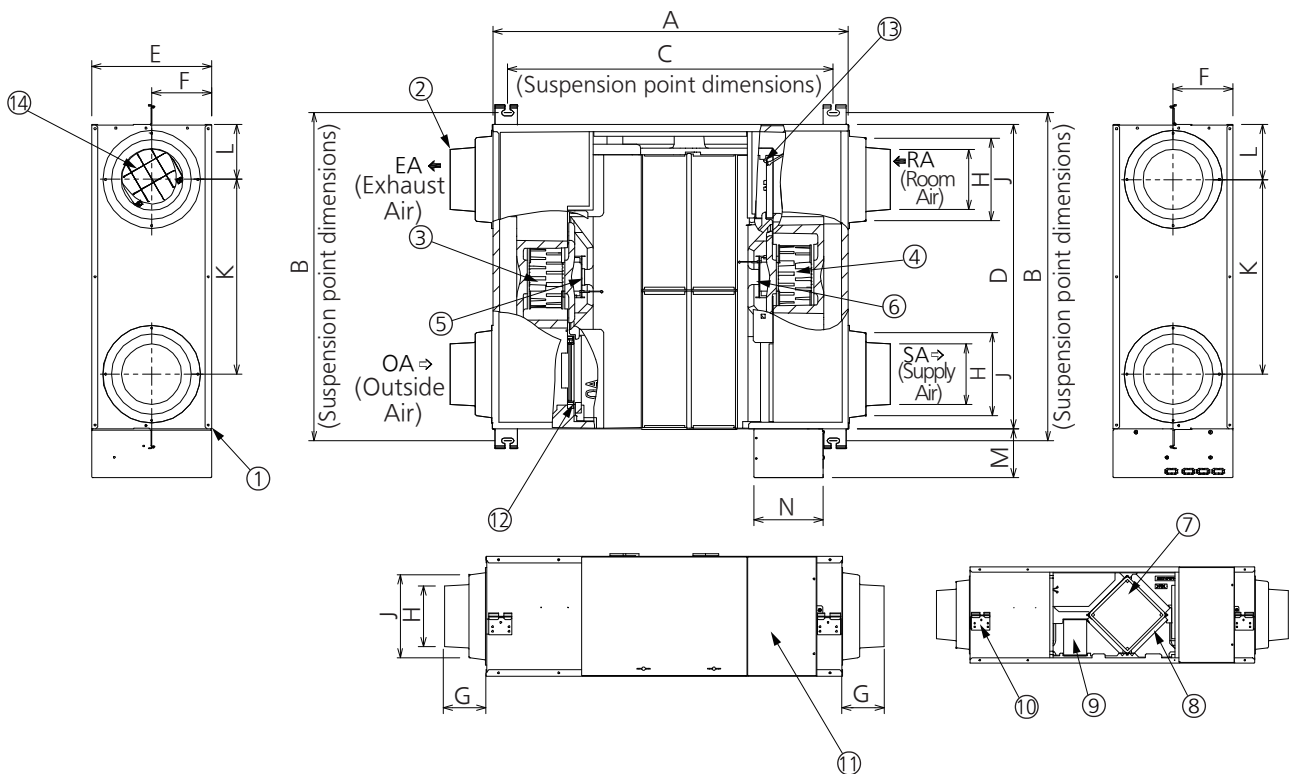

No.	Part name	Qty	No.	Part name	Qty	No.	Part name	Qty
①	Frame	1	⑥	SA motor	1	⑪	Electrical equipment box	1
②	Adapter	4	⑦	Heat exchange core	2	⑫	OA damper motor	1
③	EA impeller	1	⑧	RA filter	1	⑬	RA damper motor	1
④	SA impeller	1	⑨	Outdoor filter	2	⑭	EA backdraft damper	1
⑤	EA motor	1	⑩	Suspension bracket	4			

PART NAMES AND DIMENSIONS

■FV-1HZY1, FV-2KZY1

Unit: mm

Model No.	A	B	C	D	E	F	G	H	J	K	L	M	N	Applicable duct diameter
FV-1HZY1	1224	1141	1127	1004	808	202	122	Φ245	Φ300	663	185.5	121	168	Φ250
FV-2KZY1	1224	1368	1127	1231	808	202	122	Φ245	Φ300	860	185.5	121	168	Φ250

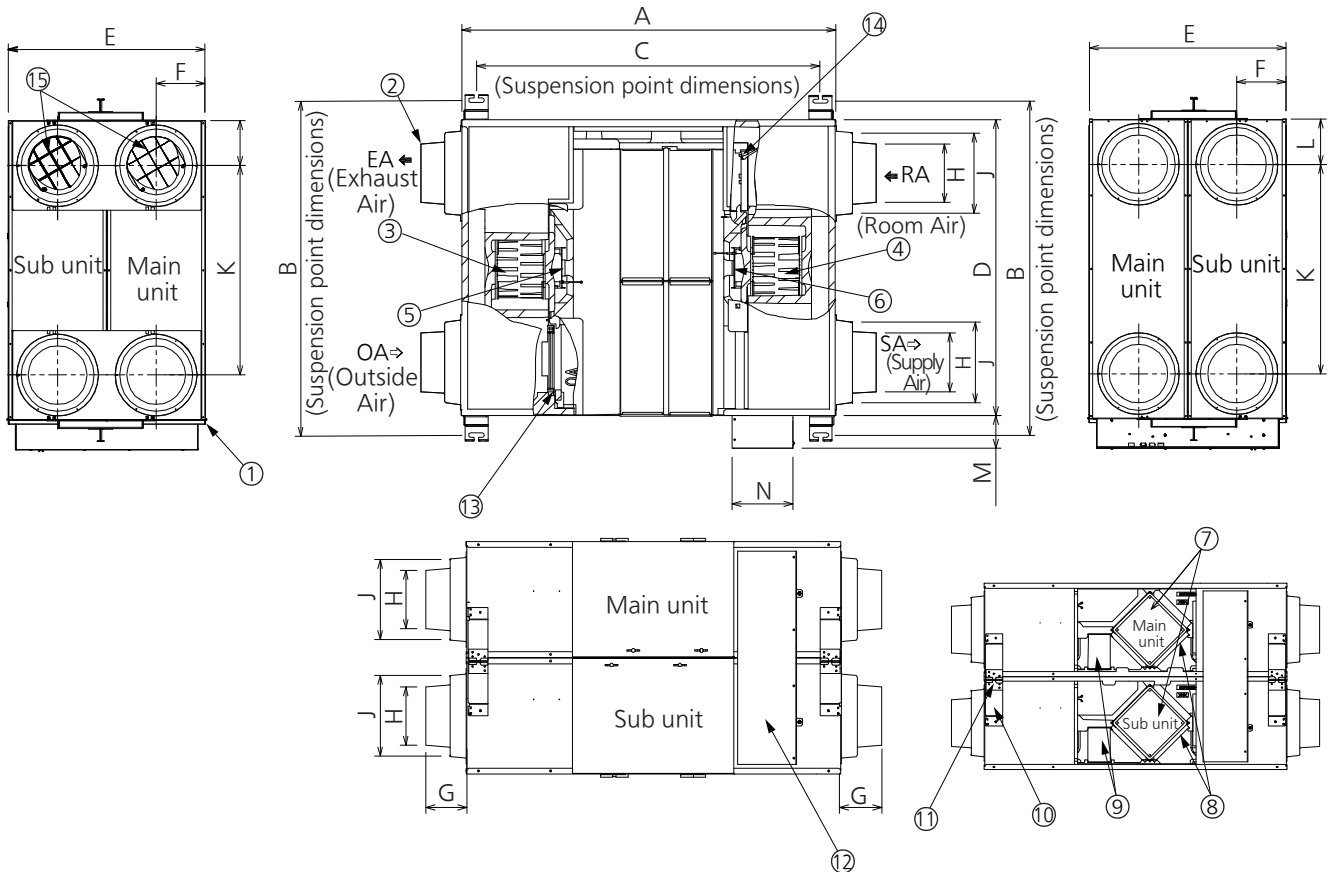

No.	Part name	Qty	No.	Part name	Qty	No.	Part name	Qty
①	Frame	1	⑥	SA motor	2	⑪	Suspension bracket 2	8
②	Adapter	8	⑦	Heat exchange core	4	⑫	Electrical equipment box	1
③	EA impeller	2	⑧	RA filter	2	⑬	OA damper motor	2
④	SA impeller	2	⑨	Outdoor filter	4	⑭	RA damper motor	2
⑤	EA motor	2	⑩	Suspension bracket 1	4	⑮	EA backdraft damper	2

WORK BEFORE INSTALLATION

①Please ensure a safe distance (Figure 1)

- (1)Ensure the distance between the underside of the unit and ceiling board is over 25 mm.
- (2)Ensure the distance between the top of the unit and the mounting face of supports is over 25 mm.

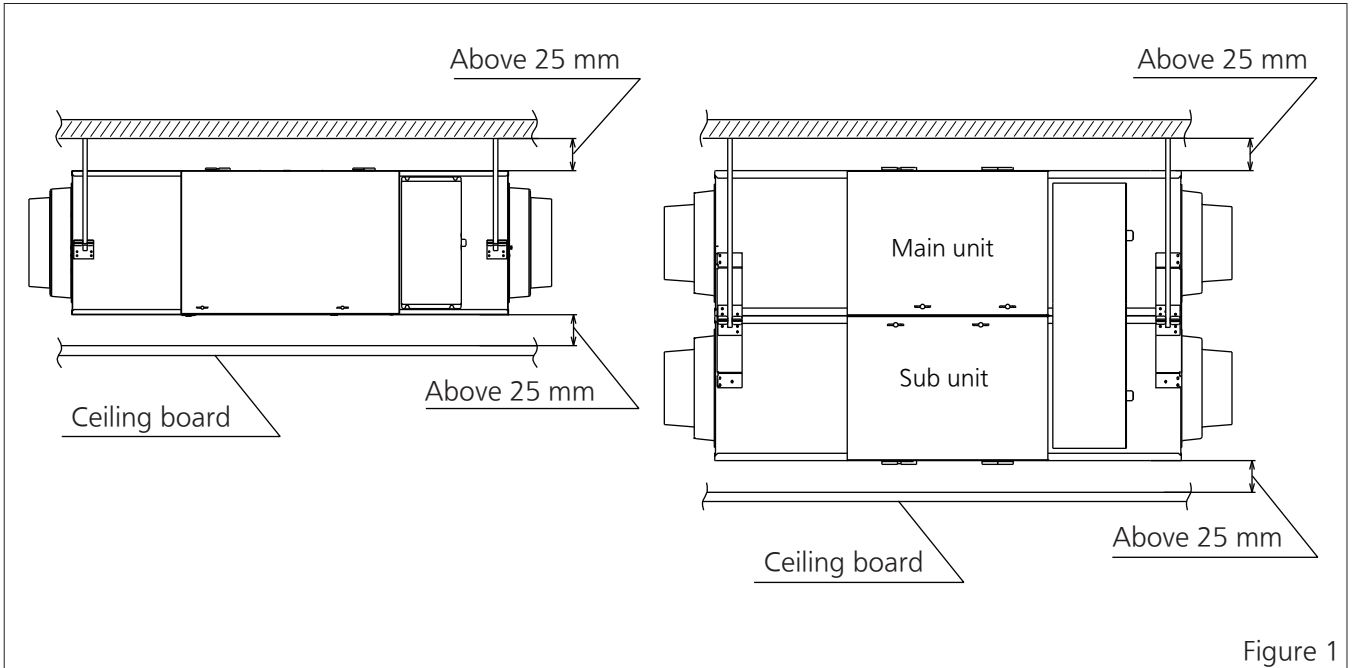

Figure 1

②Set the inspection opening (Figure 2)

- (1)No other devices should be set inside the double dot scribing area, which is reserved for maintenance.
- (2)During reverse installation, the position of the inspection opening should also meet the dimensional relationship shown in Figure 2.

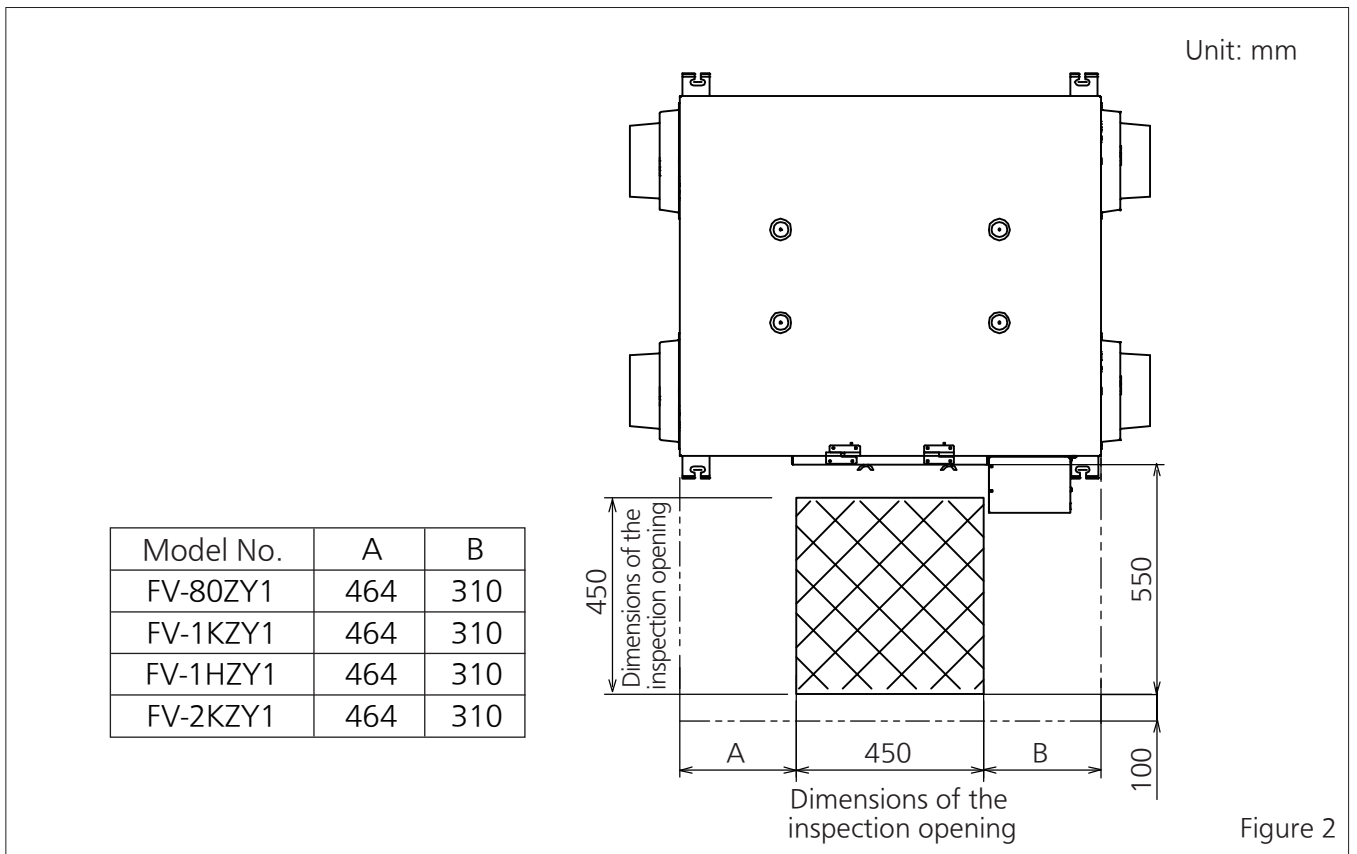
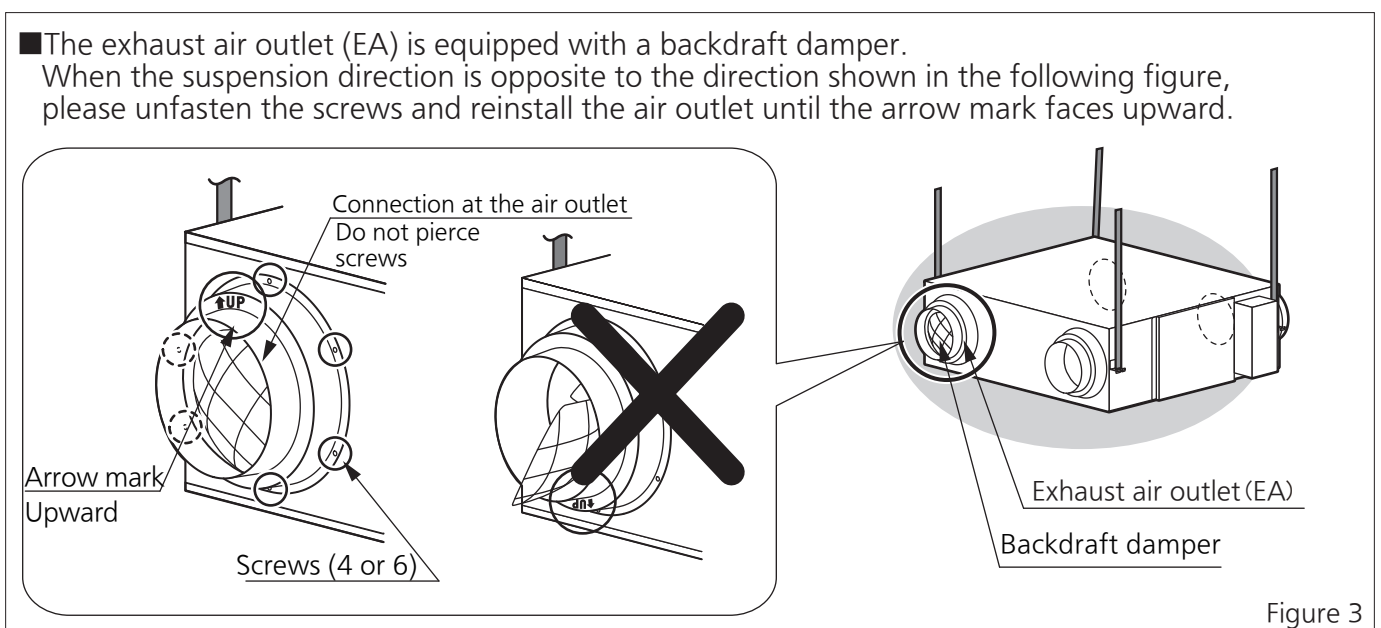
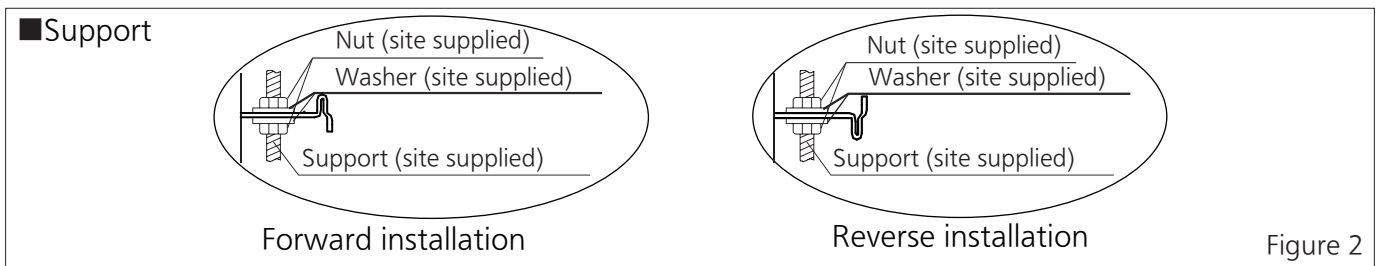
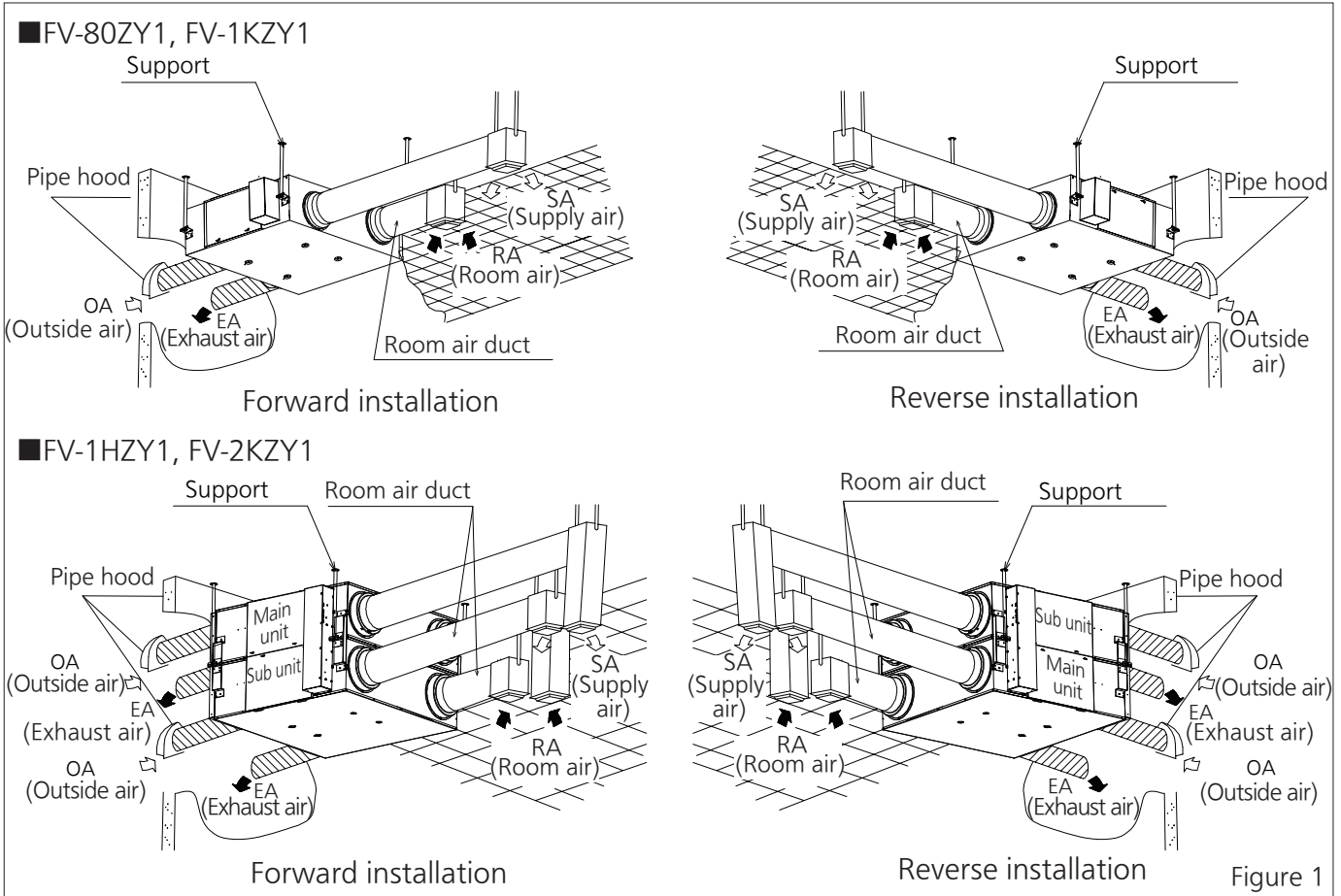

Figure 2

HOW TO INSTALL

■ Installation of energy recovery ventilator

① Installation diagram (Figure 1、Figure 2、Figure 3)



HOW TO INSTALL

- ② Positioning and installation of supports (Figure 1)
- (1) Please set the supports according to the suspension brackets of the energy recovery ventilator. (site supplied: M10-M12)
- (2) Install the suspension brackets (4) of the energy recovery ventilator to the supports (site supplied).



CAUTION

Be sure to firmly install the supports, washers and nuts.



Otherwise, the product may fall off, and cause injury.

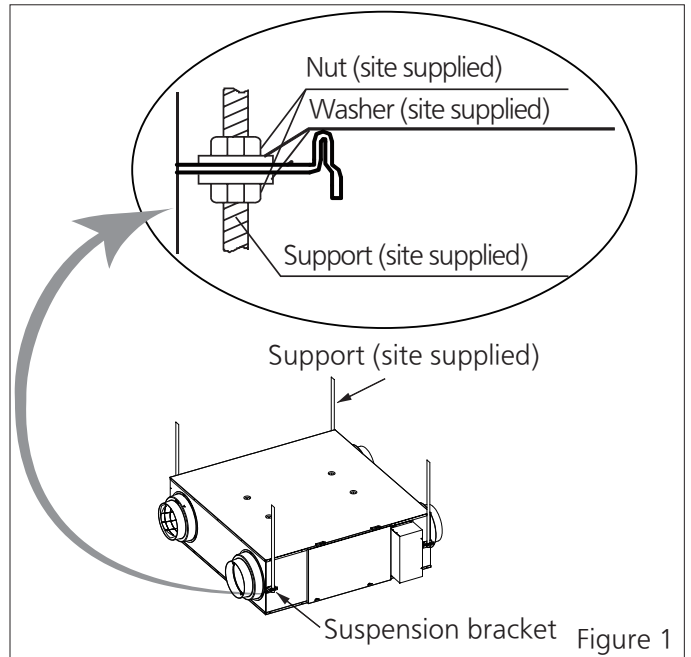

Suspension bracket Figure 1

■ Duct Installation

- ① When installing the ducts (2 or 4) connected to the outdoor side, tilt the ducts to the outside (at a gradient of 1/100 to 1/50) to prevent rainwater ingress. (Figure 2)

Notice

Suspend the ducts (site supplied) on the ceiling with support parts (site supplied) to prevent external force from being applied to the energy recovery ventilator.

- ② Seal adapter joint and duct (site supplied) with aluminum tape (site supplied) or seal tape (site supplied) to avoid air leakage.
- ③ Wrap insulation materials (site supplied) on the outside of the junction between the adapter and the duct. (Figure 3)
- ④ Insulate the ducts (2 or 4) directly exposed to outside. (Figure 4)
(Suggested material: glass wool, thickness 25 mm)
- ⑤ Install pipe hood outdoors.
(Please purchase a pipe hood or vent cap separately according to the pipe size.)

Notice

For the FV-1HZY1 and FV-2KZY1 models, connect the ducts to the main unit and sub unit separately.

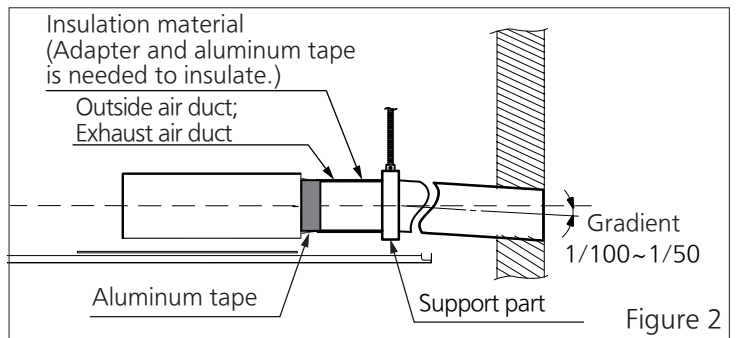

Figure 2

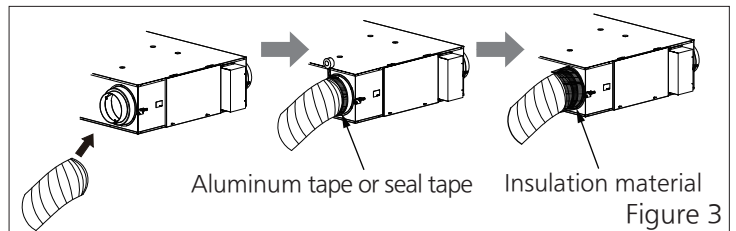

Figure 3

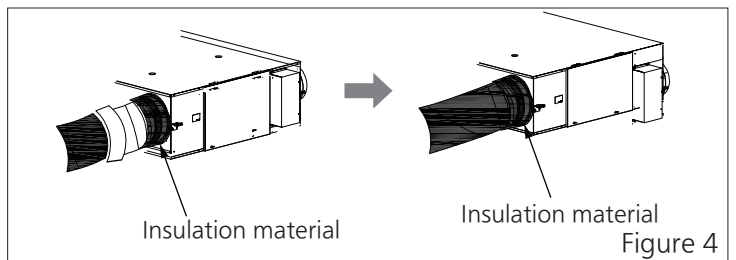

Figure 4



WARNING

When a metal pipe is used, if the pipe passes through a wall with a metal structure inside, prevent the metal pipe contacting with the metal structure.



Otherwise, it may cause electric shock or fire.



CAUTION

When the product is used in an environment exposed to many insects or with street lights around the outside air inlet and exhaust air outlet and where insects are easily attracted, pipe hood equipped with fly nets should be used with the product. Insects may be sucked into the energy recovery ventilator from pipe hood. Pipe hood cannot completely prevent insects from passing through the window screen.

HOW TO INSTALL

■Wire connection

- ①Strip the power cord. (Figure 1)
Strip the power cord according to the wiring sketch.
If the power cord is stripped, a short circuit or fire may occur.

Notice

- For the remote control (optional) wiring arrangement, please refer to the installation and operating instructions of remote control for more details.

- ②Open the cover of electrical equipment box.
(Figure 2)
 - (1)Remove the screws on the cover of electrical equipment box.
 - (2)Remove the cover of electrical equipment box.
- ③Unfasten the screws on the wire clip that secures the wire.

- ④Unfasten the screws on the terminal block, twist together the copper strands of each core, pass the wires through the corresponding wire plug and wire clip, insert them into the wiring part of the terminal block, and ensure they are all inserted under the washers. (Figure 3)

- ⑤Connect wires at the corresponding positions. (Figure 4 and Figure 5)
 - (1) It is recommended to use the wire (soft wire) with rated voltage 300 V/500 V to link power supply cord with switch as stipulated in 60227 IEC 53.
 - (2) Use 3 core wire containing green/yellow wire, each core wire should have cross section area of 2.5 mm². (Perform wiring according to the local laws and regulations)
 - (3) Use 2 core wire to link the terminal SW1, SW2 with switch, additionally, please use 4 core wire to link the other terminals with switch, each core wire should have cross section area of 2.5 mm². (Perform wiring according to the local laws and regulations)

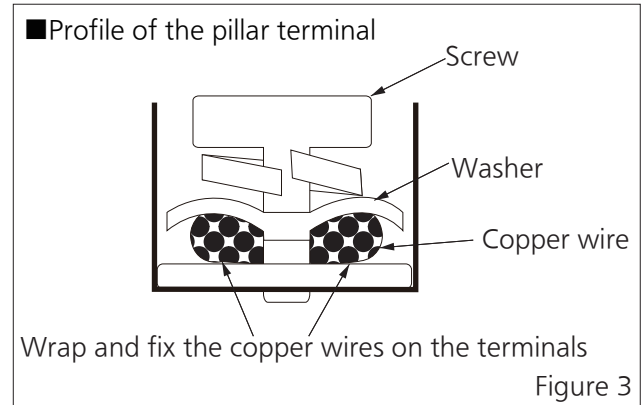
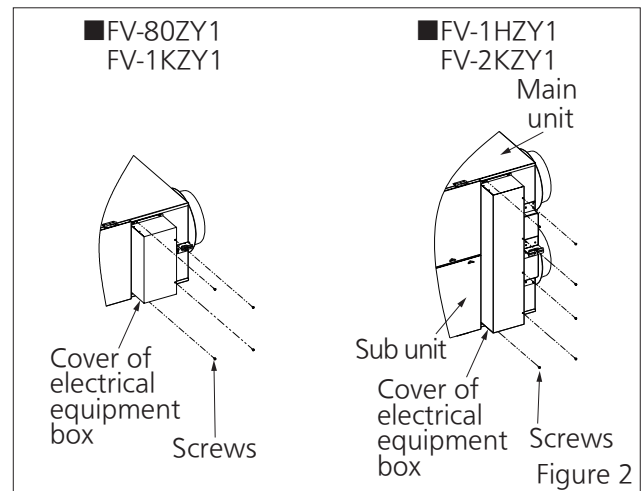
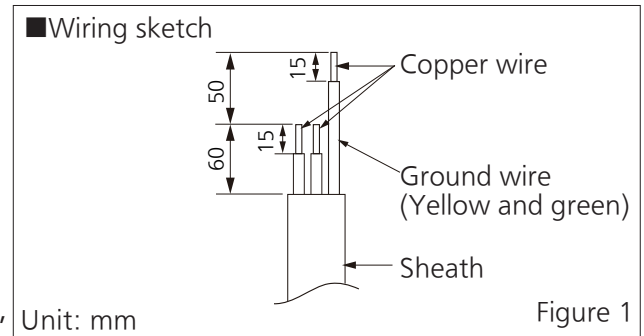

HOW TO INSTALL

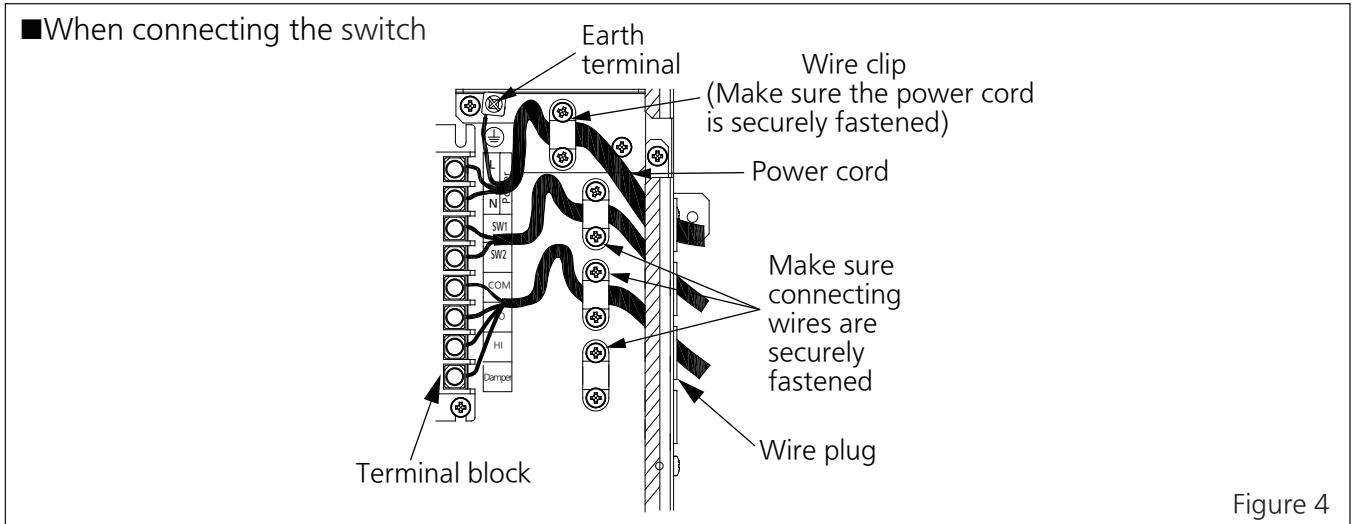

(4) If you need to use the remote control (optional) with RS485 function, please connect the wire according to the wiring diagram in the instructions of the remote control.

Notice

The remote control and the switch cannot be used at the same time.

(5) If utilising the function to interlock with an air conditioner, use a single-core wire with the cross section area of 2.5 mm² to connect the terminal SW2 to HI, as shown in Figure 5; use 2 core wire with the cross section area of 2.5 mm² to connect the terminal SW1, COM to the volt free contact. (Perform wiring according to the local laws and regulations).

Notice

● Do not use the air conditioner function with remote control at the same time.

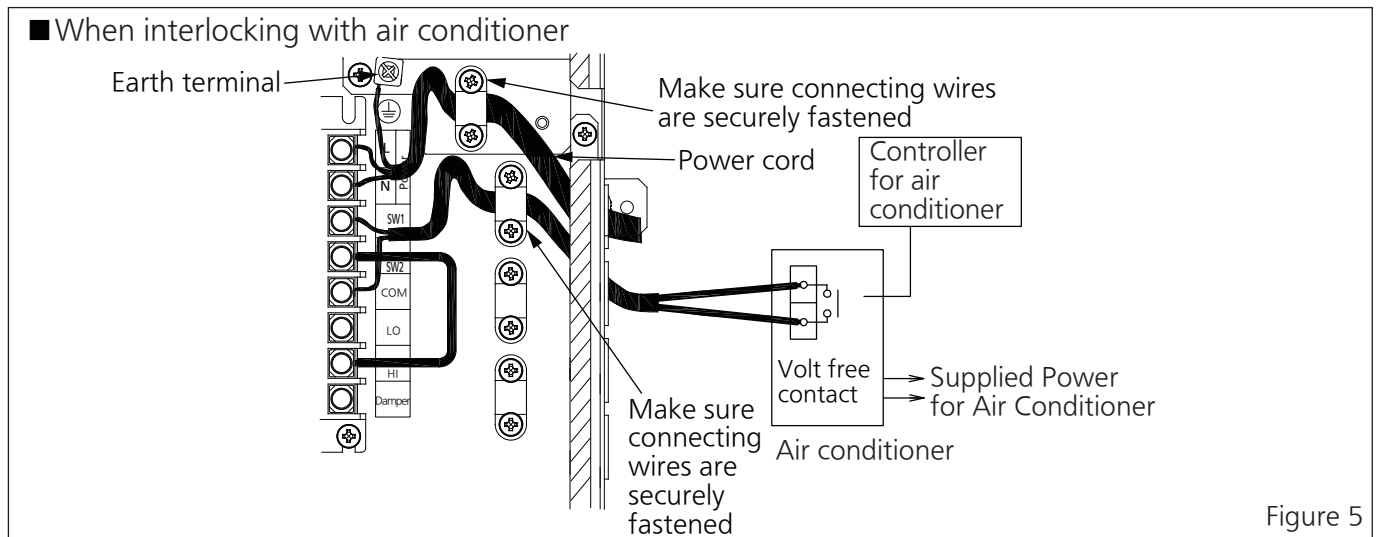

⑥ Fasten the ground wire (yellow and green wire) of the power cord to the earth terminal. (Figure 4 or Figure 5)

Notice

Connect the FV-1HZY1 and FV-2KZY1 models to the power cords, switch, remote control and air conditioners by connecting them to only the terminals on main unit rather than the terminals on sub unit. The methods for connecting the power cord on main unit are consistent with the above steps ① to ⑥.

HOW TO INSTALL

⑦Set the ventilation air volume (Figure 6).

According to the performance (Table 1) of the specific energy recovery ventilator model, select a ventilation air volume suitable for the size of the property by sliding the switch (Figure 6) (Table 2). For the FV-1HZY1 and FV-2KZY1 models, adjust the ventilation air volume of only the main unit.

(Table 1)

Model No.	Notch	External static pressure (Pa)	Air volume (m ³ /h)	Notch	External static pressure (Pa)	Air volume (m ³ /h)
FV-80ZY1	H1	150	800	L1	54	480
	H2	122	720	L2	44	432
	H3	96	640	L3	34.5	384
	H4	74	560	L4	26.5	336
FV-1KZY1	H1	150	1000	L1	54	600
	H2	122	900	L2	44	540
	H3	96	800	L3	34.5	480
	H4	74	700	L4	26.5	420
FV-1HZY1	H1	130	1500	L1	48	900
	H2	107	1350	L2	39	810
	H3	85	1200	L3	31	720
	H4	64	1050	L4	24	630
FV-2KZY1	H1	130	2000	L1	48	1200
	H2	107	1800	L2	39	1080
	H3	85	1600	L3	31	960
	H4	64	1400	L4	24	840

(Table 2)

Air volume setting H (High) or L (Low)	SW1	SW2	SW3	SW4
	SA (supply air) Air volume setting 1	SA (supply air) Air volume setting 2	EA (exhaust air) Air volume setting 1	EA (exhaust air) Air volume setting 2
H1 (L1) (Factory set)	Hi	Hi	Hi	Hi
H2 (L2)	Hi	Lo	Hi	Lo
H3 (L3)	Lo	Hi	Lo	Hi
H4 (L4)	Lo	Lo	Lo	Lo

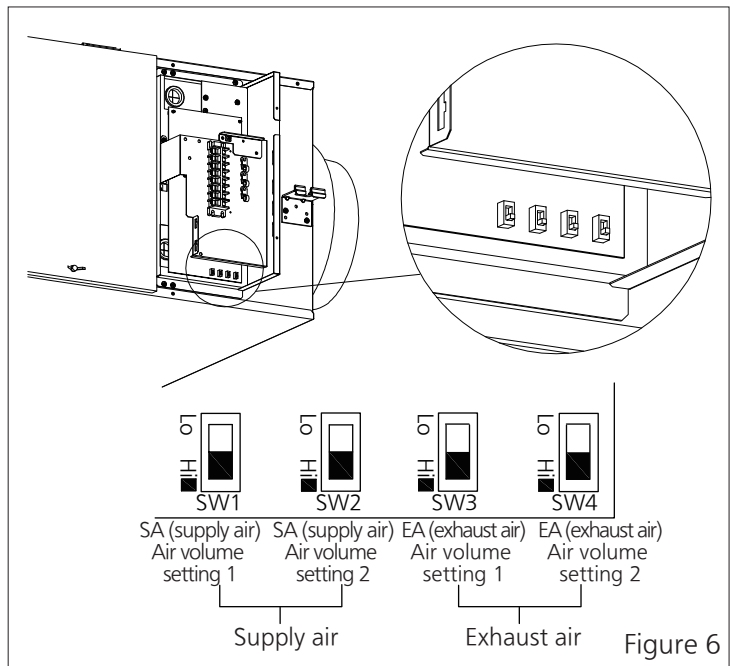

Figure 6

Notice

Select optional accessories by yourself. (Figure 7)

Remote control

Model No.: FV-SWGR1

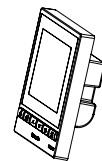
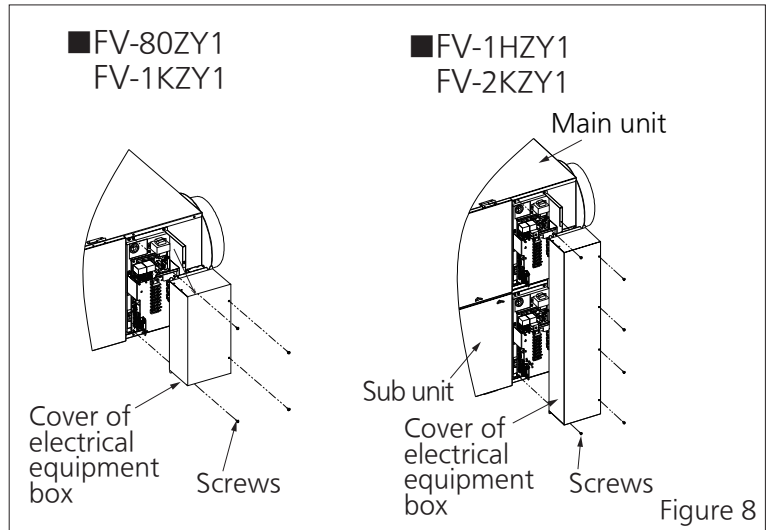

Figure 7

HOW TO INSTALL

- ⑧ Fix the screws removed in step ② (P.12) onto the cover of the electrical equipment box again. (Figure 8)



WARNING

- When fixing the cover of the electrical equipment box, do not press the power cord and connecting wires. Otherwise, the power cord and connecting wires may be damaged.
- Firmly install the power cord and connecting wires and secure the cover of the electrical equipment box to prevent it from tilting. If the cover of the electrical equipment box is not tightly installed, dust and moisture will enter, which may cause fire and electric leakage.

TEST RUN

- After installation, be sure to perform a test run to check that the wiring is correct.
- After confirming the wiring and supply voltage, power on the product and check the indication of the switch and supply air status according to the following table.

Switch/Remote control	ON / OFF	Supply air/Stop
Switching air volume	High/Low	Please check whether the air volume changes with the switching of air volume.
Operating mode shifting	Heat exchange/ Normal ventilation	Please check whether the product changes with the selection of operating mode. (The product stops for a period during shifting)

TEST RUN

- In case of any abnormality, please immediately turn the dedicated circuit breaker to "OFF" and confirm the wiring again.

Situation	Analysis	Description
● The product does not start immediately when the switch or remote control is turned on.	● The OA damper will be turned on first.	● This is normal. Please wait patiently for about 15 seconds.
● The product does not start when the switch or remote control is turned on.	● The power supply is abnormal.	● Check the power supply.
	● Check whether the wiring is correct.	● Check the wiring according to the wiring diagram.
● No air blows out.	● The duct leaks or is blocked.	● Check that the duct is free of leakage and unblocked.
● Noise	● The fixings are loose.	● Check the suspension brackets and ensure that they are not loose.
	● The impeller operates abnormally.	● Please contact the dealer.
	● The connection between the adapter and the duct is abnormal.	● Check that the adapter and the duct are correctly and firmly connected.

- After the test run, the cover of electrical equipment box must be installed properly.
- Please paste the model label near the switch.
The model label is put in a plastic bag with the installation and operating instructions.
Please do not forget to use the label.

USE AND MAINTENANCE INSTRUCTIONS

WARNING

Do not disassemble this product for repair or reconstruction.



Otherwise, it may cause the fire, electric shock and injury. Please contact the dealer for repair.

Do not place combustion appliances in a location where the supply air outlet or exhaust air outlet blows directly.



Otherwise, incomplete combustion may occur causing carbon monoxide poisoning.

Do not allow the product to come in contact with water or pour water on it. (Especially the electrical parts such as the motor and switches)



It may result in short circuit or electric shock.

Please clean the filter regularly.



Too much dirt or dust attached on the filter may cause indoor hypoxia.

When the product is not used for a long time, please shut off the all-pole switch.

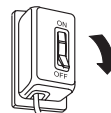

All-pole switch accumulated with too much dust will heat up. It may cause fire.

If the product is no longer required, remove the product.



It might cause injuries if it falls down.

Do not turn on/off the switch with wet hands.



Otherwise, it may cause electric shock.

USE AND MAINTENANCE INSTRUCTIONS



WARNING

Do not turn the switch on/off when there are combustible gas leaks.



Sparks from the switch may cause gas explosion.

Please entrust the dealer or similarly qualified person to repair the product excluding filter maintenance.



Otherwise, it may cause the fire, electric shock and injury.



CAUTION

It is forbidden to operate the product without filters.

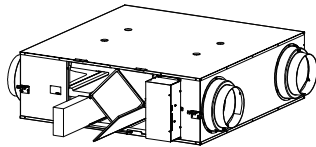

The dirt and dust attached to the heat exchange core will lower its performance, and might leak into the room causing discomfort.

Please consult specialist if the product is used for special purpose.



If the product is used for special purposes such as preservation of food, animals, plants, precision instruments and artwork, it may affect the quality.

Please stop the product immediately and contact the dealer or similarly qualified person to repair it when abnormal operation is found such as noise, vibration, or burnt smell.



Otherwise, it may cause an unexpected accident.

Do not place obstacles near the air intake opening or discharging air opening.



Otherwise, it may cause the injury.

Avoid facing directly into the air outlet (especially when operating).



The dirt may get into your eyes.

Please ensure access equipment is firmly secured when conducting maintenance.



Otherwise, falling may cause physical injury.

Do not use the product near the combustible spray.



Otherwise, it may cause fire.

Please shut off the all-pole switch before maintenance.



Otherwise, it may cause electric shock and injury.

Do not place any object on the product.



When any object leaks, water may enter the product, causing electric shock. When foreign matters enter the product, the impeller may be damaged, causing injury.

Do not incline the product during disassembly.



The accumulated water inside the product may leak into the property. → Please contact authorized dealer for repair.

MAINTENANCE



CAUTION

Please wear gloves during maintenance.



The incisions of sheet metal and resin parts, as well as bulges and sharp corners of the product, may cause injury.

Please pay attention to the identifier of the filter when cleaning or replacing the filter.



Otherwise, the purification efficiency may decrease.

About the service life of the filter

	Cleaning	Replacement
Outdoor filter	About once a month	About once every four to six months
RA filter	About once a month	

Notice

- Clean the product only with neutral detergents. Do not use any of the chemicals or articles as shown, as they may corrode or scratch the product.
- Protect your eyes when cleaning or replacing the filter. Otherwise, dust attached on the filter may enter your eyes. If necessary wear eye protection.
- To prevent the dust adsorbed on the filter from diffusing in the room during cleaning, please clean the filter outdoors or use a vacuum cleaner that can remove PM2.5 particles.

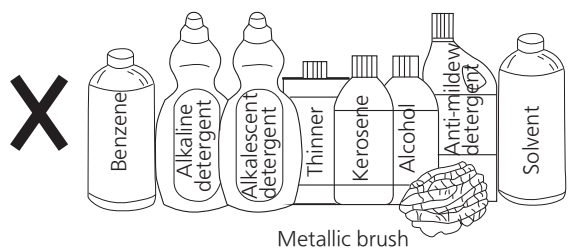

Notice

1. The service life of filter is set based on the operation of 10 hours every day.
2. The air volume and purification efficiency may decrease depending on the operating environment and time. When cleaning the outdoor filters, if you observe that the side to which the arrows of the outdoor filters point become black, please replace the outdoor filters in time.
3. If the product is used in an excellent environment and the concentration of particles with diameter below 2.5 μm is lower than 50 $\mu\text{g}/\text{m}^3$, the deviation of test data may be large due to the accuracy of the test instrument, leading to the decrease of the purification efficiency calculated based on the above test data.
4. If the energy recovery ventilator is used for a long time, the outdoor filters of the energy recovery ventilator will be blocked by dirt and dust, which will cause the decrease of the air exchange volume and air exchange effect, leading to louder noise. Please clean the outdoor filters regularly according to the amount of dirt and dust attached to the filters.
5. If the product is used in a harsh environment (dusty area), the air volume and purification efficiency of the product may decrease drastically. To maintain the performance of the product, please increase the frequency of cleaning or replacing the outdoor filter appropriately.
6. The replacement standard is evaluated according to the independent benchmark of the company. The actual operating environment may be different.
7. The test instrument used by the company is TSI 8530.

MAINTENANCE

Clean and replace the filter

How to maintain and replace the filters

- ① Loosen the butterfly bolts that secure the inspection cover. (Figure 1)
- ② Rotate the inspection cover along the direction indicated by arrow "A". Then slide and remove the inspection cover along the direction indicated by arrow "B". (Figure 2)

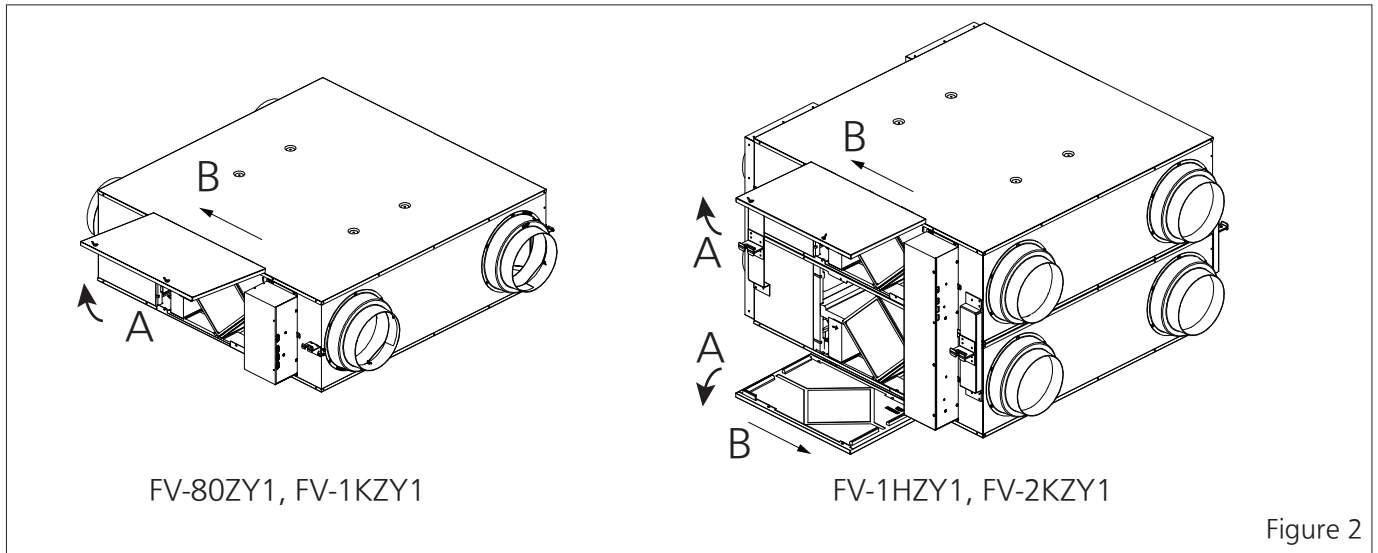
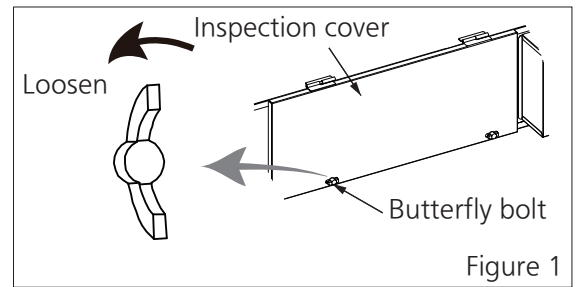

- ③ Remove two (one set) outdoor filters (Figure 3) along the direction indicated by arrow "C". The RA filters can be cleaned at the same time if needed.

Notice

FV-1HZY1/FV-2KZY1 energy recovery ventilator includes four (2 sets) outdoor filters.

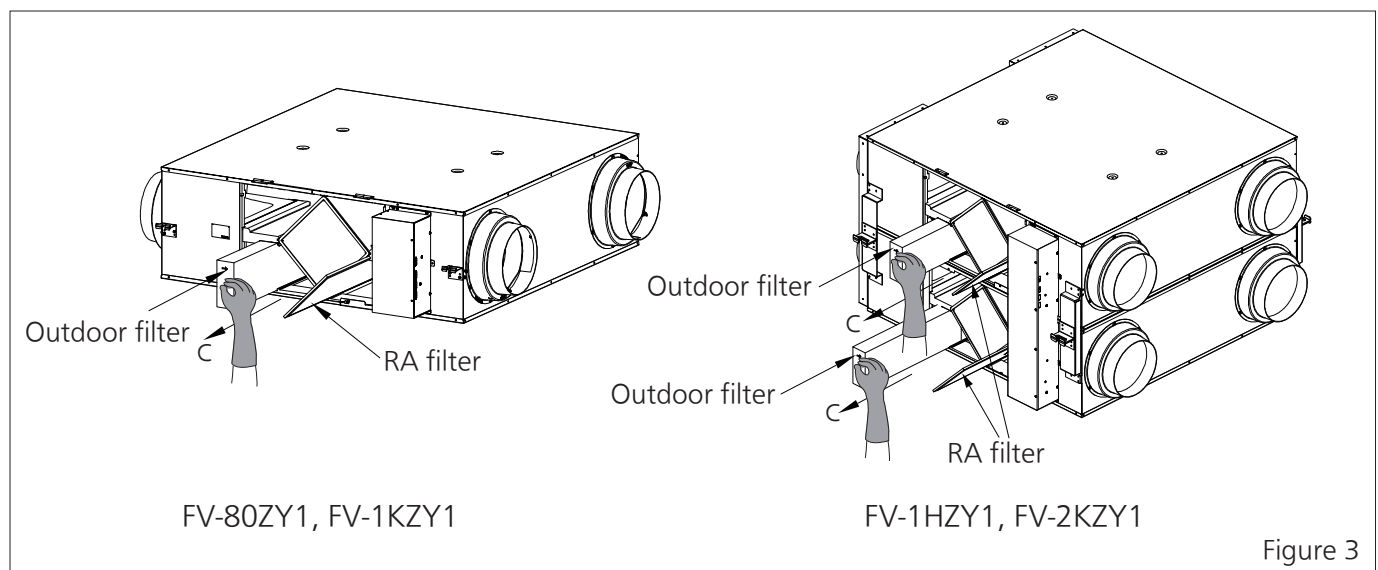

MAINTENANCE

- ④ Use a vacuum cleaner to remove dust or dirt from the outdoor filters or RA filters. This step can be omitted during replacement. (Figure 4)

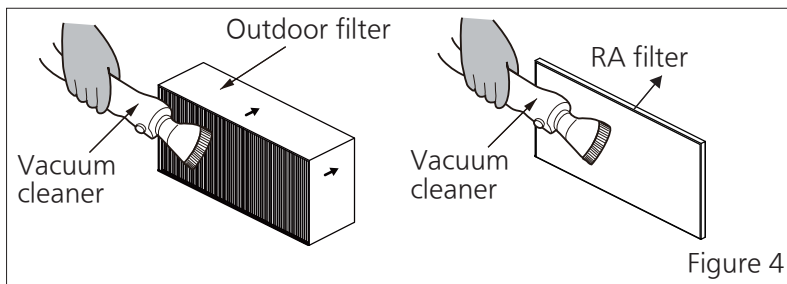

CAUTION

Do not clean the outdoor filters by washing them with water. Otherwise it may damage the outdoor filters and degrade their performance.

- ⑤ Please insert the cleaned or new outdoor filters into the energy recovery ventilator along the guide rail. (Figure 5)

※ The arrow should point to the heat exchange core.

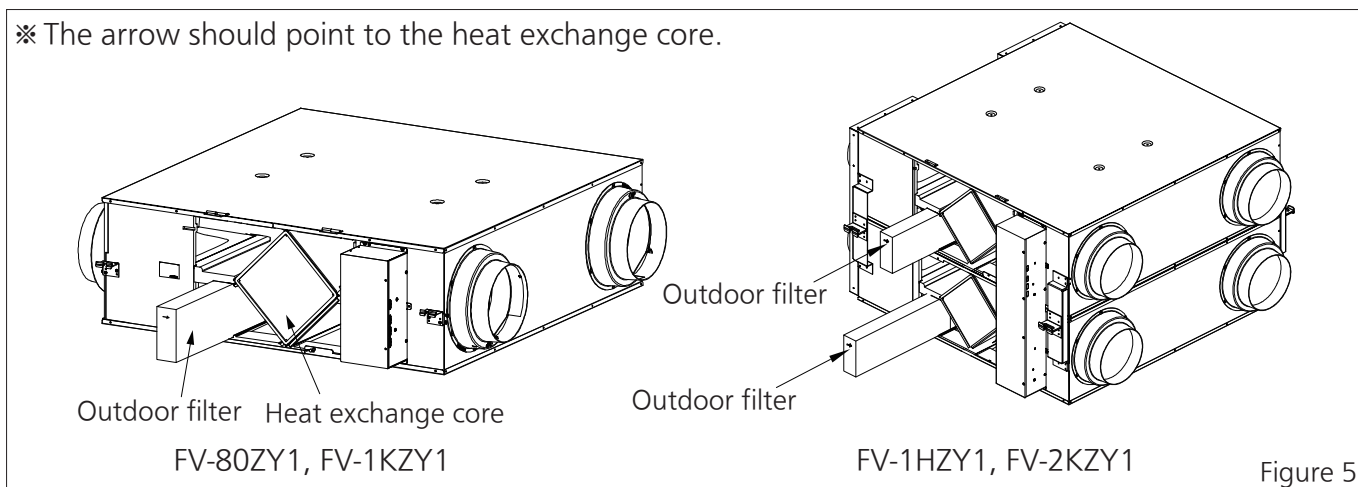

- ⑥ Fix the inspection cover by reversing the steps.



CAUTION

Please pay attention to the installation directions of the filters. Improper installation may reduce the purification efficiency.

WIRING DIAGRAM

Connect wires indicated by dashed lines. Please use the switch with rated current above 10 A.

■ FV-80ZY1, FV-1KZY1

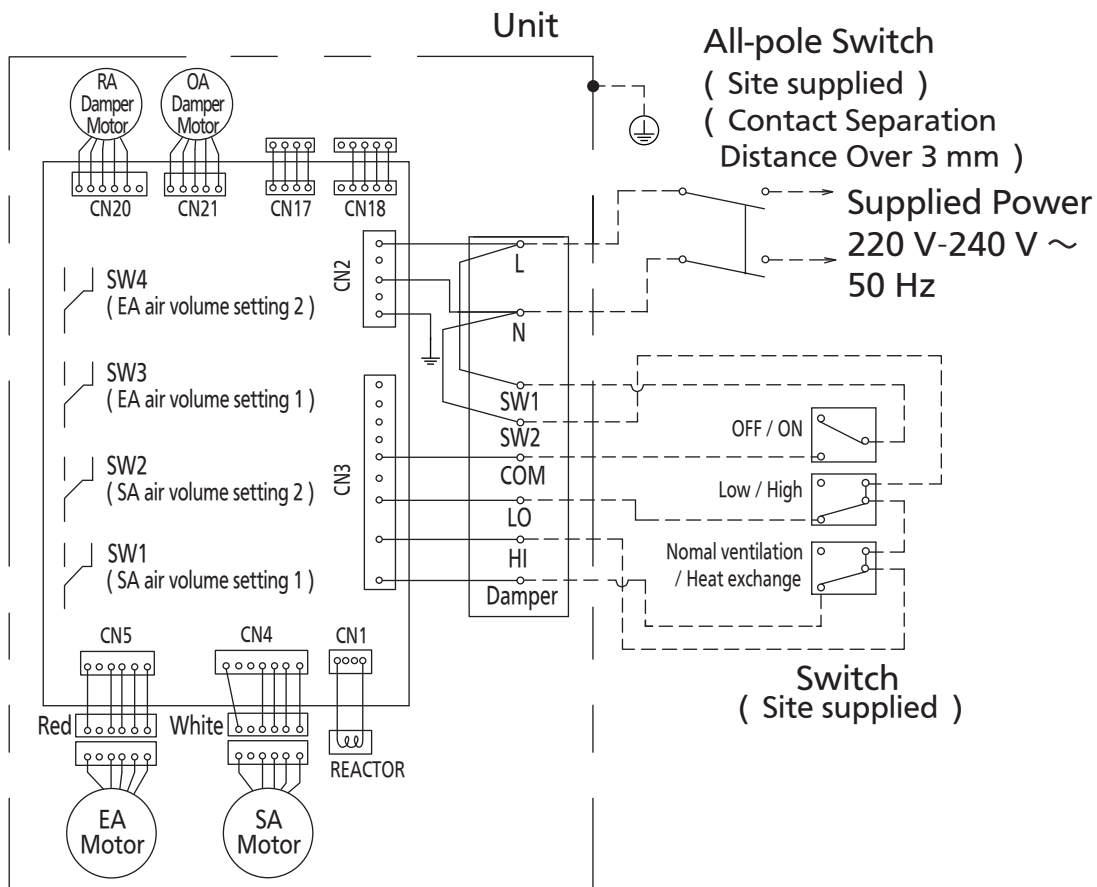

■ FV-1HZY1

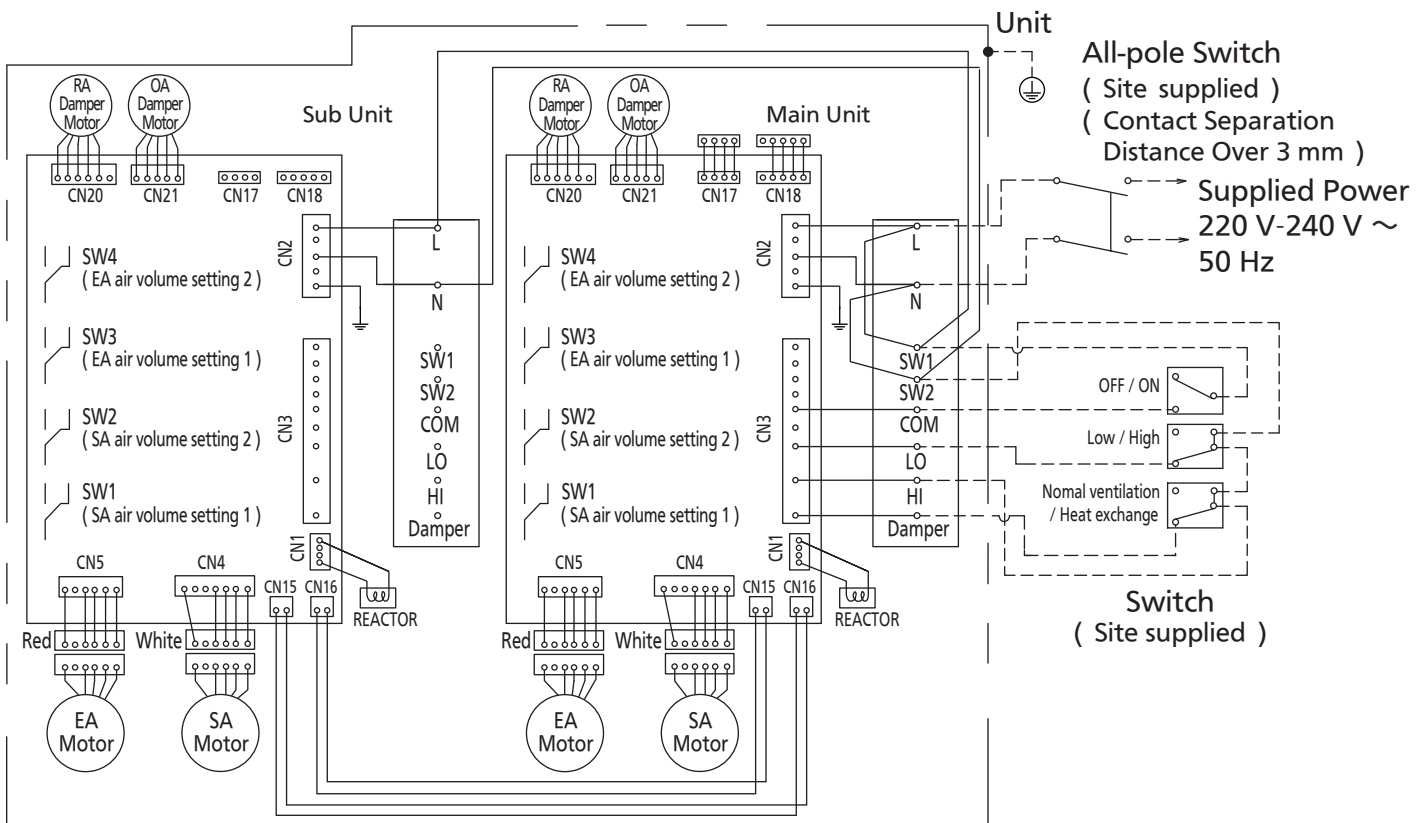

WIRING DIAGRAM

■FV-2KZY1

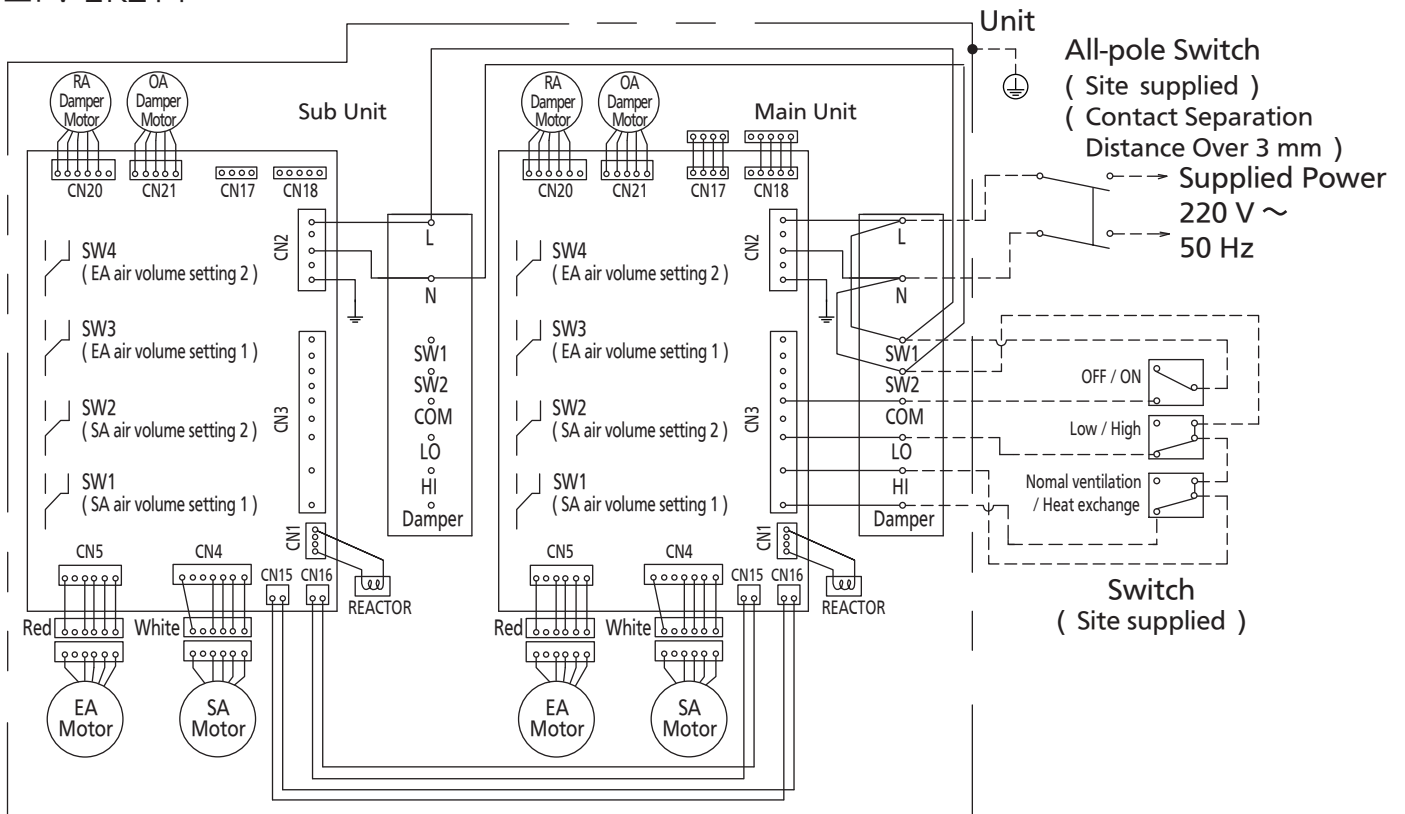

TROUBLESHOOTING

Please check according to the following table. If the abnormality still exists, please power off the product and contact the dealer.

Symptom	Cause	Troubleshooting
<ul style="list-style-type: none"> ● The product does not work when turning on the switch. ● No air blows out. 	<ul style="list-style-type: none"> ● Is the all-pole switch in the mode 「off」 ? 	<ul style="list-style-type: none"> ● Please turn on the all-pole switch.
	<ul style="list-style-type: none"> ● Is there a power failure? 	<ul style="list-style-type: none"> ● After the power supply recovers, press the switch to try running.
<ul style="list-style-type: none"> ● The product stops for a while when the operating mode is selected. 	<ul style="list-style-type: none"> ● Is the filter clogged with dust? 	<ul style="list-style-type: none"> ● Please conduct maintenance according to the maintenance methods. (P.18~20)
	<ul style="list-style-type: none"> ● The product stops to make the damper move smoothly. 	<ul style="list-style-type: none"> ● This is normal and no solution is required.

SPECIFICATIONS

Energy Recovery Mode

FV-80ZY1, FV-1HZY1, FV-1KZY1: 220 V-240 V~ 50 Hz

FV-2KZY1: 220 V~ 50 Hz

Model No.	Notch	Static pressure (Pa)	Air volume (m ³ /h)	Input power (W)	Temperature exchange efficiency (%)		Enthalpy exchange efficiency (%)		Noise (dB(A))	Weight (kg)
					Cooling	Heating	Cooling	Heating		
FV-80ZY1	High	150	800	470~517	63	83	63.5	73	45	60
	Low	54	480	212	73	85	68	75	35	
FV-1KZY1	High	150	1000	550~605	65	82	63	74	46	64
	Low	54	600	235	73	85	69	76	36	
FV-1HZY1	High	130	1500	940~1034	63	83	63.5	73	49	116
	Low	48	900	430	73	85	68	75	41.5	
FV-2KZY1	High	130	2000	1100	65	82	63	74	51	139
	Low	48	1200	490	73	85	69	76	43.5	

- ※ 1. The input power and exchange efficiency are the values measured under the standard air volume.
- 2. The above specifications are the values measured under the factory set.
- 3. The power indicated on the name plate is the maximum value under the static pressure of 0 Pa.
- 4. The noise is measured 1.5 m directly below the center of the energy recovery ventilator.
The noise value of the product is measured in a full anechoic chamber. Under actual conditions, due to the impact of ambient sound, the noise value will be greater than the target value. The noise rises by about 1 dB (A) under reverse installation.
- 5. The air volume in normal ventilation mode is basically the same as the air volume in energy recovery mode.
- 6. The energy recovery efficiency test should be performed according to the method specified in Appendix 4 of JIS B 8628 (2003). The test environmental conditions should be subject to the winter and summer conditions specified in Table 1 and Table 2 of JIS B 8628 (2017). Other test methods should be subject to JIS B 8628 (2003).

OPTIONAL ACCESSORIES

Please contact the dealer to purchase.

■ Filter

Model No.	Outdoor Filter
FV-80ZY1	FV-FP80ZY1
FV-1HZY1 *	
FV-1KZY1	FV-FP1KZY1
FV-2KZY1 *	

* For the FV-1HZY1 or FV-2KZY1 model, two sets are used each time. For other models, one set is used each time.

■ Remote control

Model No.: FV-SWGR1

