

2-WAY GE3 SERIES



Technical focus

- DHW priority setting
- Operating range in heating down to -21°C and up to +24°C for air to water system
- No defrost cycle
- Capacity ratio : 50 ~ 200% (16-25 HP), 50 ~ 170% (30HP)

HP			16HP	20HP	25HP	30HP
Model			U-16GE3E5	U-20GE3E5	U-25GE3E5	U-30GE3E5
Power supply	Voltage	V	220/230/240	220/230/240	220/230/240	220/230/240
	Phase		Single Phase	Single Phase	Single Phase	Single Phase
	Frequency	Hz	50	50	50	50
Cooling capacity		kW	45.00	56.00	71.00	85.00
EER	Cooling	W/W	1.06	1.05	1.02	0.98
Input power cooling		kW	1.17	1.12	1.80	1.80
Hot water in cooling mode (at 65°C outlet)		kW	23.60	29.10	36.40	46.00
Max COP in hot water		W/W	1.55	1.55	1.49	1.47
Gas consumption cooling		kW	41.10	52.10	67.20	84.10
Heating capacity	Standard	kW	50.00	63.00	80.00	95.00
	Low temperature	kW	53.00	67.00	78.00	90.00
COP	Heating	W/W	1.29	1.20	1.15	1.23
Input power heating		kW	0.56	1.05	0.91	1.75
Gas consumption heating	Standard	kW	38.00	51.10	68.60	75.30
	Low temperature	kW	45.40	62.70	60.70	73.90
Starter amperes		A	30	30	30	30
External static pressure		Pa	10	10	10	10
Air volume		m³/min	370	420	460	460
Sound power		dB	80/77	80/77	84/81	84/81
Dimension	HxWxD	mm	2255x1650x1000	2255x1650x1000	2255x2026x1000	2255x2026x1000
Net weight		kg	765	870	880	880
	Liquid pipe	Inch (mm)	1/2 (12.70)	5/8 (15.88)	5/8 (15.88)	3/4 (19.05)
Piping connections	Gas pipe	Inch (mm)	1-1/8 (28.58)	1-1/8 (28.58)	1-1/8 (28.58)	1-1/4 (31.75)
	Balance pipe	Inch (mm)	—	—	—	—
Elevation difference (in/out)			50	50	50	50
Refrigerant (R410A)		kg	11.50	11.50	11.50	11.50
Maximum number of connectable indoor units			26	33	41	50
Operating range	Cool Min - Max	°C (DB)	-10 ~ +43	-10 ~ +43	-10 ~ +43	-10 ~ +43
	Heat Min - Max	°C (WB)	-21 ~ +18	-21 ~ +18	-21 ~ +18	-21 ~ +18

25HP chassis enlarged due to specification improvement. Pre-coat corrosion fin.

16 / 20 HP

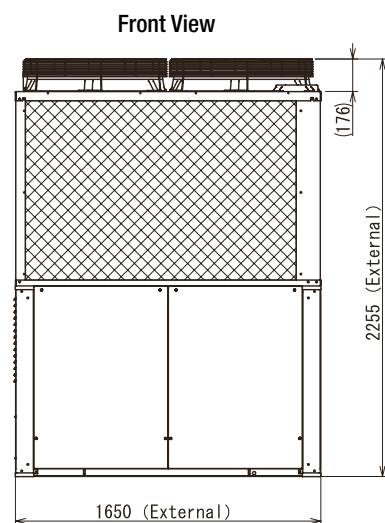
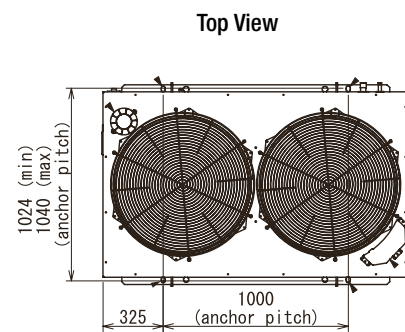

2-WAY GE3 SERIES COMBINATION



Technical focus

- Maximum 60HP combination
- DHW priority setting
- Operating range in heating down to -21°C and up to +24°C for air to water system
- No defrost cycle

- Combination capacity ratio : 50% of smallest outdoor unit capacity ~ 130% of total capacity of outdoor unit combination

HP			32HP	36HP	40HP	45HP	50HP	55HP	60HP
Model			U-16GE3E5 U-16GE3E5	U-16GE3E5 U-20GE3E5	U-20GE3E5 U-20GE3E5	U-20GE3E5 U-25GE3E5	U-25GE3E5 U-25GE3E5	U-25GE3E5 U-30GE3E5	U-30GE3E5 U-30GE3E5
Power supply	Voltage	V	220/230/240	220/230/240	220/230/240	220/230/240	220/230/240	220/230/240	220/230/240
	Phase		Single Phase	Single Phase	Single Phase	Single Phase	Single Phase	Single Phase	Single Phase
	Frequency	Hz	50	50	50	50	50	50	50
Cooling capacity		kW	90.00	101.00	112.00	127.00	142.00	156.00	170.00
Input power cooling		kW	2.34	2.29	2.24	2.92	3.60	3.60	3.60
Hot water in cooling mode (at 65°C outlet)		kW	47.20	52.70	58.20	65.50	72.80	82.40	92.00
Max COP in hot water		W/W	1.55	1.55	1.55	1.52	1.49	1.48	1.47
Gas consumption cooling		kW	82.20	93.20	104.20	119.30	134.40	151.30	168.20
Heating capacity	Standard	kW	100.00	113.00	126.00	143.00	160.00	175.00	190.00
	Low temperature	kW	106.00	120.00	134.00	145.00	156.00	168.00	180.00
Input power heating		kW	1.12	1.61	2.10	1.96	1.82	2.66	3.50
Gas consumption heating	Standard	kW	76.00	89.10	102.20	119.70	137.20	143.90	150.60
	Low temperature	kW	90.80	108.10	125.40	123.40	121.40	134.60	147.80
Starter amperes		A	30	30	30	30	30	30	30
External static pressure		Pa	10	10	10	10	10	10	10
Air volume		m³/min	370/370	370/420	420/420	420/460	460/460	460/460	460/460
Sound power		dB	83/80	83/80	83/80	86/83	87/84	87/84	87/84
	Height	mm	2255	2255	2255	2255	2255	2255	2255
Dimension	Width	mm	1650+100 +1650	1650+100 +1650	1650+100 +1650	1650+100 +2026	2026+100 +2026	2026+100 +2026	2026+100 +2026
	Depth	mm	1000	1000	1000	1000	1000	1000	1000
Net weight		kg	1530(765+765)	1530(765+765)	1530(765+765)	1635(765+870)	1740(870+870)	1750(870+880)	1760(880+880)
	Liquid pipe	Inch (mm)	3/4 (19.05)	3/4 (19.05)	3/4 (19.05)	3/4 (19.05)	3/4 (19.05)	7/8 (22.22)	7/8 (22.22)
Piping connections	Gas pipe	Inch (mm)	1-1/4 (31.75)	1-1/4 (31.75)	1-1/2 (38.10)	1-1/2 (38.10)	1-1/2 (38.10)	1-1/2 (38.10)	1-1/2 (38.10)
	Balance pipe	Inch (mm)	—	—	—	—	—	—	—
Elevation difference (in/out)			50	50	50	50	50	50	
Refrigerant (R410A)		kg	2x11.50	2x11.50	2x11.50	2x11.50	2x11.50	2x11.50	2x11.50
Maximum number of connectable indoor units			52	59	64	64	64	64	64
Operating range	Cool Min - Max	°C	-10 ~ +43	-10 ~ +43	-10 ~ +43	-10 ~ +43	-10 ~ +43	-10 ~ +43	-10 ~ +43
	Heat Min - Max	°C	-21 ~ +18	-21 ~ +18	-21 ~ +18	-21 ~ +18	-21 ~ +18	-21 ~ +18	-21 ~ +18

Data is for reference. 25HP chassis enlarged due to specification improvement. Pre-coat corrosion fin.

25 / 30 HP

