

# Panasonic®

## Operating Instructions

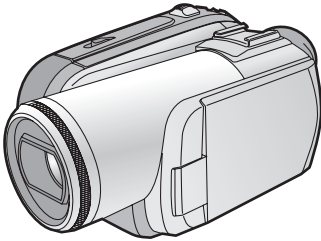

Digital Video Camera

---

Model No. **NV-GS330**



Mini **DV** PAL

Before use, please read these instructions completely.

LEICA  
DICOMAR



## Information for your safety

### WARNING:

- TO REDUCE THE RISK OF FIRE, ELECTRIC SHOCK OR PRODUCT DAMAGE,
- DO NOT EXPOSE THIS APPARATUS TO RAIN, MOISTURE, DRIPPING OR SPLASHING AND THAT NO OBJECTS FILLED WITH LIQUIDS, SUCH AS VASES, SHALL BE PLACED ON THE APPARATUS.
  - USE ONLY THE RECOMMENDED ACCESSORIES.
  - DO NOT REMOVE THE COVER (OR BACK); THERE ARE NO USER SERVICEABLE PARTS INSIDE. REFER SERVICING TO QUALIFIED SERVICE PERSONNEL.

### CAUTION!

- DO NOT INSTALL OR PLACE THIS UNIT IN A BOOKCASE, BUILT-IN CABINET OR IN ANOTHER CONFINED SPACE. ENSURE THE UNIT IS WELL VENTILATED. TO PREVENT RISK OF ELECTRIC SHOCK OR FIRE HAZARD DUE TO OVERHEATING, ENSURE THAT CURTAINS AND ANY OTHER MATERIALS DO NOT OBSTRUCT THE VENTILATION VENTS.
- DO NOT OBSTRUCT THE UNIT'S VENTILATION OPENINGS WITH NEWSPAPERS, TABLECLOTHS, CURTAINS, AND SIMILAR ITEMS.
- DO NOT PLACE SOURCES OF NAKED FLAMES, SUCH AS LIGHTED CANDLES, ON THE UNIT.
- DISPOSE OF BATTERIES IN AN ENVIRONMENTALLY FRIENDLY MANNER.

The socket outlet shall be installed near the equipment and easily accessible. The mains plug of the power supply cord shall remain readily operable. To completely disconnect this apparatus from the AC Mains, disconnect the power supply cord plug from AC receptacle.

Product Identification Marking is located on the bottom of units.

### Warning

Risk of fire, explosion and burns. Do not disassemble.

Do not heat the batteries above the following temperatures or incinerate.

**Button-type battery 60 °C**

**Battery pack 60 °C**

### ■ Carefully read the Operating Instructions and use the Movie Camera correctly.

- Injury or material damage resulting from any kind of use that is not in accordance with the operating procedures explained in these Operating Instructions are the sole responsibility of the user.

### Try out the Movie Camera.

Be sure to try out the Movie Camera before recording your first important event and check that it records properly and functions correctly.

### The manufacturer is not liable for loss of recorded contents.

The manufacturer shall in no event be liable for the loss of recordings due to malfunction or defect of this Movie Camera, its accessories or cassettes.

### Carefully observe copyright laws.

Recording of pre-recorded tapes or discs or other published or broadcast material for purposes other than your own private use may infringe copyright laws. Even for the purpose of private use, recording of certain material may be restricted.

- U.S. Patent Nos. 6,836,549; 6,381,747; 7,050,698; 6,516,132; and 5,583,936.
- This product incorporates copyright protection technology that is protected by U.S. patents and other intellectual property rights. Use of this copyright protection technology must be authorized by Macrovision, and is intended for home and other limited viewing uses only unless otherwise authorized by Macrovision. Reverse engineering or disassembly is prohibited.
- SDHC Logo is a trademark.
- miniSD Logo is a trademark.
- Leica is a registered trademark of Leica Microsystems IR GmbH and Dicomar is a registered trademark of Leica Camera AG.
- All other company and product names in the operating instructions are trademarks or registered trademarks of their respective corporations.

### Files recorded on SD Memory Card

It may not be possible to play back the files on this Movie Camera recorded on and created by other equipment or vice versa. For this reason, check the compatibility of the equipment in advance.

### Pages for reference

Pages for reference are indicated by dashes either side of a number, for example: -00-

The menu operation flow is indicated by >> in the description.

**IF THE POWER CORD OF THIS EQUIPMENT IS DAMAGED, IT MUST BE REPLACED WITH AN ELECTRICALLY APPROVED POWER CORD.**

### Use only the recommended accessories.

- Do not use any other Multi cables and USB cables except the supplied one.
- When you use the cable which are sold separately, please make sure to use the one whose length is less than 3 metres.
- Keep the Memory Card out of reach of children to prevent swallowing.

### -If you see this symbol-

#### Information on Disposal in other Countries outside the European Union



This symbol is only valid in the European Union. If you wish to discard this product, please contact your local authorities or dealer and ask for the correct method of disposal.

---

Before opening the CD-ROM package, please read the following.

## ***End User License Agreement (for USB Driver, SweetMovieLife and MotionDV STUDIO)***

You ("Licensee") are granted a license for the Software defined in this End User Soft Agreement ("Agreement") on condition that you agree to the terms and conditions of this Agreement. If Licensee does not agree to the terms and conditions of this Agreement, promptly return the Software to Matsushita Electric Industrial Co., Ltd. ("Matsushita"), its distributors or dealers from which you made the purchase.

### **Article 1 License**

Licensee is granted the right to use the software, including the information recorded or described on the CD-ROM, instruction manuals, and any other media provided to Licensee (collectively "Software"), but all applicable rights to patents, copyrights, trademarks and trade secrets in the Software are not transferred to Licensee.

### **Article 2 Use by a Third Party**

Licensee may not use, copy, modify, transfer or allow any third party, whether free of charge or not, to use, copy or modify the Software, except as expressly provided for in this Agreement.

### **Article 3 Restrictions on Copying the Software**

Licensee may make a single copy of the Software in whole or a part solely for back-up purpose.

### **Article 4 Computer**

Licensee may use the Software only on one computer, and may not use it on more than one computer.

### **Article 5 Reverse Engineering, Decompiling or Disassembly**

Licensee may not reverse engineer, decompile, or disassemble the Software, except to the extent either of them is permitted under law or regulation of the country where Licensee resides. Matsushita, or its distributors will not be responsible for any defects in the Software or damage to Licensee caused by Licensee's reverse engineering, decompiling, or disassembly of the Software.

### **Article 6 Indemnification**

The Software is provided "AS-IS" without warranty of any kind, either expressed or implied, including, but not limited to, warranties of non-infringement, merchantability and/or fitness for a particular purpose. Further, Matsushita does not warrant that the operation of the Software will be uninterrupted or error free. Matsushita or any of its distributors will not be liable for any damage suffered by Licensee arising from or in connection with Licensee's use of the Software.

### **Article 7 Export Control**

Licensee agrees not to export or re-export to any country the Software in any form without the appropriate export licenses under regulations of the country where Licensee resides, if necessary.

### **Article 8 Termination of License**

The right granted to Licensee hereunder will be automatically terminated if Licensee contravenes of any of the terms and conditions of this Agreement. In the event, Licensee must destroy the Software and related documentation together with all the copies thereof at Licensee's own expense.

## Contents

Information for your safety .....	2
-----------------------------------	---

### Before using

Accessories.....	6
Optional.....	6
Parts identification and handling.....	6
Fitting the lens cap.....	8
The grip belt.....	9
Power supply.....	9
Charging time and recordable time.....	11
Turning the camera on.....	11
Setting date and time.....	12
Using the LCD monitor.....	13
Using the viewfinder.....	13
Quick Start.....	14
Inserting/removing a cassette.....	15
Inserting/removing a card.....	16
Selecting a mode.....	17
How to use the joystick.....	17
Help mode.....	19
Switching the language.....	19
Using the menu screen.....	19
Adjusting LCD monitor/viewfinder.....	21
Using the remote control.....	22

### Record mode

Check before recording.....	24
Recording on a tape.....	25
Recording check.....	26
Blank search function.....	26
Recording still pictures on a card while recording image onto a tape.....	27
Recording still pictures onto a card (Photoshot).....	27
Zoom in/out function.....	29
Recording yourself.....	30
Backlight compensation function.....	30
Colour night view function.....	31
Soft skin mode.....	31
Tele macro function.....	32
Fade in/fade out function.....	32
Wind noise reduction function.....	33
Anti-Ground-Shooting (AGS).....	33
Self-timer recording.....	34
Wide/4:3 Function.....	34
Image stabilizer function.....	35
Guideline function.....	35
Recording in various situations (Scene mode).....	35
Recording in natural colours (White balance).....	36
Manual focus adjustment.....	37
Manual shutter speed/aperture adjustment.....	38

### Playback mode

Playing back tape.....	39
Slow-motion playback/ frame-by-frame playback.....	40
Variable-speed search function.....	40
Playback on TV.....	41
Playing back card.....	42
Deleting files recorded on a card.....	43
Formatting a card.....	43
Protecting files on a card.....	44
Writing the printing data on a card (DPOF setting).....	44

### Edit mode

Recording from a tape onto a card.....	45
Copying onto a DVD recorder or a VCR (Dubbing).....	45
Using the DV Cable for Recording (Digital Dubbing).....	46
Audio dubbing.....	47
Printing pictures by directly connecting to the printer (PictBridge).....	48

### With a PC

Before Use.....	50
Install/Connection.....	53
Software.....	57
Others.....	59

### Menu

Menu list.....	63
Menus related to taking pictures.....	65
Menus related to playback.....	65
Other menus.....	65

### Others

Indications.....	66
Warning/alarm indications.....	67
Functions cannot be used simultaneously.....	68
Before requesting repair (Problems and solutions).....	69
Cautions for Use.....	72
Explanation of terms.....	76

### Specifications

Specifications.....	78
---------------------	----

## Before using

### Accessories

The followings are the accessories supplied with this product.

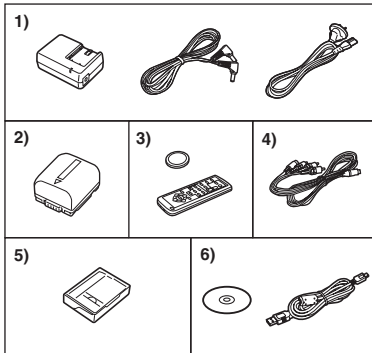

- 1) AC adaptor, DC input lead, AC mains lead -10-
- 2) Battery pack -9-
- 3) Remote control, button-type battery -22-
- 4) Multi cable -45-
- 5) Digital video head cleaner -73-
- 6) USB cable and CD-ROM -48-, -50-

### Optional

- 1) AC adaptor (VW-AD11GN)
  - 2) Battery pack (lithium/VW-VBG130/1320 mAh)
  - 3) Battery pack (lithium/VW-VBG260/2640 mAh)
  - 4) Battery pack (lithium/VW-VBG6\*/5800 mAh)
  - 5) Battery pack holder kit (VW-VH04)
  - 6) Wide conversion lens (VW-LW3707M3E)
  - 7) Tele conversion lens (VW-LT3714ME)
  - 8) Filter kit (VW-LF37WE)
  - 9) Video DC light (VW-LDC102E)
  - 10) Light bulb for video DC light (VZ-LL10E)
  - 11) Tripod (VW-CT45E)
  - 12) DV cable (VW-CD1E)
- Some optional accessories may not be available in some countries.
  - \* The battery pack holder kit VW-VH04 (optional) is necessary.

## Parts identification and handling

### ■ Camera

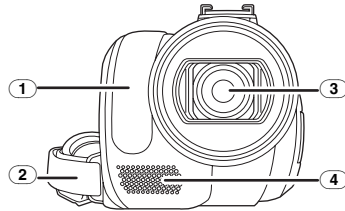

- ① White balance sensor -37-
- Remote control sensor -23-
- ② Grip belt -9-
- ③ Lens (LEICA DICOMAR)
- ④ Microphone (built-in, stereo) -29-, -33-

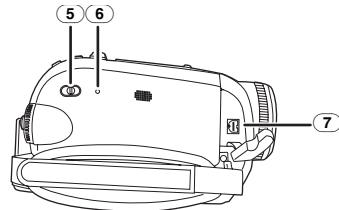

- ⑤ Mode select switch [AUTO/MANUAL/ FOCUS] -24-, -35-, -36-, -38-
- ⑥ Reset button [RESET] -71-
- ⑦ Audio-video/S-Video output terminal [A/V] -45-

- Use the supplied Multi cable only, otherwise audio may not be played back normally.

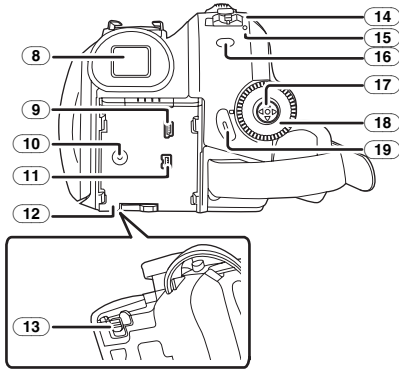

8 Viewfinder -13-, -76-

Due to limitations in LCD production technology, there may be some tiny bright or dark spots on the Viewfinder screen. However, this is not a malfunction and does not affect the recorded picture.

- 9 USB terminal [↓] -48-, -57-
- 10 DC input terminal [DC/C.C.IN] -10-
- 11 DV input/output terminal [DV] -46-
- 12 Battery holder -10-
- 13 Battery release lever [BATTERY] -10-
- 14 Power switch [OFF/ON] -11-
- 15 Status indicator -11-
- 16 Menu button [MENU] -19-
- 17 Joystick -17-
- 18 Mode dial -17-
- 19 Recording start/stop button -25-

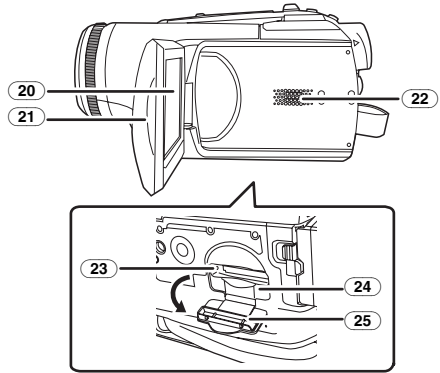

20 LCD monitor -13-, -76-

Due to limitations in LCD production technology, there may be some tiny bright or dark spots on the LCD monitor screen. However, this is not a malfunction and does not affect the recorded picture.

- 21 LCD monitor open part -13-
- 22 Speaker -39-
- 23 Card access lamp -16-
- 24 Card slot -16-
- 25 Card slot cover -16-

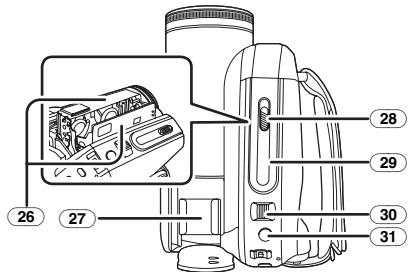

- 26 Cassette holder -15-
- 27 Accessory shoe
- Accessories, such as a video DC light (VW-LDC102E; optional), are attached here.
- 28 Cassette eject lever [OPEN/EJECT] -15-
- 29 Cassette cover -15-
- 30 Zoom lever [W/T] -29-
- Volume lever [- □ /VOL+] -39-
- 31 Photoshot button [ ] -27-

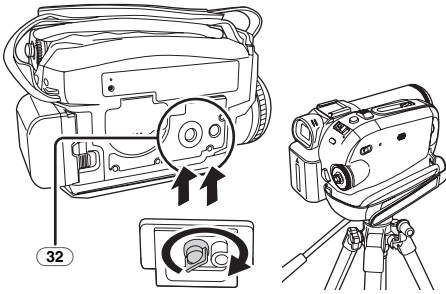

**32 Tripod receptacle**

This is a hole for attaching the camera to optional tripod/VW-CT45E. (Please carefully read the operating instructions for how to attach the tripod to the camera.)

- You cannot open the card slot cover when the tripod is used. Insert the card first and then attach the tripod.

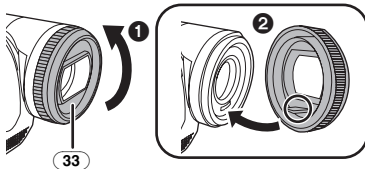

**33 Lens hood**

In order to remove the lens hood, rotate it counterclockwise ①. In order to fit it, put into slot ②, and then rotate it clockwise.

- Fit the MC protector or the ND filter of the Filter Kit (VW-LF37WE; optional) in front of the lens hood. Do not fit the other accessories on the hood. (Except for the lens cap)  
(Refer to the operating instructions for the Filter Kit.)
- When fitting the tele conversion lens (VW-LT3714ME; optional) or the wide conversion lens (VW-LW3707M3E; optional), first remove the lens hood.  
(Refer to the operating instructions for the tele conversion lens or the wide conversion lens.)
- When 2 lens accessories, such as the ND filter and tele conversion lens, are fitted and the [W/T] lever is pressed toward the [W] side, the 4 corners of an image will be darkened. (Vignetting) (When fitting 2 lens accessories, first remove the lens hood and then fit them.)

**Fitting the lens cap**

Fit the lens cap to protect the surface of the lens.

- The lens cap and the lens cap cord come pre-attached to the grip belt.
- When not using the lens cap, pull the lens cap cord in the direction of the arrow. ①
- When you are not recording, be sure to cover the lens with the lens cap for protection. ②

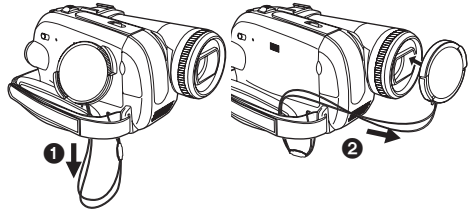

- When you remove the lens cap, press the knobs firmly.

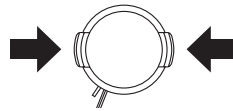



## The grip belt

Adjust the belt length so it fits your hand.

### 1 Adjust the belt length and the pad position.

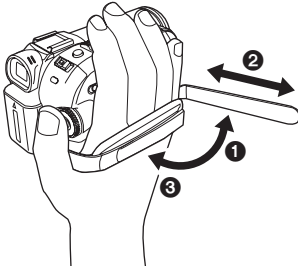

- ❶ Flip the belt.
- ❷ Adjust the length.
- ❸ Fix the belt.

## Power supply

### ■ Charging the battery

When this product is purchased, the battery is not charged. Charge the battery before using this product.

- Battery charging time (-11-)
- We recommend using Panasonic batteries. (-6-)
- If you use other batteries, we cannot guarantee the quality of this product.
- If the DC input lead is connected to the AC adaptor, then the battery will not get charged. Remove the DC input lead from the AC adaptor.

#### 1 Connect the AC mains lead to the AC adaptor and the AC mains socket.

#### 2 Put the battery on the battery mount by aligning the mark, and then securely plug it in.

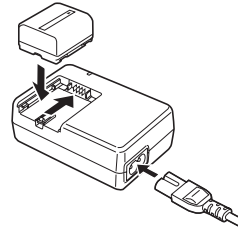

### ■ Charging lamp

Lights up: Charging

Goes off: Charging completed

Flashing: The battery is over discharged (discharged excessively). In a while, the lamp will light up and normal charging will start.

When the battery temperature is excessively high or low, the [CHARGE] lamp flashes and the charging time will be longer than normal.

### ■ Connecting to the AC outlet

The unit is in the standby condition when the AC adaptor is connected. The primary circuit is always "live" as long as the AC adaptor is connected to an electrical outlet.

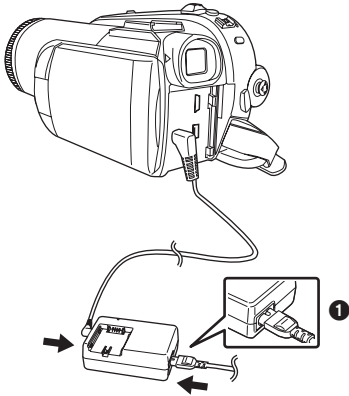

- 1 Connect the AC mains lead to the AC adaptor and the AC mains socket.
- 2 Connect the DC input lead to the AC adaptor.
- 3 Connect the DC input lead to this product.

- The output plug of the AC mains lead is not completely connected to the AC adaptor socket. As shown in ①, there is a gap.
- Do not use the power cord for other equipment since the power cord is exclusively designed for the movie camera. Or do not use the power cord of other equipment for the movie camera.

### ■ Fitting the battery

Push the battery against the battery holder and slide it until it clicks.

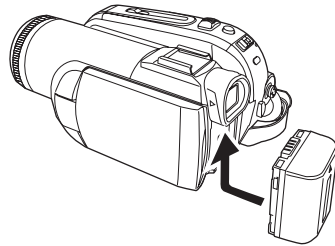

### ■ Removing the battery

While sliding the [BATTERY] lever, slide the battery to remove it.

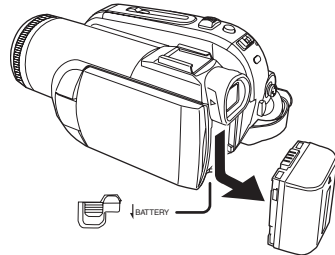

- Hold the battery with your hand so it does not fall.
- Before removing the battery, be sure to set the [OFF/ON] switch to [OFF].
- Do not heat or expose to flame.
- Do not leave the battery(ies) in an automobile exposed to direct sunlight for a long period of time with doors and windows closed.

### CAUTION

Danger of explosion if battery is incorrectly replaced. Replace only with the same or equivalent type recommended by the manufacturer. Dispose of used batteries according to the manufacturer's instructions.

## Charging time and recordable time

The times shown in the tables below are for when the temperature is 25 °C and the humidity is 60%. If the temperature is higher or lower than 25 °C, the charging time will become longer.







Supplied battery/ (7.2 V/ 640 mAh)	(A)	1 h 40 min
	(B)	1 h 15 min (1 h 10 min)
	(C)	30 min (30 min)
VW-VBG130 (7.2 V/ 1320 mAh)	(A)	2 h 40 min
	(B)	2 h 10 min (2 h)
	(C)	55 min (55 min)
VW-VBG260 (7.2 V/ 2640 mAh)	(A)	4 h 55 min
	(B)	4 h 25 min (4 h 5 min)
	(C)	1 h 55 min (1 h 50 min)
VW-VBG6 (7.2 V/ 5800 mAh)	(A)	10 h 30 min
	(B)	10 h 10 min (9 h 25 min)
	(C)	4 h 30 min (4 h 10 min)

- (A) Charging time
- (B) Maximum continuously recordable time
- (C) Actual recordable time

(The actual recordable time refers to the recordable time on a tape when repeatedly starting/stopping recording, turning the unit on/off, moving the zoom lever, etc.)

“1 h 10 min” indicates 1 hour 10 minutes.

- The charging time and recordable time shown in the table are approximations. The times indicate the recordable times when the viewfinder is used. The times in parentheses indicate the recordable times when the LCD monitor is used.
- We recommend the Battery Pack VW-VBG130, VW-VBG260 and VW-VBG6 for long time recording (2 hours or more for continuous recording, 1 hour or more for actual recording).

- The actual time may become shorter than this. The recordable time shown in the table are approximations. The recordable time will become shorter in the following cases:
  - When you use both the viewfinder and the LCD monitor simultaneously while rotating the LCD monitor frontward to record yourself, etc.
  - When you use this camera with the LCD monitor lit up with the [POWER LCD] setting.
- The batteries heat up after use or charging. The main unit of the movie camera being used will also heat up. This is normal.
- Along with the reduction of the battery capacity, the display will change:  →  →  → . If the battery discharges, then  (  ) will flash.

## Turning the camera on

When the camera is turned on with the lens cap fitted, the automatic white balance adjustment (-76-) may not function properly. Please turn the camera on after removing the lens cap.

### How to turn on the power

- 1 While pressing the button , set the [OFF/ON] switch to [ON].

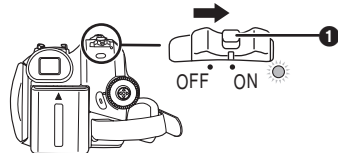

- The Status indicator lights red and the power turns on.
- In Tape Recording Mode or Card Recording Mode, if the [OFF/ON] switch is set to [ON] while the LCD monitor is closed and the viewfinder is retracted, the power turns off.

### How to turn off the power

- 1 While pressing the button , set the [OFF/ON] switch to [OFF].

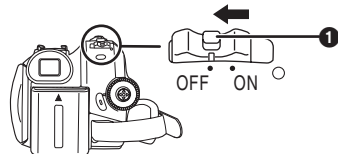

- Set the [OFF/ON] switch to [OFF] when not using the camera.
- The status indicator goes off when the power turns off.

## How to turn the power on and off with the LCD monitor/viewfinder

When the power switch is set to [ON], the power can be turned on and off with the LCD monitor and the viewfinder when the unit is in Tape Recording Mode or Card Recording Mode.



### 1 Open the LCD monitor out or extend the viewfinder to use. (-13-)

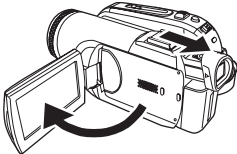

- The LCD monitor or viewfinder will be activated.

### 2 Close the LCD monitor and retract the viewfinder.

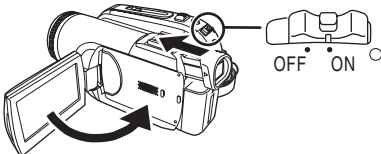

- The power will not turn off unless the LCD monitor is closed and the viewfinder is retracted.
- The Status indicator automatically goes off and the power turns off. (If quick start is set to [ON] (-14-), the unit goes into quick start standby mode and the Status indicator lights green.)
- **The power does not turn off even if the LCD monitor is closed and the viewfinder is retracted while recording on a tape.**

### 3 Open the LCD monitor or extend the viewfinder to turn the power on and use the movie camera again.

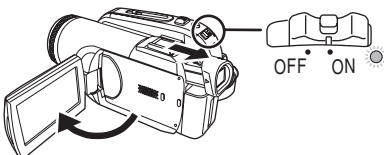

- The status indicator lights red and the power turns on.

## Setting date and time

When the movie camera is turned on for the first time, [SET DATE AND TIME] will appear.

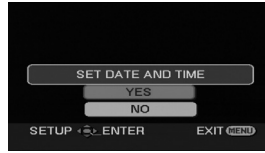

- Select [YES] and press the centre of the joystick. Do steps 2 and 3 below to set the date/time.

If the screen shows the incorrect date/time, then adjust it.

### Set to Tape Recording Mode or Card Recording Mode.

#### 1 Set [BASIC] >> [CLOCK SET] >> [YES]. (-19-)



#### 2 Move the joystick left or right in order to select the item to be set. Then move the joystick up or down to set the desired value.

- The year will change as follows:  
2000, 2001, ..., 2089, 2000, ...
- The 24-hour clock is used.

#### 3 Press the joystick to determine the setting.

- The clock function starts at [00] seconds.

### About date/time

- The date and time function are driven by a built-in lithium battery.
- Make sure to check the time before recording because the built-in clock is not very accurate.

## ■ Recharging the built-in lithium battery

- If [⊕] or [-] is appears when the camera is turned on, then the built-in lithium battery has run down. Use the steps below to charge the battery. When turn on the power for the first time after charging, [SET DATE AND TIME] will appear. Select [YES] and set the date and time. Connect the AC adaptor to the camera or attach the battery to the camera, and the built-in lithium battery will be recharged. Leave the camera as is for approx. 24 hours, and the battery will drive the date and time for approx. 6 months. (Even if the [OFF/ON] switch is set to [OFF], the battery is still being recharged.)

### WARNING

THE LITHIUM BATTERY IN THIS UNIT MUST ONLY BE REPLACED BY QUALIFIED PERSONNEL. IF THIS IS NECESSARY, CONTACT THE PANASONIC CUSTOMER CARE CENTRE ON 132600 FOR YOUR NEAREST AUTHORIZED SERVICE CENTRE.

## Using the LCD monitor

You can record the image while viewing it on the opened LCD monitor.

- 1 Put a finger on the LCD monitor open part and pull the LCD monitor out in the direction of the arrow.

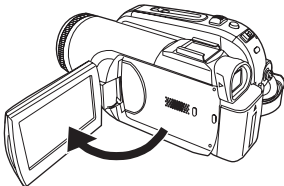

- It can open up to 90°.

- 2 Adjust the angle of the LCD monitor according to your preference.

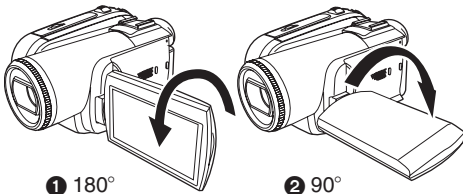

- It can rotate up to 180° ① towards the lens or 90° ② towards the viewfinder.

- The brightness and colour level of the LCD monitor can be adjusted from the menu.
- If it is forcibly opened or rotated, the camera may be damaged or fail.
- If the LCD monitor is rotated by 180° towards the lens and the viewfinder is extended (when recording yourself), the LCD monitor and the viewfinder simultaneously light.

## Using the viewfinder

### ■ Extending the viewfinder

- 1 Pull out the viewfinder and extend it by pinching the extension knob.

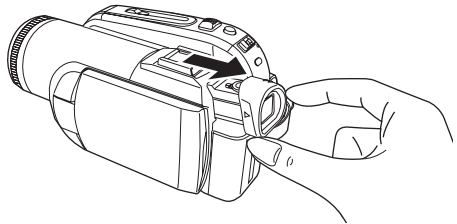

- The viewfinder will be activated. (If the LCD monitor is opened, the viewfinder will be deactivated.)

### ■ Adjusting the field of view

- 1 Adjust the focus by sliding the eyepiece corrector knob.

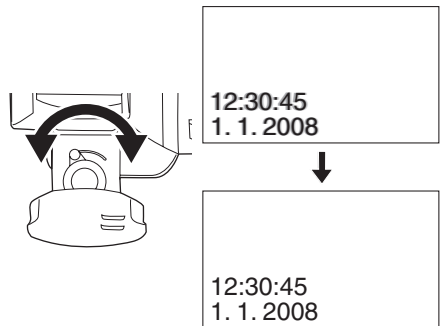

- You can adjust the brightness of the viewfinder from the menu.

## Quick Start

When quick start is ON the battery power is still being consumed, even when the LCD monitor and the viewfinder are closed.

The movie camera will resume recording/pause mode about 1.7 seconds after the LCD monitor or the viewfinder is reopened.

- Please note in quick start mode approximately half the pause recording power is being consumed. Using quick start mode will reduce the battery recording/playback time.
- This is only activated in the following cases.
  - While using the battery
    - A tape or a card is inserted, while the Tape Recording Mode is set.
    - A card is inserted, while the Card Recording Mode is set.
  - While using the AC adaptor
    - quick start can be used even if a tape/card is not inserted.

### ● Set to Tape/Card Recording Mode.

#### 1 Set [SETUP] >> [QUICK START] >> [ON].

(-19-)

#### 2 While the [OFF/ON] switch is still set to [ON], close the LCD monitor and retract the viewfinder.

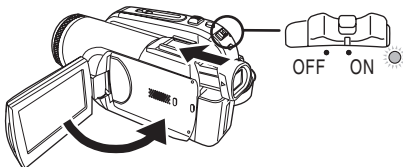

- The Status indicator lights green and the unit goes into quick start standby mode.
- The movie camera will not go into quick start standby unless the LCD monitor is closed and the viewfinder is retracted.

#### 3 Open the LCD monitor or extend the Viewfinder.

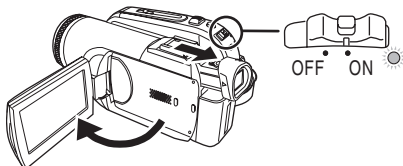

- The Status indicator lights red and the camera is put into recording pause approx. 1.7 seconds after it is turned on.

## ■ To cancel Quick Start

### 1 Set [SETUP] >> [QUICK START] >> [OFF].

(-19-)

- If the [OFF/ON] switch is set to [OFF] while the unit is in quick start standby, the power turns off.
  - If the standby continues for approx. 30 minutes, then the status indicator will go off and the camera will be completely turned off.
- 
- In the following cases, quick start is cancelled and the power turns off.
    - When the Mode dial is moved.
    - When the battery or AC adaptor is removed.
    - When both the tape and card are removed while using the battery in Tape Recording Mode.
    - When the card is removed while using the battery in Card Recording Mode.
  - When the camera is quick-started with the white balance on automatic, it may take some time until the white balance is adjusted if the scene being recorded has a light source different from the scene last recorded. (When the colour night view function is used, however, the white balance of the scene last recorded is retained.)
  - If the power is turned on in quick start standby, the zoom magnification becomes 1× and the picture size may differ from what it was before quick start standby.
  - If [POWER SAVE] (-65-) is set to [5 MINUTES] and the unit automatically goes into quick start standby mode, set the [OFF/ON] switch to [OFF], then to [ON] again. Also, close the LCD monitor and retract the viewfinder and then open the LCD monitor or extend the viewfinder again.

## Inserting/removing a cassette

- 1 Fit the AC adaptor or the battery and turn on the power.
- 2 Slide the [OPEN/EJECT] lever and open the cassette cover.

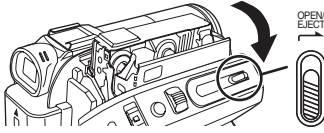

- When the cover is fully opened, the cassette holder will come out.

- 3 After the cassette holder is opened, insert/remove the cassette.

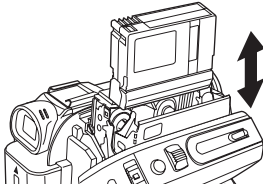

- When inserting a cassette, orient it as shown in the figure, and then securely insert it as far as it goes.
- When removing, pull it straight out.

- 4 Push the [PUSH] mark ① in order to close the cassette holder.

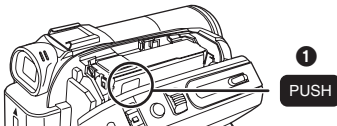

- The cassette holder is housed.

- 5 Only after the cassette holder is completely housed, close the cassette cover tightly.

- When inserting a previously recorded cassette, use the blank search function to find the position where you want to continue recording. If you are overwriting a previously recorded cassette, be sure to find the position where you want to continue recording.
- When closing the cassette cover, do not get anything, such as a cable, caught in the cover.
- After use, be sure to rewind the cassette completely, remove it and put it in a case. Store the case in an upright position. (-75-)
- If the indicator of the condensation does not display on the LCD monitor and/or viewfinder and you notice condensation on the lens or the main unit, do not open the cassette cover otherwise condensation may be formed on the heads or the cassette tape. (-72-)

### ■ When the cassette holder does not come out

- Close the cassette cover completely, and then open it again completely.
- Check if the battery has run down.

### ■ When the cassette holder cannot be housed

- Set the [OFF/ON] switch to [OFF], then to [ON] again.
- Check if the battery has run down.

### ■ Accidental erasure prevention

If the accidental erasure prevention slider ① of a cassette is opened (slide in the direction of the [SAVE] arrow), the cassette cannot be recorded. When recording, close the accidental erasure prevention slider of the cassette (slide in the direction of the [REC] arrow).

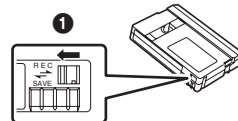

## Inserting/removing a card

Before inserting/removing a card, set the [OFF/ON] switch to [OFF].

- If the card is inserted or removed with the power turned on, this camera may malfunction or the data recorded on the card may be lost.

### 1 Turn off the power ❶.

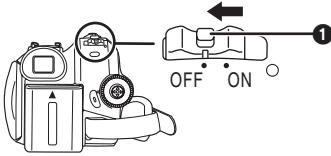

- Check that the Status indicator has gone off.

### 2 Open the card slot cover.

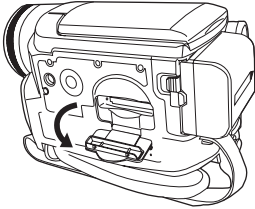

### 3 Insert/remove the card into/from the card slot.

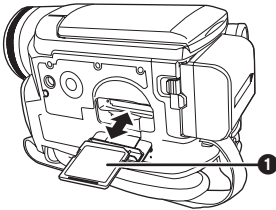

- When inserting a card, face the label side ❶ towards you and push it straight in with one stroke as far as it goes.
- When removing the card, press the centre of the card and then pull it straight out.

### 4 Securely close the card slot cover.

#### Concerning the card

- Do not format the card with another movie camera or any personal computer. This operation may make the card unusable.
- If you wish to use Memory Cards that are 4 GB, SDHC Memory Cards only can be used.
- Memory Cards greater than 4 GB without the SDHC Logo are not compliant with the SD specifications.

#### Card access lamp

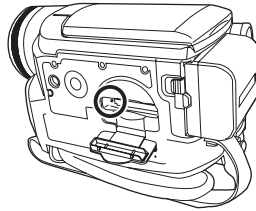

- When the camera accesses the card (reading, recording, playback, erasing, etc.), the access lamp lights up.
- If the following operations are performed when the access lamp is lit, then the card or the recorded data may be damaged or the camera may malfunction.
  - Inserting or removing the card.
  - Operating the [OFF/ON] switch or the mode dial.
  - Removing the battery or AC adaptor.

#### SD Card

- The memory capacity indicated on the SD Card label corresponds to the total amount of capacity to protect and manage the copyright and the capacity available as conventional memory for a movie camera, personal computer or other equipment.

This unit is compatible with both SD Memory cards and SDHC Memory cards. You can only use SDHC Memory cards on devices that are compatible with them. You cannot use SDHC Memory cards on devices that are only compatible with SD Memory cards. (When using a SDHC Memory card on another device, be sure to read the operating instructions for that device.)

#### Concerning the write protection switch on the SD Card

- The SD Card has a write protection switch on it. If the switch is moved to [LOCK], you cannot write to the card, erase the data on it, or format it. If it is moved back, you can.



## Selecting a mode

Rotate the mode dial to select the desired mode.

### 1 Rotate the mode dial.

- Set your desired mode to ①.

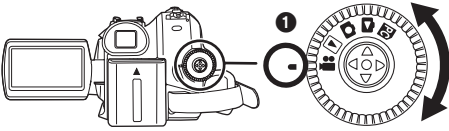

#### TAPE RECORDING MODE

Use this when you record the image on a tape.  
(Also, you can simultaneously record still pictures on a card while recording images on a tape.)

#### TAPE PLAYBACK MODE

Use this to play back a tape.

#### CARD RECORDING MODE

Use this to record still pictures on a card.

#### CARD PLAYBACK MODE

Use this to play back the still pictures recorded on a card.

#### PC CONNECTION MODE

You can view or edit the images recorded on a card on your personal computer. -50-

## How to use the joystick

### Basic joystick operations

Operations on the menu screen and selection of files to be played back on the multi-image display

Move the joystick up, down, left, or right to select an item or file, and then push in the centre to set it.

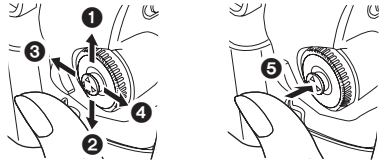

①	Select by moving up.
②	Select by moving down.
③	Select by moving left.
④	Select by moving right.
⑤	Determine by pushing the centre.

### Joystick and screen display

Push the centre of the joystick, and icons will be displayed on the screen. Each time the joystick is moved down, the indication changes.

(In the Tape playback mode or the Card Playback Mode, the icons will be automatically displayed on the screen.)

#### 1) Tape recording mode

([AUTO/MANUAL/FOCUS] switch is set to [AUTO])

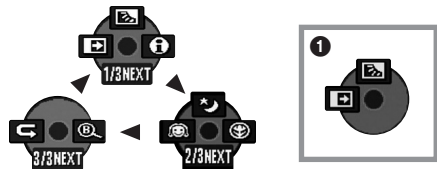

1/3	◀	Fade	-32-
	▲	Backlight compensation	-30-
	▶	Help mode	-19-
2/3	◀	Soft skin mode	-31-
	▶	Tele macro	-32-
	▲	Colour night view	-31-
3/3	◀	Recording check	-26-
	▶	Blank search	-26-

- ① is displayed while recording on a tape.

2) Tape recording mode  
 ([AUTO/MANUAL/FOCUS] switch is set to [MANUAL])

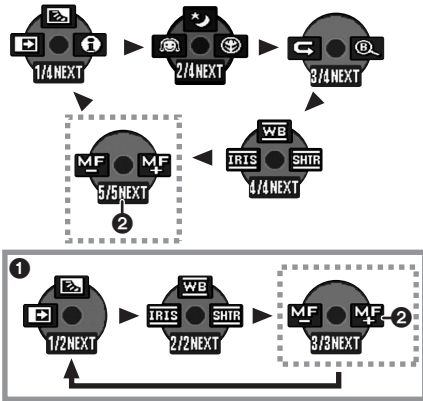

4/4	◀	IRIS	Iris or gain value	-38-
	▲	WB	White balance	-36-
	▶	SHTR	Shutter speed	-38-
5/5	◀	MF-	Manual focus adjustment	-37-
	▶	MF+		

- ❶ is displayed while recording on a tape.
- ❷ is displayed only when the [AUTO/MANUAL/FOCUS] switch is set to [FOCUS].

3) Tape playback mode



	▲	▶/⏸	Playback/pause	-39-
	▼	■	Stop	-39-
	◀	◀◀	Rewind (review playback)	-39-
	▶	▶▶	Fast forward (cue playback)	-39-

4) Card recording mode  
 ([AUTO/MANUAL/FOCUS] switch is set to [AUTO])

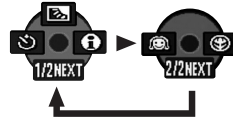

1/2	◀	⌚	Self-timer recording	-34-
	▲	☀	Backlight compensation	-30-
2/2	▶	ℹ	Help mode	-19-
	▶	😊	Soft skin mode	-31-
	▶	🔍	Tele macro	-32-

5) Card recording mode  
 ([AUTO/MANUAL/FOCUS] switch is set to [MANUAL])

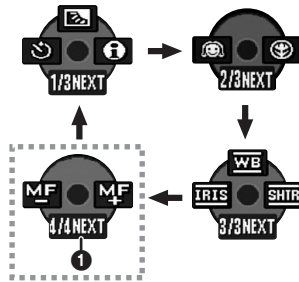

3/3	◀	IRIS	Iris or gain value	-38-
	▲	WB	White balance	-36-
	▶	SHTR	Shutter speed	-38-
4/4	◀	MF-	Manual focus adjustment	-37-
	▶	MF+		

- ❶ is displayed only when the [AUTO/MANUAL/FOCUS] switch is set to [FOCUS].

6) Card Playback Mode



	▲	▶/⏸	Slide show start/pause	-42-
	▼	🗑	Delete	-43-
	◀	◀	Playback the previous picture	-42-
	▶	▶	Playback the next picture	-42-

## Help mode

Select an icon for an explanation of the function.

### ● Set to Tape/Card Recording Mode.

1 Press the joystick to display the icon during the recording pause. Move the joystick down until icon ① appears.



2 Move the joystick right to select the Help mode icon (①).

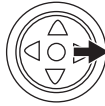

3 Move the joystick up, left, or right to select the desired icon.

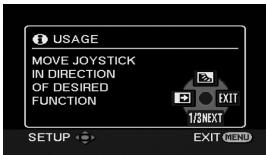

- An explanation of the selected icon is displayed on the screen.
- Each time the joystick is moved down, the indication changes.

### ■ To exit the Help mode

Select [EXIT] icon or press the [MENU] button.

- When the Help mode is used, it is not possible to record or set the functions.

## Switching the language

You can switch the language on the screen display or the menu screen.

1 Set [LANGUAGE] >> select the desired language.



## Using the menu screen

For each individual menu, please refer to -63-.

1 Press the [MENU] button.

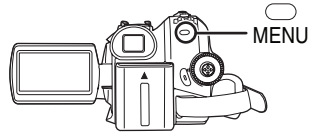

- The menu corresponding to the mode selected by the mode dial is displayed.
- Do not switch the mode dial when the menu is displayed.

2 Move the joystick up or down in order to select the top menu.

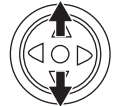

3 Move the joystick right or press it to set the selection.



4 Move the joystick up or down in order to select the sub-menu.

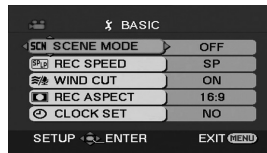

**5 Move the joystick right or press it to set the selection.**



**6 Move the joystick up or down in order to select the item to be set.**

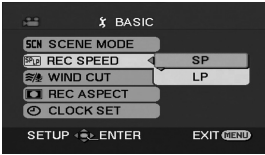

**7 Press the joystick to determine the setting.**



**■ To exit the menu screen**

Press the [MENU] button.

**■ To get back to the previous screen**

Move the joystick left.



**■ About the menu setting**

- The menu is not displayed while recording on a tape or a card. Also, you cannot record on a tape or a card while the menu is displayed.

**■ Operating with remote control**

The menu screen transition is the same as when the buttons on the main unit are used.

**1 Press the [MENU] button.**

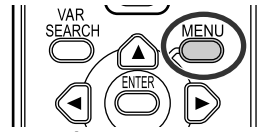

**2 Select a menu item.**

- Use the direction buttons (▲, ◀, ▶, ▼) and [ENTER] button in place of the joystick on the main unit.

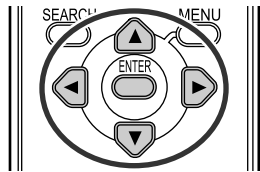

**3 Press the [MENU] button to exit the menu screen.**

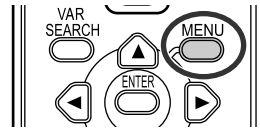

## Adjusting LCD monitor/viewfinder

### ■ Adjusting the brightness and colour level

1 Set [SETUP] >> [LCD SET] or [EVF SET] >> [YES].

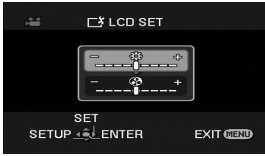

2 Move the joystick up or down in order to select the item to be adjusted.

[LCD SET]

☼ :Brightness of the LCD monitor

⊗ :Colour level of the LCD monitor

[EVF SET]

☼ :Brightness of the viewfinder

3 Move the joystick left or right to move the bar indication representing the brightness.

4 Press the [MENU] button or the joystick to complete the settings.

- When the LCD monitor is rotated by 180° towards the lens, the brightness of the LCD monitor cannot be adjusted.
- To adjust the brightness of the viewfinder, close the LCD monitor and extend the viewfinder to activate it.
- These settings will not affect the images actually recorded.

### ■ In order to increase the brightness of the entire LCD monitor

1 Set [SETUP] >> [POWER LCD] >> [ON].

- The [☼] indication appears on the LCD monitor.
- If the [POWER LCD] is set to [ON], the entire LCD monitor will become approx. twice as bright as the normal.

- 
- To cancel the [POWER LCD] function, set [SETUP] >> [POWER LCD] >> [OFF].
  - This will not affect the images to be recorded.
  - If you turn on the camera when the AC adaptor is used, the [POWER LCD] function will automatically be activated.
  - You cannot use this function in PC Connection Mode.

## Using the remote control

### Remote control

Using the remote control supplied will enable controlling almost all the functions of this camera to be controlled.

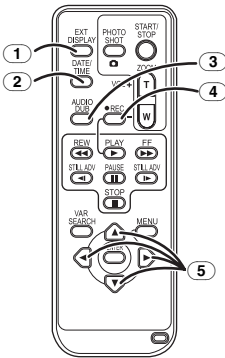

- ① On-screen display button [EXT DISPLAY] -41-
- ② Date/time button [DATE/TIME] -65-
- ③ Audio dubbing button [AUDIO DUB] -47-
- ④ Record button [●REC] -46-
- ⑤ Direction buttons [▲, ◀, ▶, ▼] -20-

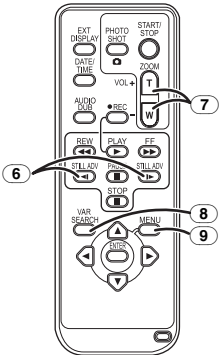

- ⑥ Slow/frame-by-frame forward button [◀1, ▶1] (◀1: reverse, ▶1: forward) -40-
- ⑦ Zoom/volume button [ZOOM/VOL] \*
- ⑧ Search button [VAR SEARCH] -40-
- ⑨ Menu button [MENU] \* -20-

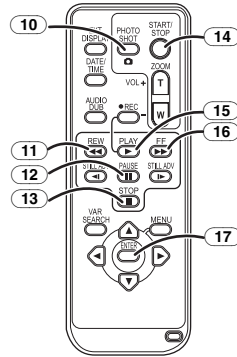

- ⑩ Photoshot button [PHOTO SHOT] \*
- ⑪ Rewind/review button [◀◀]
- ⑫ Pause button [||]
- ⑬ Stop button [■]
- ⑭ Recording start/stop button [START/STOP] \*
- ⑮ Playback button [PLAY ▶]
- ⑯ Fast forward/cue button [▶▶]
- ⑰ Enter button [ENTER] -20-

\* means that these buttons function in the same manner as the corresponding buttons on the movie camera.

### Install a button-type battery

Install the button-type battery supplied in the remote control before using it.

- 1 While pressing the stopper ①, pull out the battery holder.

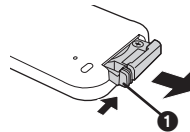

- 2 Set the button-type battery with its (+) mark facing upward and get the battery holder back in place.

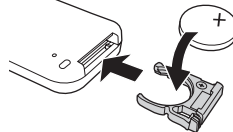

### CAUTION

Danger of explosion if battery is incorrectly replaced. Replace only with the same or equivalent type recommended by the manufacturer. Dispose of used batteries according to the manufacturer's instructions.

### Warning

Keep the Button-Type battery out of the reach of children. Never put Button-Type battery in mouth. If swallowed call your doctor.

## Remote control usable range

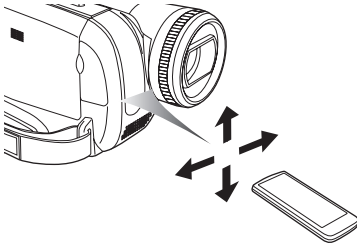

- The distance between the remote control and the camera: Within approx. 5 m  
Angle: Approx. 10° up and 15° down, left, and right

## Selecting the remote control mode

If 2 cameras are used simultaneously, set the mode for one pair of movie camera and remote control to [VCR1] and that of the other pair to [VCR2]. This will prevent interference between the 2 pairs. (The default setting is [VCR1].) When the button-type battery is replaced, the setting will revert to the default [VCR1].)

### 1 Setting on the camera:

Set [SETUP] >> [REMOTE] >> [VCR1] or [VCR2].

### 2 Setting on the remote control:

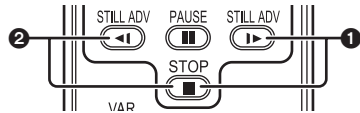

[VCR1]:

Press [▶] and [■] simultaneously. ①

[VCR2]:

Press [◀] and [■] simultaneously. ②

## Concerning the button-type battery

- When the button-type battery runs down, replace it with a new battery (part number: CR2025). The battery is normally expected to last about 1 year, but it depends on operation frequency.
  - Keep the button-type battery out of the reach of children.
- 
- If the remote control mode of the camera and that of the remote control do not match with each other, "REMOTE" will appear. When the remote control is operated for the first time after the camera is turned on, "CHECK REMOTE MODE" (-67-) will appear and operation is impossible. Set the same remote control mode.
  - The remote control is intended for indoor operation. Outdoors or under strong light, the movie camera may not operate properly even within the usable ranges.

## Record mode

### Check before recording

Check the following before recording important events such as weddings or when the movie camera has not been used for a long time. Conduct a test recording to make sure that the image recording and the audio recording work properly.

#### Basic camera holding

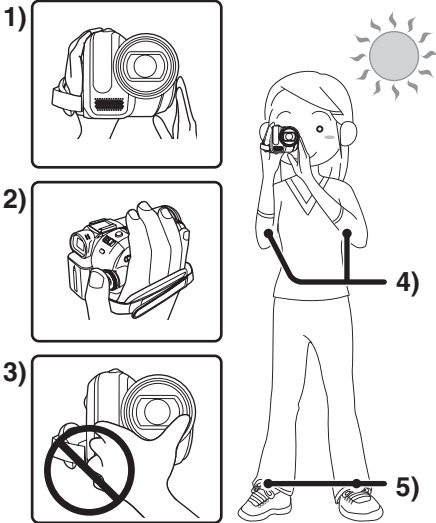

- 1) Hold the camera with both hands.
- 2) Run your hand through the grip belt.
- 3) Do not cover the microphones or sensors with your hands.
- 4) Keep your arms near your body.
- 5) Slightly open your legs.

- When you are in the open air, record pictures with the sunlight as far in the background as possible. If the subject is backlit, it will become dark in the recording.

#### Check points

- Remove the lens cap. (-8-)  
(When the camera is turned on with the lens cap fitted, the automatic white balance adjustment may not function properly. Please turn the camera on after removing the lens cap.)
- Grip belt adjustment (-9-)
- Open the LCD monitor or extend the viewfinder.  
(Recording cannot start while the LCD monitor and viewfinder are closed. Even if the LCD monitor and viewfinder are closed during recording, the power will not turn off until recording stops.)
- Adjusting LCD monitor/viewfinder (-21-)

- Power supply (-9-)
- Insert a cassette/card (-15-, -16-)
- Setting date/time (-12-)
- Getting the remote control ready (-22-)
- Setting SP/LP mode (-24-)

#### About auto mode

- Set the [AUTO/MANUAL/FOCUS] switch to [AUTO], and colour balance (white balance) and focusing will be adjusted automatically.
  - Auto white balance: -76-
  - Auto focusing: -77-
- Depending on the brightness of the subject etc., the aperture and shutter speed are automatically adjusted for an optimum brightness. (When set to the Tape recording mode: The shutter speed is adjusted to a maximum of 1/250.)
- Colour balance and focus may not be adjusted depending on light sources or scenes. If so, manually adjust the white balance and focus.

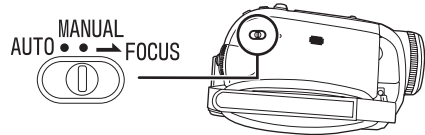

- Scene mode setting (-35-)
- White balance setting (-36-)
- Shutter speed setting (-38-)
- Iris/gain value setting (-38-)
- Focus setting (-37-)

#### Recording mode

You can switch the tape recording mode.

- Set to Tape Recording/Playback Mode.

1 Set [BASIC] or [ADVANCED] >> [REC SPEED] >> [SP] or [LP].

If the LP mode is selected, the recording time will be 1.5 times the SP mode, but some functions will be disabled.

- We recommend using the SP mode for important recording.
- In order to fully exhibit the performances of the LP mode, we recommend using Panasonic cassettes marked LP mode.
- It is not possible to dub audio onto image recorded in the LP mode. (-47-)
- In the LP mode, the picture quality will not be degraded in comparison with the SP mode, but mosaic noise may appear on the playback image or some functions may be disabled.
  - Playback on other digital video equipment or on digital video equipment without the LP mode.
  - Playback of the image on other digital video equipment recorded in the LP mode.
  - Slow/frame-by-frame playback.



## Recording on a tape

### Remove the lens cap. (-8-)

(When the camera is turned on with the lens cap fitted, the automatic white balance adjustment may not function properly. Please turn the camera on after removing the lens cap.)

When this unit is purchased, the aspect ratio is set to [16:9] for recording images compatible with a wide-screen TV. To make this unit compatible with regular TVs (4:3), change the [REC ASPECT] setting before recording the images (-34-) or change the [TV ASPECT] setting when watching them on the connected TV (-41-).

### ● Set to Tape Recording Mode.

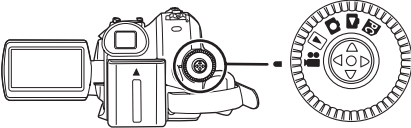

**1 Press the recording start/stop button to start recording.**

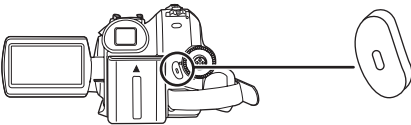

**2 Press the recording start/stop button again to pause recording.**



- For the recording time on a tape, refer to -11-.
- Carry out a recording check (-26-) to verify that the image is recorded properly.
- In order to find the unrecorded section, carry out the blank search (-26-).
- If you want to preserve the original sound recorded when audio dubbing (-47-), set [ADVANCED] >> [AUDIO REC] >> [12bit] to take pictures.

## ■ On-screen display in the tape recording mode

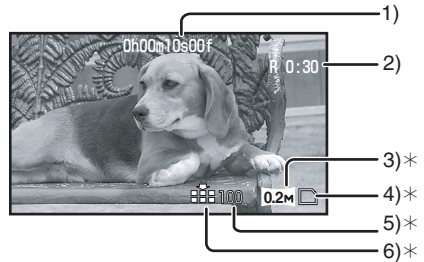

\* These are only displayed when you press the [ ] button half way while a card is inserted. These are not displayed when using the remote control.

- 1) Recording time elapse
- 2) Remaining tape indication
- 3) Still picture size
- 4) Card indication (-66-)
- 5) Number of recordable still pictures (When no picture can be recorded, this indication will flash in red.)
- 6) Quality of still pictures

## ■ Concerning the remaining tape time indication on the screen

- The remaining tape time is indicated in minutes. (When it reaches less than 3 minutes, the indication starts flashing.)
- During a 15-second or shorter recording, the remaining tape time indication may not be displayed or the remaining tape time may not be displayed correctly.
- In some cases, the remaining tape time indication may display remaining tape time that is 2 to 3 minutes shorter than the actual remaining tape time.

## Recording check

The last image recorded is played back for 2 to 3 seconds. After checking, the camera will be set to a recording pause.

### ● Set to Tape Recording Mode.

- 1 Press the joystick to display the icon during the recording pause. Move the joystick down until icon ❶ appears.
- 2 Move the joystick left to select the recording check icon [⏮].



- The [RECORDING CHECK STARTED] indication appears on the screen of the movie camera.

## Blank search function

Searches for the last part of the image recorded (unused part of the tape). After the search is finished, the blank search function is cancelled and the camera is put into recording pause.

### ● Set to Tape Recording Mode.

- 1 Press the joystick to display the icon during the recording pause. Move the joystick down until icon ❶ appears.
- 2 Move the joystick right to select the blank search icon [⏪].



- 3 When the confirmation message appears, select [YES] and press the centre of the joystick.

### ■ Stopping blank search midway through

Move the joystick down to select the [■] icon.

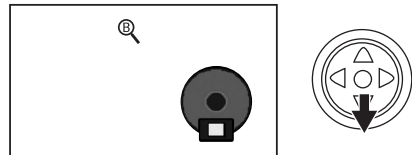

- If the cassette tape has no blank part, then the camera will stop at the end of the tape.
- The camera stops at a point approx. 1 second before the end of the last image recorded. When you start recording at that point, the image can be recorded seamlessly from the last image.

## Recording still pictures on a card while recording image onto a tape

You can record still pictures while recording image onto a tape.

### ● Set to Tape Recording Mode.

1 Press the [  ] button fully while recording image onto a tape.

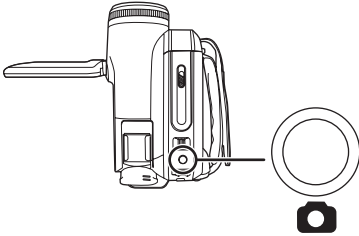

- For the number of still pictures to be recorded on a card, refer to -79-.
- When recording pictures onto a card, the recording start/stop button is disabled.
- You can select a picture quality for still pictures to be recorded. (-28-)
- In order to record still pictures with higher quality, we recommend using the Card recording mode.
- When recording still pictures, hold the movie camera firmly with your hands and keep your arms stationary at your side so as not to shake the movie camera.

### ■ Select the size of still pictures to be recorded on a card in Tape Recording Mode

1 Set [ADVANCED] >> [PICTURE SIZE] >> select the desired picture size.

REC ASPECT [16:9]:

: 1280×720

: 640×360

REC ASPECT [4:3]:

: 1280×960

: 640×480

## Recording still pictures onto a card (Photoshot)

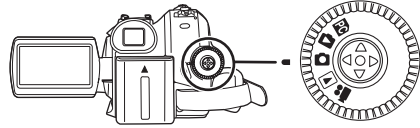

### ● Set to Card Recording Mode.

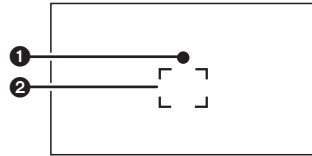
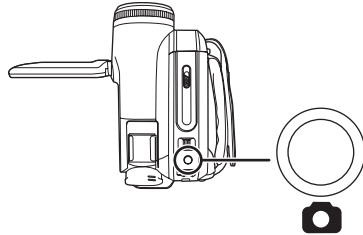

1 Press the [  ] button halfway in order to adjust focusing. (For auto focusing only)

- If you set [O.I.S.] to [ON], then the image stabilizer function will be more effective. ([MEGA] (MEGA OIS)) will be indicated.)
- The iris/gain value is fixed and this camera focuses on the subject automatically.



- ① Shutter chance mark
    - (The white lamp flashes.): Focusing
    - (The green lamp lights up.): When in focus
  - No mark: When focusing is unsuccessful
  - The shutter chance mark is indicated as follows when the [  ] button is not pressed halfway. Please use it as a guide for recording.
    - (The green lamp lights up.): When in focus and a good picture can be recorded
    - (The white lamp lights up.): Almost in focus
  - ② Focus area
- 2 Press the [  ] button fully.

## ■ To record still pictures clearly

- When zooming in on the subject with a magnification of 4× or higher, it is difficult to reduce the slight shaking from holding the movie camera by hand. We recommend decreasing the zoom magnification and approaching the subject when recording.
- When recording still pictures, hold the movie camera firmly with your hands and keep your arms stationary at your side so as not to shake the movie camera.
- You can record stable pictures without shaking by using a tripod and the remote control.

- For the number of still pictures to be recorded on a card, refer to -79-.
- The moving picture and sound cannot be recorded.
- While data are recorded on a card, do not operate the mode dial.
- When the access lamp is lit, do not insert or remove a card.
- Another product may degrade or not play back data recorded on this camera.
- If set [PICT.QUALITY] >> [..], mosaic-pattern noise may appear on a playback image depending on the picture content.
- When the [PICTURE SIZE] is set to other than [0.2M] or [0.3M], the mega pixel recording mode is set.
- It is not possible to press the [PHOTO SHOT] button on the remote control halfway.

## ■ On-screen display in the card recording mode

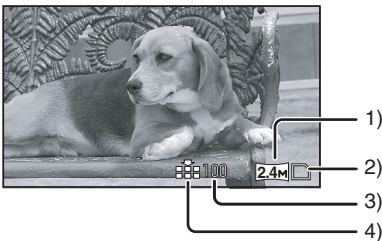

- 1) Still picture size
- 2) Card indication (-66-)
- 3) Number of recordable still pictures (When no picture can be recorded, this indication will flash in red.)
- 4) Quality of still pictures

## ■ Select the size of still pictures to be recorded on a card

- 1 Set [BASIC] >> [PICTURE SIZE] >> select the desired picture size.

REC ASPECT [16:9]:

[2.4M]: 2048×1152

[0.2M]: 640×360

REC ASPECT [4:3]:

[3.1M]: 2048×1512

[2M]: 1600×1200

[1M]: 1280×960

[0.3M]: 640×480

- When you purchase this unit, [REC ASPECT] is set to [16:9]. The sides of pictures recorded when [16:9] is set may be cut at printing. Check before printing.

## ■ Select the picture quality for photoshot images

- 1 Set [BASIC] >> [PICT.QUALITY] >> select the desired picture quality.

[...]: High picture quality

[...]: Normal picture quality

- You can also change the picture quality on [ADVANCED] >> [PICT.QUALITY] in the tape recording mode.

## ■ Recording with a shutter operation effect

You can add a shutter operation simulating sound.

- 1 Set [ADVANCED] >> [SHTR EFFECT] >> [ON].

## ■ About the shutter chance mark

- The shutter chance mark does not appear in manual focus mode.
- When the subject is not easily focused, focus on the subject manually.
- You can record still pictures on the card even if the shutter chance mark does not appear, but pictures may be recorded without being focused.
- The shutter chance mark does not appear or becomes difficult to be displayed in the following cases.
  - When the zoom magnification is high.
  - When the movie camera is shaken.
  - When the subject is moving.
  - When the subject stands against the light source.
  - When close subjects and far subjects are included in the same scene.
  - When the scene is dark.
  - When there is a bright part in the scene.
  - When the scene is filled with only horizontal lines.

- When the scene lacks contrast.
- When recording on tape.

### Concerning the focusing area

- When there is a contrasting object ahead or behind the subject in the focus area, the subject may not be focused. If so, move the contrasting object out of the focus area.
- Even when it is still difficult to focus, adjust the focus manually.

### Zoom in/out function

You can zoom in up to 10X optically.

#### Set to Tape/Card Recording Mode.

##### 1 Wide-angle recording (zoom out):

Push the [W/T] lever towards [W].

Close-up recording (zoom in):

Push the [W/T] lever towards [T].

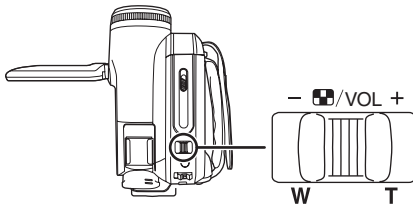

- When zooming in and taking a picture while holding the movie camera by hand, we recommend using the image stabilizer function.
- When you are zooming on a faraway subject, a sharper focus is achieved if the recording subject is 1.0 metre or further from the movie camera.
- When the zoom speed is high, the subject may not be focused easily.
- When the zoom magnification is 1X, the movie camera can focus on a subject approx. 4.0 cm distant from the lens.
- Be aware that a mechanical sound may be recorded when the [W/T] lever is released while zooming. Gently move the zoom lever back to its original position before releasing it.

### Digital zoom function

If the zoom magnification exceeds 10 times, then the digital zoom function will be activated. The digital zoom function allows you to select a magnification from 25X to 700X.

#### Set to Tape Recording Mode.

1 Set [ADVANCED] >> [D.ZOOM] >> [25X] or [700X].

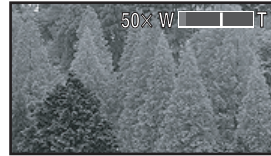

[OFF]: Optical zoom only (Up to 10X)

[25X]: Digital zoom (Up to 25X)

[700X]: Digital zoom (Up to 700X)

- The larger the digital zoom magnification, the more the image quality is degraded.
- When the Card Recording mode is used, the digital zoom function cannot be used.

### About the variable speed zoom function

- The zoom speed varies according to the amount of movement of the [W/T] lever.
- The variable speed zoom function cannot be used with the remote control.

### To use the zoom microphone function

Interlocked with the zooming operation, the microphone will collect sounds clearly far away with the tele-shot or those in the vicinity with the wide-angle shot.

#### Set to Tape Recording Mode.

1 Set [ADVANCED] >> [ZOOM MIC] >> [ON].



## Recording yourself

You can record yourself while viewing the LCD monitor. You can record persons in front of the camera while presenting them the image. The image is horizontally flipped as if you see a mirror image. (However the image to be recorded is not altered.)

- **Extend the viewfinder to see the picture while recording.**

**1 Rotate the LCD monitor towards the lens side.**

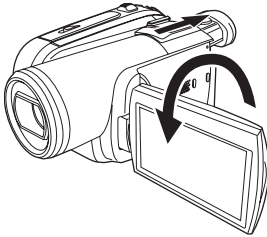

- When the Wide function is set, a vertically oriented display appears on the viewfinder screen, this is normal and not indicative of any trouble.
- When the LCD monitor is rotated towards the lens side, the icon will not be displayed even if you push the centre of the joystick.

## Backlight compensation function

This protects a backlit subject from being darkened.

- **Set to Tape/Card Recording Mode.**

**1 Press the joystick to display the icon. Move the joystick down until icon ① appears.**

**2 Move the joystick up to select the backlight compensation icon [B.C.].**

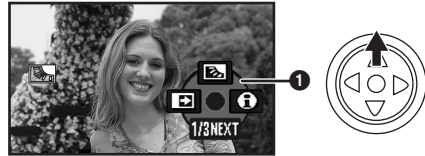

- The [BACKLIGHT COMPENSATION ON] indication appears on the screen of the movie camera.
- The image on the screen will become brighter.

### ■ To return to normal recording

Select the [B.C.] icon again.

- The [BACKLIGHT COMPENSATION OFF] indication appears on the screen of the movie camera.
- 
- The backlight compensation function is cancelled when you turn off the power or operate the mode dial.
  - The backlight compensation is cancelled when you activate the colour night view function.

## Colour night view function

This function allows you to record colour subjects in dark locations to stand out against the background.

Attach the camera to a tripod, and you can record images free from vibration.

- Recorded scene is seen as if frames were missed.

### ● Set to Tape Recording Mode.

1 Press the joystick to display the icon. Move the joystick down until icon ❶ appears.

2 Move the joystick up to select the colour night view icon [🌙].

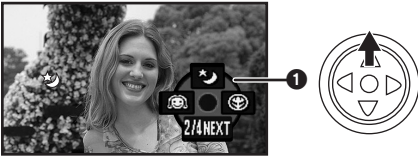

- The [COLOUR NIGHT VIEW ON] indication appears on the screen of the movie camera.
- If it is difficult to focus, adjust the focus manually. (-37-)

### ■ To cancel the colour night view function

Select the [🌙] icon again.

- The [COLOUR NIGHT VIEW OFF] indication appears on the screen of the movie camera.

- If set in a bright place, the screen may become whitish for a while.
- The colour night view function makes the signal charging time of the CCD up to approximately 25× longer than usual, so that dark scenes (a minimum of 1 lx) can be recorded brightly. For this reason, bright dots that are usually invisible may be seen, but this is not a malfunction.
- The colour night view function is cancelled when you turn off the power or operate the mode dial.

## Soft skin mode

This allows the skin colour to be recorded in a softer tone. This is more effective if you record the best image of a person.

### ● Set to Tape/Card Recording Mode.

1 Press the joystick to display the icon. Move the joystick down until icon ❶ appears.

2 Move the joystick left to select the soft skin icon [👤].

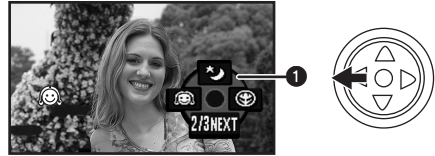

- The [SOFT SKIN MODE ON] indication appears on the screen of the movie camera.

### ■ To cancel the soft skin mode

Select the [👤] icon again.

- The [SOFT SKIN MODE OFF] indication appears on the screen of the movie camera.

- If the background or anything else in the scene has colours similar to the skin colour, they will also be smoothed.
- If the brightness is insufficient, the effect may not be clear.

## Tele macro function

By focusing only on the subject and blurring the background, the image can be impressive. This camera can focus on the subject at a distance of approx. 50 cm.

● **Set to Tape/Card Recording Mode.**

- 1 Press the joystick to display the icon. Move the joystick down until icon ❶ appears.
- 2 Move the joystick right to select the tele macro icon [📷].



- The [TELE MACRO ON] indication appears on the screen of the movie camera.
- If the magnification is 10× or less, then it is automatically set to 10×.

### ■ To cancel the tele macro function

Select the [📷] icon again.

- The [TELE MACRO OFF] indication appears on the screen of the movie camera.
- 
- If a sharper focus cannot be achieved, adjust the focus manually.
  - In the following cases, the tele macro function is cancelled.
    - The zoom magnification becomes lower than 10×.
    - The power is off or the mode dial is operated.

## Fade in/fade out function

### Fade in

The image and audio gradually appear.

### Fade out

The image and audio gradually disappear.

● **Set to Tape Recording Mode.**

- 1 Press the joystick to display the icon. Move the joystick down until icon ❶ appears.
- 2 Move the joystick left to select the fade icon [📷].

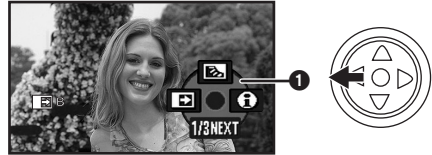

- The [FADE ON] indication appears on the screen of the movie camera.

### 3 Press the recording start/stop button.

#### Start recording. (fade in)

When you start recording, the image/audio disappeared completely and the image/audio gradually appears.



#### Pause recording. (fade out)

The image/audio gradually disappears. After the image/audio completely disappears, recording stops.





**To cancel fading**

Select the [ ] icon again.

- The [FADE OFF] indication appears on the screen of the movie camera.

**To select the colour for fade in/out**

The colour which appears in fading pictures can be selected.

1 Set [ADVANCED] >> [FADE COLOUR] >> [WHITE] or [BLACK].

- While the fade in/fade out function is selected, it takes several seconds to display the image when you start recording images. Besides, it also takes several seconds to pause recording.

**Wind noise reduction function**

This reduces the wind noise coming into the microphone when recording.

**Set to Tape Recording Mode.**

1 Set [BASIC] >> [WIND CUT] >> [ON].

**To cancel the wind noise reduction function**

Set [BASIC] >> [WIND CUT] >> [OFF].

- The default setting is [ON].
- Reduces the wind noise depending on the wind strength. (If this function is activated in strong winds, the stereo effect may be reduced. When the wind weakens, the stereo effect will be restored.)

**Anti-Ground-Shooting (AGS)**

This function prevents unnecessary recording when you forget to pause recording and walk with the camera tilted upside down while recording continues.

- If the movie camera continues to be tilted upside down from the normal horizontal position while recording on a tape, it is automatically put into recording pause.



AGS: Anti-Ground-Shooting

**Set to Tape Recording Mode.**

1 Set [SETUP] >> [AGS] >> [ON].

**To cancel Anti-Ground-Shooting**

Set [SETUP] >> [AGS] >> [OFF].

- The AGS function may activate and cause the movie camera to pause the recording if you are recording a subject right above or right below you. In these cases, set [AGS] >> [OFF] then continue the recording.
- Use the recording start/stop button to pause or stop the recording. The AGS function is only a backup function for when you forget to pause the recording.
- The time it takes the camera to be put into recording pause after being tilted upside down varies depending on the operating conditions.

## Self-timer recording

You can record still pictures on a card using the timer.

### ● Set to Card Recording Mode.

- 1 Press the joystick to display the icon. Move the joystick down until icon ① appears.
- 2 Move the joystick left to select the self-timer recording icon [⌚].

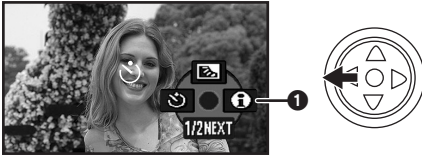

- The [SELF-TIMER ON] indication appears on the screen of the movie camera.

- 3 Press the [⏻] button.

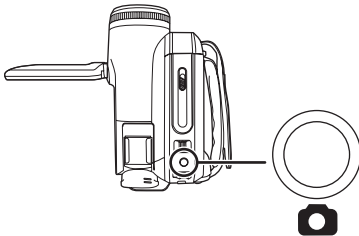

- After the [⌚] indication flashes for approx. 10 seconds, recording will start. After recording, the self-timer will be cancelled.
- If you press the [⏻] button halfway and then fully, the subject is focused when the button is pressed halfway.
- When you press the [⏻] button fully, the subject is focused just before recording.

### ■ To stop the timer midway through

Press the [MENU] button.

- The self-timer standby mode is cancelled when you turn off the power or operate the mode dial.

## Wide/4:3 Function

This allows you to record images compatible with wide-screen TVs.

### Wide Function

Images are recorded with a 16:9 aspect ratio.

### 4:3 Function

Images are recorded with a 4:3 aspect ratio.

### ● Set to Tape/Card Recording Mode.

#### 1 Wide Function

Set [BASIC] >> [REC ASPECT] >> [16:9].

#### 4:3 Function

Set [BASIC] >> [REC ASPECT] >> [4:3].

### ■ To Cancel the Wide/4:3 Function

#### Wide Function

Set [BASIC] >> [REC ASPECT] >> [4:3].

#### 4:3 Function

Set [BASIC] >> [REC ASPECT] >> [16:9].

- The default setting is [16:9].
- In the wide-screen mode, the menu screens, operation icons and other screen displays appear horizontally oriented.
- When images are played back on a TV screen, the date/time indication may be erased in some cases.
- Depending on the TV, the picture quality may deteriorate.
- If still pictures recorded with a 4:3 aspect ratio are played back when [TV ASPECT] is set to [16:9], part of the operation icons and other displays will appear on the black bands on the left and right of the picture.
- Concerning the TV to be connected and TV used for playback.
  - When playing back images taken by this unit on a TV screen, change the setting established by Tape/Card playback mode [SETUP] >> [TV ASPECT] to match the aspect ratio (4:3 or 16:9) of the TV monitor to be connected. (-41-)
  - Depending on the settings of the TV connected, the images may not be displayed properly. For more information, please read the operating instructions for the TV.

## Image stabilizer function

Reduces the image shaking due to hand movement when recording.

- **Set to Tape/Card Recording Mode.**
- 1 Set [ADVANCED] >> [O.I.S.] >> [ON].



### ■ To cancel the image stabilizer function

Set [ADVANCED] >> [O.I.S.] >> [OFF].

- When recording still pictures in the Card Recording mode, pressing the [ ] button halfway increases the effect of the image stabilizer function. (MEGA OIS)
- In the following cases, the image stabilizer function may not work effectively.
  - When the digital zoom is used
  - When a conversion lens is used
  - When the camera is shaken greatly
  - When you record a moving subject while tracking it

## Guideline function

View the slope and the balance of the image while recording.

You can check if the image is level while recording motion pictures. The function can also be used to estimate the balance of the composition.

- **Set to Tape/Card Recording Mode.**
- 1 Set [ADVANCED] >> [GUIDE LINES] >> [ON].



### ■ To Cancel the Guideline Function

Set [ADVANCED] >> [GUIDE LINES] >> [OFF].

- The guide lines do not appear on the images actually recorded.

## Recording in various situations (Scene mode)

When you record images in different situations, this mode automatically sets optimum shutter speeds and apertures.

- **Set to Tape/Card Recording Mode.**

- 1 Set the [AUTO/MANUAL/FOCUS] switch to [MANUAL].

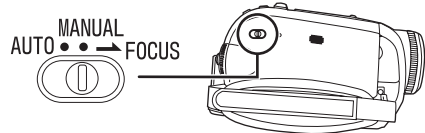

- 2 Set [BASIC] >> [SCENE MODE] >> select the desired mode.

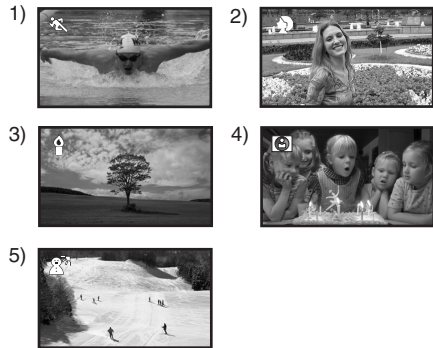

- 1) [ ] **Sports mode**
  - To record sports scenes or scenes where there are quick motions
- 2) [ ] **Portrait mode**
  - To make persons stand out against the background
- 3) [ ] **Low light mode**
  - To record dark scenes so they are brighter
- 4) [ ] **Spotlight mode**
  - To record subjects spotlighted in a party or theatre
- 5) [ ] **Surf & snow mode**
  - To record images at dazzling places such as ski slopes and beaches

### ■ To cancel the scene mode function

Set [BASIC] >> [SCENE MODE] >> [OFF] or set the [AUTO/MANUAL/FOCUS] switch to [AUTO].

### Sports mode

- For slow-motion playback or playback pause of recorded pictures, this mode presents free of camera shakes.
- During normal playback, the image movement may not look smooth.
- Avoid recording under fluorescent light, mercury light or sodium light because the colour and brightness of the playback image may change.
- If you record a subject illuminated with strong light or a highly reflective subject, vertical lines of light may appear.
- If the brightness is insufficient, the sports mode does not function. The [  ] indication flashes.
- If this mode is used indoors, the screen may flicker.

### Portrait mode

- If this mode is used indoors, the screen may flicker. If so, change the scene mode setting to [OFF].

### Low light mode

- Extremely dark scenes may not be able to be recorded finely.

### Spotlight mode

- If the recording subject is extremely bright, the recorded image may become whitish and the periphery of the recorded image extremely dark.

### Surf & snow mode

- If the recording subject is extremely bright, the recorded image may become whitish.

## Recording in natural colours (White balance)

The automatic white balance function may not reproduce natural colours depending on the scenes or lighting conditions. If so, you can adjust the white balance manually.

### ● Set to Tape/Card Recording Mode.

- 1 Set the [AUTO/MANUAL/FOCUS] switch to [MANUAL].

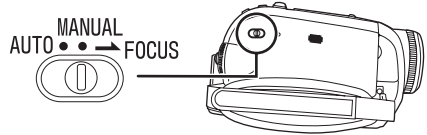



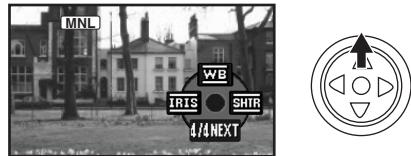

- 2 Move the joystick up to select the white balance icon [WB].

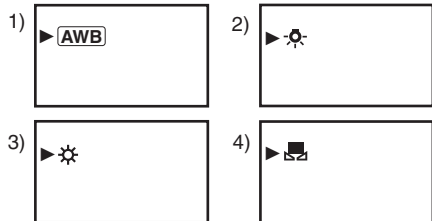

- 3 Move the joystick left or right in order to select the white balance mode.





- 1) Auto white balance adjustment [  ]
- 2) Indoor mode (for recording under incandescent lamps) [  ]
- 3) Outdoor mode [  ]
- 4) Manual adjustment mode [  ]

### ■ To restore to the automatic adjustment

Move the joystick left or right until the [  ] indication appears. Or, set the [AUTO/MANUAL/FOCUS] switch to [AUTO].

- When the camera is turned on with the lens cap fitted, the automatic white balance adjustment may not function properly. Please turn the camera on after removing the lens cap.
- When setting both the white balance and the iris/gain, set the white balance first.
- Whenever recording conditions change, re-set the white balance for correct adjustment.

### ■ To set the white balance manually

Select [  ] in Step 3. Then, while viewing a white subject on the entire screen, move the joystick up to select the [  ] indication.

### ■ About flashing of the [ ] indication When the manual adjustment mode is selected

- Flashing indicates that the white balance previously adjusted is stored. This setting is stored until the white balance is adjusted again.

### When white balance cannot be set in the manual adjustment mode

- White balance may not be adjusted properly in the manual adjustment mode in dark places. If so, use the auto white balance mode.

### During setting in the manual adjustment mode

- When the setting is completed, it will keep lit.

### ■ About the white balance sensor

The white balance sensor detects the type of light source during recording.

- Do not cover the white balance sensor during recording, or it may not function properly.

### ■ About the black balance adjustment

This is one of the 3CCD system functions that automatically adjusts the black when the white balance is set in the manual adjustment mode. When the black balance is being adjusted, the screen will temporarily be black. (It is not possible to adjust the black sensor manually)

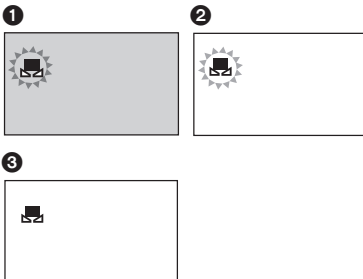

- 1 Black balance adjustment (Flashes.)
- 2 White balance adjustment (Flashes.)
- 3 Adjustment completed (Lights up.)

## Manual focus adjustment

If auto focusing is difficult due to the conditions, then manual focusing is available.

### ● Set to Tape/Card Recording Mode.

- 1 Set the [AUTO/MANUAL/FOCUS] switch to [MANUAL].

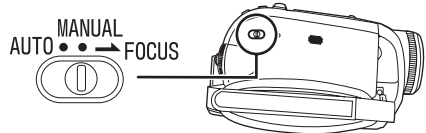

- 2 Set the [AUTO/MANUAL/FOCUS] switch to [FOCUS].

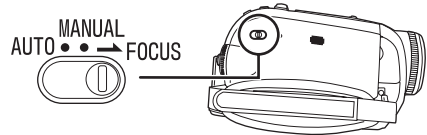

- The [  ] indication and the manual focus [MF] indication is displayed.

- 3 Move the joystick left or right in order to adjust the focus.



- When focused with a wide angle, the subject may not be in focus when zoomed in. First, zoom in on the subject, and then focus on it.

### ■ To restore to the automatic adjustment

Set the [AUTO/MANUAL/FOCUS] switch to [AUTO] or [FOCUS].

## Manual shutter speed/aperture adjustment

### Shutter Speed

Adjust it when recording fast-moving subjects.

### Aperture

Adjust it when the screen is too bright or too dark.

#### ● Set to Tape/Card Recording Mode.

1 Set the [AUTO/MANUAL/FOCUS] switch to [MANUAL].

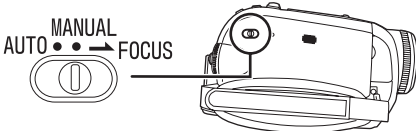

2 Move the joystick left or right to select the aperture icon [IRIS] or shutter speed icon [SHTR].



3 Move the joystick left or right in order to adjust the shutter speed or aperture.

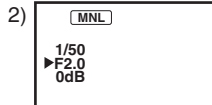
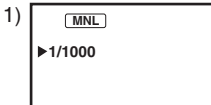

1) Shutter speed

2) (Aperture) Iris/gain value

#### ■ To restore to automatic adjustment

Set the [AUTO/MANUAL/FOCUS] switch to [AUTO].

### Manual shutter speed adjustment

- Avoid recording under fluorescent light, mercury light or sodium light because the colour and brightness of the playback image may change.
- If you increase the shutter speed manually, the sensitivity lowers and accordingly the gain value increases automatically, which may increase the noises on the screen.
- You may see vertical lines of light in the playback image of a brightly shining subject or highly reflective subject, but this is not a malfunction.
- During normal playback, image movement may not look smooth.
- When recording in the extremely bright place, the colour of the screen may change or flickers. If so adjust the shutter speed manually to 1/50 or 1/100.

### Manual iris/gain adjustment

- Set the shutter speed before setting the aperture (iris/gain) when manually adjusting both settings.
- If the value does not become "OPEN", you cannot adjust the gain value.
- If the gain value is increased, the noise on the screen increases.
- Depending on the zoom magnification, there are iris values that are not displayed.

#### ■ Shutter speed range

1/50 to 1/8000 seconds: Tape Recording Mode

1/25 to 1/2000 seconds: Card Recording Mode

The shutter speed closer to 1/8000 is faster.

#### ■ Iris/gain value range

CLOSE (Closed), F16, ..., F2.0,

OPEN (Opened: F1.8) 0dB, ..., 18dB

Value closer to [CLOSE] darken the image.

Value closer to [18dB] brighten the image.

Values with dB are gain values.

## Playback mode

### Playing back tape

- Set to Tape Playback Mode.  
(An operation icon automatically appears on the LCD monitor.)

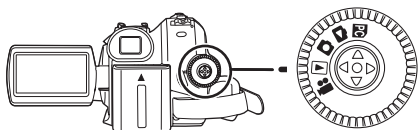

#### 1 Operate with joystick.

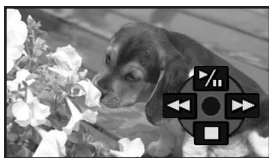

- ▶/||: Playback/Pause
- ◀◀: Rewind/Review playback (Reverts to playback with the ▶/|| icon.)
- ▶▶: Fast forward/Cue playback (Reverts to playback with the ▶/|| icon.)
- : Stop

- The power will not turn off when the LCD monitor and the viewfinder are closed and retracted during Tape/Card playback mode.
- During cue/review playback, fast-moving images may show noise as a mosaic.
- Before and after cue/review playback, the screen may become black for a moment or images may be disturbed.

### ■ To adjust volume

Adjust the speaker volume for playback.

- 1 Move the [- VOL+] lever to adjust the volume.

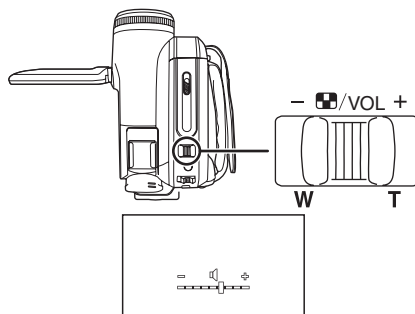

Towards [+]: increases the volume  
Towards [-]: decreases the volume  
(Nearer the bar to [+], larger the volume.)

- On the remote control, press the [T] button to increase the volume or the [W] button to decrease it.
- When the adjustment is completed, the volume indication will disappear.
- If you do not hear the sound, check the settings of [SETUP] >> [12bit AUDIO].

### ■ Repeat playback

When the tape end is reached, the tape will be rewound and played back again.

- 1 Set [ADVANCED] >> [REPEAT PLAY] >> [ON].

- The [REPEAT] indication appears. (In order to cancel the repeat playback mode, set [REPEAT PLAY] >> [OFF] or turn off the power.)
- When you set [USB FUNCTION] >> [WEBCAM] and then connect the USB cable, the repeat playback mode is cancelled.

### ■ Settings on the audio

- If you cannot listen to the desired audio when playing back a tape, check the settings in [SETUP] >> [12bit AUDIO].
- When you record and dub the audio in [12bit] and set [SETUP] >> [12bit AUDIO] >> [MIX], the audio will be played back in stereo sound regardless of the settings in [AUDIO OUT].

## Slow-motion playback/ frame-by-frame playback

- Set to Tape Playback Mode. (Slow-motion playback can only be performed by using the remote control.)

### Slow-motion playback

If the image is recorded in the SP mode, then it will be played back at a speed approx. 1/5 the normal speed.

If the image is recorded in the LP mode, then it will be played back at a speed approx. 1/3 the normal speed.

- 1 Press the [◀] button or the [▶] button on the remote control.

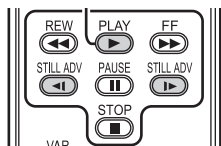

- If the slow-motion playback continues for approx. 10 minutes or more, then the playback will automatically stop. (10 minutes of slow-motion playback is equivalent to approx. 2 minutes in the SP mode or approx. 3 minutes in the LP mode.)

### Frame-by-frame playback

- 1 During playback, press the [||] button on the remote control.
- 2 Press the [◀] button or the [▶] button on the remote control.

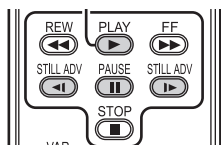

- Pushing the [-] / VOL+ lever towards [T] (normal direction) or towards [W] (reversed direction) of this camera during playback pause also turns into the frame-by-frame playback. If you keep pushing the lever, then the images will continuously be played back frame by frame.

- The pause icon appears for an instant. Continuous frame-by-frame playback will start after the pause icon disappears.

### ■ To return to normal playback

Press the [PLAY ▶] button on the remote control or move the joystick up to the [▶] icon to start playback.

### Slow-motion playback

- In the reversed slow-motion playback, the time code indication may be unstable.

### Frame-by-frame playback

- Press and hold the [◀] or the [▶] button in the playback pause, and then the images will continuously be played back frame by frame.

## Variable-speed search function

The speed of cue/review playback can be varied. (This operation is only available when using the remote control.)

- Set to Tape Playback Mode and play back a tape.

- 1 Press the [VAR SEARCH] button on the remote control.



- 2 Press the [▲] or [▼] button to vary the speed.

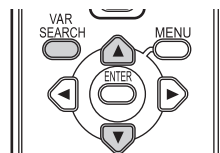

- The speeds for cue/review playback are 1/5× (SP mode slow-motion playback only), 1/3× (LP mode slow-motion playback only), 2×, 5×, 10×, 20×.

### ■ To return to normal playback

Press the [VAR SEARCH] button or [PLAY ▶] button on the remote control.

- Images may be shown in a mosaic-like pattern.
- The sound is muted during search.
- This function is cancelled when the operation icon is displayed.
- When you cue/review playback at 20×, the speed switches to 10× near both ends of the tape. ([10×] flashes on the screen.)



## Playback on TV

Images recorded by this camera can be played back on a TV.

- Insert a recorded tape or card into this camera.
- Be sure that the power of the unit is turned off before connecting it to a TV.

### 1 Connect the movie camera and a TV.

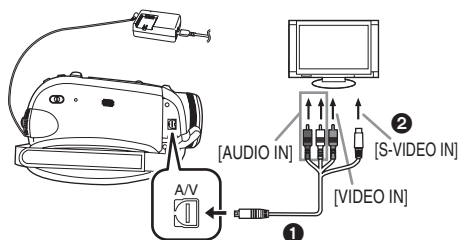

- Connect the movie camera and a TV by using the Multi cable ①.
- If the TV has an S-Video terminal, then also connect to this terminal ②. It allows you to enjoy more beautiful images. (Do not forget to also connect to the Video and Audio terminals.)

### 2 Turn on this camera and set the mode dial to the Tape Playback Mode (or Card Playback Mode).

### 3 Select the input channel on the TV.

- If the images are not played back correctly on the TV (e.g. they are displayed vertically), perform the menu operations in accordance with the aspect ratio of the TV monitor. Set [SETUP] >> [TV ASPECT] >> [16:9] or [4:3].

### 4 Move the joystick up to select the [▶/II] icon to start playback.

- The image and audio are output on the TV.

### 5 Move the joystick down to select the [■] icon to stop playback.

- Whenever plugging in the S-Video terminal, plug in the VIDEO IN terminal and AUDIO IN terminal, too.
- Use the AC adaptor to free you from worrying about the battery running down.

### ■ If the image or audio from this camera is not output on the TV

- Check that the plugs are inserted as far as they go.
- Check the [12bit AUDIO] settings. (-48-)
- Check the connected terminal.
- Check the TV's input setting (input switch). (For more information, please read the operating instructions for the TV.)

### ■ To display the on-screen information on the TV

The information displayed on the LCD monitor or the viewfinder (operation icon, time code and mode indication, etc.) can be displayed on the TV.

(This operation is only available when using the remote control.)

### 1 Press the [EXT DISPLAY] button on the remote control.

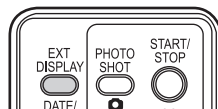

- Press the button again to erase the information.

## Playing back card

### ● Set to Card Playback Mode.

(An operation icon automatically appears on the LCD monitor.)

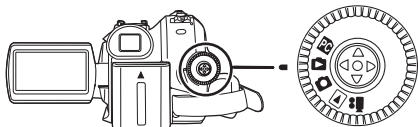

### 1 Operate with joystick.



- ◀: Plays back the previous picture
- ▶: Plays back the next picture
- ▶/■: Slide show (Plays back the still pictures on the card in order) start/pause

- The power will not turn off when the LCD monitor and the viewfinder are closed and retracted during Tape/Card playback mode.
- Even if the operation icon does not appear, the previous or next picture can be displayed.
- While the data on a card are played back, do not operate the mode dial.
- When the access lamp is lit, do not remove a card.
- It takes time to display the file depending on the number of pixels of the file.
- If you attempt to play back file recorded in a different format or file data is defective, the whole display becomes bluish and the "UNPLAYABLE CARD" indication may appear as warning.
- When playing back still pictures recorded in 4:3 mode (3.1m, 2m, 1m, 0.3m) on a wide-screen TV, the picture quality may deteriorate.
- When playing back a file recorded on other equipment, the date and time display is different from when it was recorded.

### ■ To display multiple playback files

Multiple files on the card (6 files on 1 screen) are displayed.

#### 1 Move the [-] /VOL+ lever to switch the images.



Towards [+]: Full-screen display  
(Displays 1 image.)

Towards [-]: Multi-screen display  
(Displays 6 files on 1 screen.)

- In the multi-screen display,
  - Move the joystick to select a file (The selected file will be encircled by a orange frame) and press to determine it. The selected file is full-screen displayed.
  - If there are 7 files or more, then move the joystick. The next, or previous multi-screen will be displayed.

### ■ About the compatibility of still pictures

- The movie camera is compliant with the unified standard DCF (Design rule for Camera File system) established by JEITA (Japan Electronics and Information Technology Industries Association).
- The file format supported by this movie camera is JPEG. (Not all JPEG formatted files will be played back.)
- If an out-of-specs file is played back, the folder/file name may not be displayed.
- The movie camera may degrade or not play back data recorded or created on another product and another product may degrade or not play back data recorded on the movie camera.

## Deleting files recorded on a card

The deleted files cannot be restored.

### ● Set to Card Playback Mode.

- 1 Move the joystick left or right to select a file to delete.



- You can select a file in the multi-screen display. After selecting the file, press the joystick and display the operation icon.

- 2 Move the joystick down to select [  ].



- 3 Move the joystick up or down in order to select [DELETE 1 FILE] and then press it.

- 4 When the confirming message appears, select [YES] and press the joystick.

- In order to stop deletion, select [NO].

### ■ To delete all files

- 1 Move the joystick down to select [  ].



- 2 Move the joystick up or down in order to select [ALL FILES] and then press it.

- 3 When the confirming message appears, select [YES] and press the joystick.

- Do not turn off the power while deleting.
- To delete files, use the AC adaptor or a sufficiently charged battery.
- In case of [ALL FILES], the deletion may take time if there are many files on the card.
- If the "CARD FULL" indication appears when recording, the card is full and no further data can be recorded. Insert a new card or set the camera to Card Playback Mode and delete unnecessary files.
- If files conforming to DCF standard are deleted, all the data related to the files will be deleted.

### ■ Deleting still picture files recorded on a card by other equipment

- A still picture file (other than JPEG) that cannot be played back on the movie camera may be erased.

## Formatting a card

Please be aware that if a card is formatted, then all the data recorded on the card will be erased. Store important data on a personal computer, etc.

### ● Set to Card Playback Mode.

- 1 Set [ADVANCED] >> [FORMAT CARD] >> [YES].
- 2 When the confirmation message appears, select [YES] and press the joystick in order to format the card.

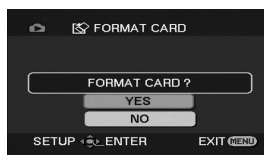

- In order to stop formatting, select [NO].

- Normally, it is not necessary to format the card.

If a message appears even though you insert and remove the card several times, format it.

- If the SD Card is formatted on other equipment, it may take longer to record or you may not be able to use the SD Card. In this case, format the SD Card on this unit.

(Do not format it on a PC etc.)

- Do not remove the card or turn off the power while formatting.
- This unit supports SD Memory Cards formatted in FAT12 system and FAT16 system based on SD Memory Card Specifications and SDHC Memory Cards formatted in FAT32 system.

## Protecting files on a card

Files recorded on a card can be locked so that they may not be deleted by mistake. (Even if the files are locked, they will be deleted if the card is formatted.)

### ● Set to Card Playback Mode.

1 Set [BASIC] >> [PROTECT] >> [YES].

2 Move the joystick to select a file to be locked, and then press it.

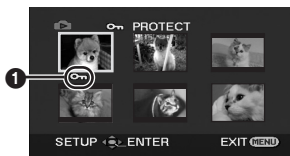

- [OK] Indication ❶ appears and the selected file is locked. Press the joystick again, and the lock will be cancelled.
- 2 or more files can be locked in succession.

### ■ To complete the settings

Press the [MENU] button.

## Writing the printing data on a card (DPOF setting)

You can write the data of pictures to be printed, number of copies, and other information (DPOF data) onto the card.

### ● Set to Card Playback Mode.

1 Set [ADVANCED] >> [DPOF SET] >> [SET].

2 Move the joystick to select a file to be set, and then press it.

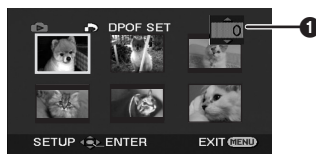

- The number of prints ❶ set to be in DPOF is displayed.
- 3 Move the joystick up or down in order to select the number of prints, and then press it.
- You can select from 0 to 999. (Selected number of pictures can be printed as you set the number of prints with the printer supporting DPOF.)
  - 2 or more files can be set in succession.

### ■ To complete the settings

Press the [MENU] button.

- DPOF setting made on another camera may not be recognised by this camera. Please perform the DPOF settings on your movie camera.

### ■ To set so that all pictures are not printed

Select [CANCEL ALL] in Step 1.

### ■ What is DPOF?

DPOF stands for Digital Print Order Format. This enables the printing information to be added to the pictures on the card so that it can be used on a system supporting DPOF.

## Edit mode

### Recording from a tape onto a card

Still pictures can be recorded on a memory card from scenes that have already been recorded on a cassette.

- Set to Tape Playback Mode.
- Insert a tape which already has recorded contents and a card.

1 Start playback.



2 Pause at the scene you wish to record, and press the [ ] button.

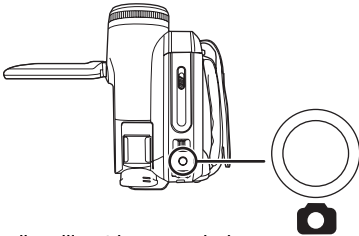

- Audio will not be recorded.

- The size of still pictures recorded on a card becomes [0.2m] (16:9) or [0.3m] (4:3). (This is not mega pixel still-picture recording.)
- If you set [TV ASPECT] >> [4:3], black bands are added to the top and bottom of the picture when wide pictures are recorded to the card. (-34-)
- If you press the [ ] button without pausing, blurred pictures may be recorded.

### Copying onto a DVD recorder or a VCR (Dubbing)

Pictures recorded by the movie camera can be stored on a DVD-RAM or other such media. Refer to the instructions for the recorder.

- Place a recorded cassette in the movie camera, and an unrecorded DVD-RAM or cassette in the DVD recorder or VCR.

1 Connect the movie camera and the recorder.

#### Connecting with the Multi cable

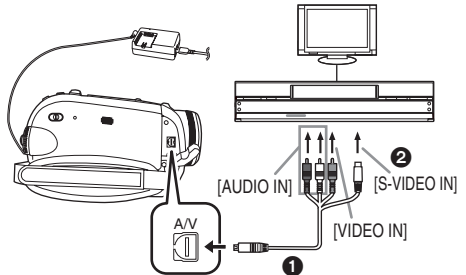

- Connect the movie camera and the recorder by using the Multi cable ①.
- If the recorder has an S-Video terminal, then also connect to this terminal ②. It allows you to copy clearer image.

#### Connecting with the optional DV cable (Only for equipment with a DV terminal)

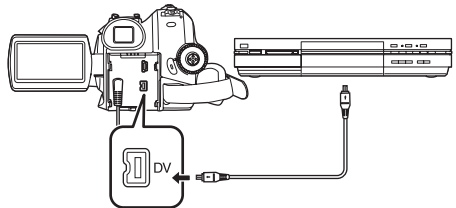

- 2 Turn on the movie camera and set to Tape Playback Mode.
- 3 Select the input channel on the TV set and recorder.
- 4 Move the joystick up to select the [▶/||] icon to start playback. (Player)
  - The image and sound are reproduced.
- 5 Start recording. (Recorder)
- 6 Stop recording. (Recorder)
- 7 Move the joystick down to select the [■] icon to stop playback. (Player)

- If you record (dub) images onto another video device and then play them back on a wide-screen TV, the images may be stretched vertically. In this case, refer to the operating instructions for the device that you are recording (dubbing) to or read the operating instructions for the TV and set to 16:9 (full).
- For more information, refer to the operating instructions for your TV set and recorder.
- When you do not need functional indications or date and time indication, respectively set [SETUP] >> [DISPLAY] >> [OFF] or set [BASIC] >> [DATE/TIME] >> [OFF] in the Tape Playback Mode.  
(When you connect the movie camera and a recorder with the DV cable, these indications may not appear.)

**■ When neither image nor sound from the movie camera is output to the TV set**

- Check that the plugs are inserted as far as they go.
- Check the [12bit AUDIO] settings. (-48-)
- Check the connected terminal.

**Using the DV Cable for Recording (Digital Dubbing)**

By connecting other digital video equipment with DV terminal and the movie camera by using the DV cable VW-CD1E (optional) ①, high-image-quality dubbing can be done in digital format.

**● Set to Tape Playback Mode. (Player/recorder)**

**1 Connect the movie camera and digital video equipment with the DV cable.**

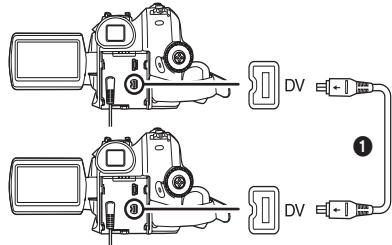

**2 Set [ADVANCED] >> [REC STDBY] >> [YES]. (Recorder)**

- You do not have to follow this step when the remote control is used in the digital dubbing.

**3 Start playback. (Player)**

**4 Start recording. (Recorder)**

**When operating with the main unit:**

Move the joystick up to select [●/||] icon.

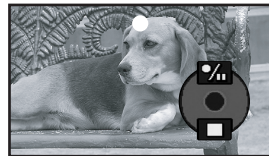

**When operating with the remote control:**

While pressing the [●REC] button on the remote control, press the [PLAY ►] button.

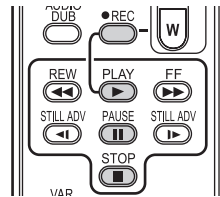

**5 Move the joystick up to select the [●/||] icon again or press the [||] button on the remote control to stop recording. (Recorder)**

**6 Stop playback. (Player)**

## ■ To cancel the standby for recording

When the camera is standby for recording, move the joystick down and select the [■] icon or press the [■] button on the remote control.

- Do not plug or unplug the DV cable during dubbing, or the dubbing may not be completed properly.
- If a picture (bilingual video, etc.) containing main sound and sub sound has been dubbed, select the desired sound by [SETUP] >> [AUDIO OUT] on playback.
- Even if you use a device equipped with DV terminals such as IEEE1394, you may not be able to perform digital dubbing in some cases. For more information, see the instructions for equipment connected.
- Regardless of the menu settings on the recorder, digital dubbing is carried out in the same mode as the [AUDIO REC] mode of the playback tape.
- The images on the recorder monitor may be disturbed, but it does not affect the recorded images.
- If a picture containing a copyright protection signal (copy guard) is recorded by the movie camera, the picture is distorted by mosaic-like patterns at playback.
- Disconnect the USB cable since input signals from the external input terminal cannot be recorded while it is connected with the USB cable.
- While pictures are input from the DV terminal, the operation icon blinks on instead of appearing from the side of the screen when you press the centre of the joy stick.
- While pictures are input from the DV terminal, the TV aspect will not change even if you change the setting for [TV ASPECT] in the [SETUP] menu.

## Audio dubbing

You can add music or narration to the recorded cassette.

**(Audio dubbing can only be performed by using the remote control.)**

### ● Set to Tape Playback Mode.

- 1 Find a scene that you want to add sound to, and press the [II] button on the remote control.

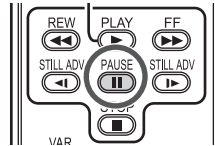

- 2 Press the [AUDIO DUB] button on the remote control to make audio dubbing ready.

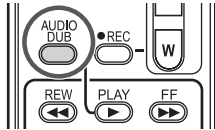

- 3 Press the [II] button on the remote control to start audio dubbing.

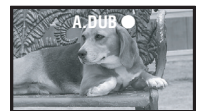
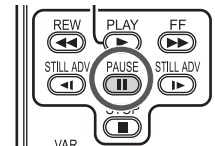

- Be sure that the sound is directed towards the built-in microphone.

- 4 Press the [II] button on the remote control to stop audio dubbing.

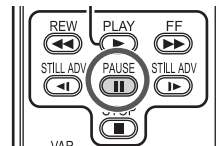

- If a tape has a non-recorded portion when the tape is dubbed, images and sounds may be disturbed when this portion of the tape is played back.

## ■ Before recording with audio dubbing

### ● Set to Tape Recording Mode.

● When you want to preserve the original sound taken during recording, set [ADVANCED] >> [AUDIO REC] >> [12bit] to take pictures. (When set [16bit], the sounds taken during recording are erased after recording with audio dubbing.)

● Set [BASIC] >> [REC SPEED] >> [SP] to take pictures.

## ■ To play back the sound recorded with audio dubbing

You can switch between the sound recorded with audio dubbing and the original sound.

Set [SETUP] >> [12bit AUDIO] >> [ST2] or [MIX].

[ST1]: It only plays back the original sound.

[ST2]: It only plays back the sound added by audio dubbing.

[MIX]: It simultaneously plays back the original sound and the sound added with audio dubbing.

● During audio dubbing, it is automatically set to [ST2].

## Printing pictures by directly connecting to the printer (PictBridge)

To print pictures by directly connecting the movie camera to the printer, use a printer compatible with PictBridge. (Read the operating instructions for the printer.)

### ● Insert a card and set to Card Playback Mode.

#### 1 Connect the movie camera and the printer with the supplied USB cable.

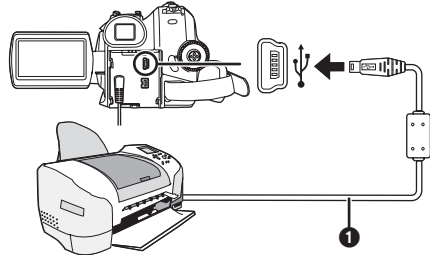

#### 1 USB cable

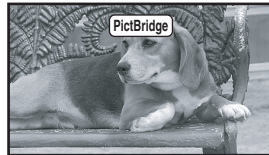

- The [PictBridge] indication appears on the screen of the movie camera. (When the printer is being recognised, the [PictBridge] indication blinks.)
- When no card is inserted in the movie camera, the [PictBridge] indication does not appear. (You cannot print any pictures.)
- When the movie camera and the printer are not connected properly, the [PictBridge] indication keeps blinking. (It will blink for over approx. 1 minute.) Connect the cable or check the printer.
- When images are displayed in multi-screen, they cannot be printed.
- Do not use any other USB connection cables except the supplied one. (Operation is not guaranteed with any other USB connection cables.)

#### 2 Select [SINGLE PRINT] or [DPOF PRINT].

- If there is no file with a DPOF setting, you cannot select [DPOF PRINT].
- When you select [DPOF PRINT] for printing, set the number of prints in DPOF setting.
- When [DPOF PRINT] is selected, print after you determine the paper size. (Step 6)
- When [DPOF PRINT] is selected, date printing is unavailable.



**3 Move the joystick left and right to select a desired picture, and then press it.**



**4 Select the desired number of prints.**

- You can set up to 9 prints.

**5 Select the setting for date printing.**

- If the printer is not capable of date printing, this setting is unavailable.

**6 Select [PAPER SIZE].**

[STANDARD]: Size specific to the printer

[4×5 INCH]

[5×7 INCH]

[4×6 INCH]

[A4]

- You cannot set paper sizes not supported on the printer.

**7 Select [PAGE LAYOUT].**

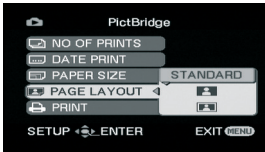

[STANDARD]: Layout set on the printer

[]: No frame

[]: With frame

- You cannot set a layout not supported on the printer.

**8 Set [PRINT] >> [YES] to start printing.**

**■ When you stop printing halfway**

Move the joystick down.

- Avoid the following operations during printing. These operations disable proper printing.
  - Disconnecting the USB cable
  - Removing the card
  - Switching the mode dial
  - Turning off the power
- Check the settings for the paper size, quality of print, etc. on the printer.
- Still pictures recorded on other equipment may not be printed.
- When the movie camera and the printer are connected in the Tape Recording/Playback Mode, the [WEB] Indication may appear on the LCD monitor. However, pictures cannot be printed.
- The sides of pictures recorded when [16:9] is set may be cut at printing. (When you purchase this unit, [REC ASPECT] is set to [16:9].) When using a printer with a trimming or borderless function, cancel this setting. (Refer to the operating instructions of the printer for details.)
- Connect the printer directly to this unit. Do not use a USB hub.

## With a PC

### Before Use

#### Introduction

You can connect your personal computer to a movie camera. You can transfer images recorded with your movie camera to your personal computer.

By controlling the movie camera from the personal computer, the desired images from tape or camera can be acquired into the personal computer.

#### Notes on these instructions

- Microsoft®, Windows®, Windows Vista®, Windows Media®, DirectX®, DirectDraw®, and DirectSound® are either registered trademarks or trademarks of Microsoft Corporation in the United States and/or other countries.
- IBM and PC/AT are registered trademarks of International Business Machines Corporation of the U.S.
- Intel®, Core™, Pentium® and Celeron® are the registered trademarks or trademarks of the Intel Corporation in the United States and other countries.
- Apple, Mac OS, iMovie/iMovie HD/iMovie '08, FireWire are either registered trademarks or trademarks of Apple Inc. in the United States and/or other countries.
- Other names of systems and products mentioned in these instructions are usually the registered trademarks or trademarks of the manufacturers who developed the system or product concerned.
- Microsoft product screen shot(s) reprinted with permission from Microsoft Corporation.
- The names of the products you are using may differ from the names given in the text. Depending on the operating environment and other factors, the contents of the screens used in these instructions may not necessarily match what you will see on your screen.
- Although the screens in these operating instructions are shown in English for the sake of example, other languages are supported as well.
- In this manual, the Panasonic make digital video camera with USB terminal is referred to as movie camera.
- These instructions do not cover the basic operations of the personal computer or define any terms. For this information, refer to the

operating instructions which accompany your personal computer.

#### Names and functions of packaged items

##### 1) USB cable:

- This cable is used to connect a personal computer with your movie camera.

##### 2) CD-ROM:

SweetMovieLife 1.1E (-54-)  
 MotionDV STUDIO 6.0E LE (-54-)  
 USB Driver (-52-)  
 DirectX

- If the movie camera is connected to your personal computer, you can send video from the movie camera to the other parties via the network. (Windows Vista, Windows XP SP1/SP2, Windows 2000 SP4)
- To activate SweetMovieLife/MotionDV STUDIO, Microsoft DirectX 9.0b/9.0c should be installed. If it is not installed in your personal computer, you can install it from the supplied CD-ROM. Click [DirectX] on the CD launcher and then follow the instruction message on the screen to install it. (During installation of USB Driver, SweetMovieLife or MotionDV STUDIO, you can also install DirectX 9.0b.)
- Using the SweetMovieLife software allows you to easily import video on a tape to a personal computer and then auto edit the imported video. For advanced importing and editing, use MotionDV STUDIO.
- Using the MotionDV STUDIO software allows you to capture the video recorded on a tape or images viewed through the lens of a camera.
- You can only output the video from the personal computer to the movie camera when connecting the movie camera to the personal computer with the DV cable.

## ■ Check before Use

The software available and the drivers required vary depending on the OS of the personal computer. Check the software used and the drivers required using the table below and then install them from the CD-ROM.

Purpose of use	Software used	Installation of drivers			
		Windows			Mac OS
		Vista	XP	2000	
1)	①	●	●	●	●
2)	②	● *9	● *1, 3	● *1, 5	● *8
	③	● *2, 9	● *1, 2, 3	USB Driver *1, 2, 5	—
3)	②	● *9	● *1, 3	● *1, 5	● *8
	③	—	—	—	—
4)	④	●	USB Driver *1, 4, 6	USB Driver *5, 7	—

●: not required    —: not available

- 1) **Copying files in the card onto the personal computer**
    - PC connection mode
  - 2) **Capturing pictures on the tape to the personal computer**
    - Tape recording mode
    - Tape playback mode
  - 3) **Recording pictures on the personal computer to the tape**
    - Tape playback mode
  - 4) **Using the movie camera as a WEB camera**
    - Tape recording mode
    - Tape playback mode
- ① **No software**  
(The movie camera is used as a removable disc.)
- ② **SweetMovieLife/MotionDV STUDIO**  
(Connect with the DV cable (optional).)  
**iMovie 4/iMovie HD/iMovie '08** (Connect with the FireWire (DV) cable (not supplied).)
- ③ **SweetMovieLife/MotionDV STUDIO**  
(Connect with the USB cable (supplied).)
- ④ **MSN Messenger/Windows Live Messenger**

\*1 If DirectX 9.0b/9.0c is not installed in the personal computer you use, the installation of [DirectX] is required.

\*2 The personal computer you use should comply with USB port (Hi-Speed USB(USB 2.0)).

\*3 Available only on Windows XP SP2

\*4 Available only on Windows XP SP1/SP2

\*5 Available only on Windows 2000 SP4

\*6 Not required for Windows XP SP2

\*7 Available only on MSN Messenger

\*8 Available only on Mac OS X v10.4

\*9 Available only on Windows Vista Home Basic/ Home Premium

●If using other brands of video editing software, please consult with your retailer for compatibility.

## ■ Operating environment

- Even if the system requirements mentioned in these operating instructions are fulfilled, some personal computers cannot be used.
- A CD-ROM drive is required to install this programme.
- This software is not compatible with Microsoft Windows 3.1, Windows 95, Windows 98/98SE, Windows Me and Windows NT.
- Operation on an upgraded OS is not guaranteed.
- Operation on an OS other than the one pre-installed is not guaranteed.

### *SweetMovieLife 1.1E/*

### *MotionDV STUDIO 6.0E LE for DV*

#### OS:

IBM PC/AT compatible personal computer with pre-installed;

Microsoft Windows Vista Home Basic/ Home Premium

Microsoft Windows XP Home Edition/ Professional SP2

Microsoft Windows 2000 Professional SP4

#### CPU:

Intel Pentium III 800 MHz or higher (including compatible CPU)

(Intel Pentium 4 1.6 GHz or higher recommended)

#### Graphic display:

High Colour (16 bit) or more

(32 bit recommended)

Desktop resolution of 1024×768 pixels or more (1280×1024 pixels or more recommended)

Graphics card complying with DirectX 9.0b or DirectX 9.0c, and DirectDraw overlay

#### Sound:

DirectSound Support

#### RAM:

Windows Vista: 512 MB or more (1 GB or more recommended)

Windows XP/2000: 256 MB or more (512 MB or more recommended)

**Free hard disk space:**

Ultra DMA – 33 or more (100 or more is recommended)

640 MB or more

Separate free space is required for importing and editing video.

[1 GB capacity is required for a video of around 4 minutes in the AVI (DV-AVI) format.]

**Interface:**

DV (IEEE1394) terminal (IEEE1394.a)

USB port (Hi-Speed USB(USB 2.0)) (only compatible with importing video)

**Other requirements:**

Mouse or equivalent pointing device

**Software:**

Windows Vista: DirectX 10

Windows XP/2000: DirectX 9.0b/9.0c

- If this software is installed on a personal computer that does not support DirectX versions above, the personal computer may not operate properly. If you are unsure if your personal computer is compatible, contact the maker.

Windows Media Player 6.4 to 11

- Supplied CD-ROM is available for Windows only.
- This software is not compatible with a multi-CPU environment.
- This software is not compatible with a multi-boot environment.
- Operation is not guaranteed on Microsoft Windows XP Media Center Edition, Tablet PC Edition and not compatible with 64 bit operation systems.
- If using Windows XP/2000, an administrative account user only can use this software. If using Windows Vista, administrative account and standard account users only can use this software. (An administrative account user should install and uninstall this software.)
- When 2 or more USB devices are connected to a personal computer, or when devices are connected through USB hubs or by using extension cables, proper operation is not guaranteed.
- When connected to the keyboard USB terminal, normal function may not be possible.
- This instruction manual describes only the procedures for installation, connection and start-up. Please read the PDF-based instructions for how to use the SweetMovieLife/MotionDV STUDIO.
- To view the installed operating instructions, Adobe Acrobat Reader 5.0 or later or Adobe Acrobat Reader 7.0 or later are required.

- Before using for the first time, select [Readme First] from [start] >> [All Programs (Programs)] >> [Panasonic] >> [SweetMovieLife 1.1E]/[MotionDV STUDIO 6.0E LE for DV], and read any supplementary details or updates.

**USB Driver****OS:**

IBM PC/AT compatible personal computer with pre-installed;

Microsoft Windows Vista Home Basic/Home Premium/Ultimate/Business/Enterprise \*1

Microsoft Windows XP Home Edition/Professional SP1/SP2 \*1

Microsoft Windows 2000 Professional SP4

**CPU:**

Windows Vista: Intel Pentium III 1.0 GHz or higher

Windows XP/2000: Intel Pentium III 450 MHz or higher

**Graphic display:**

High Colour (16 bit) or more

Desktop resolution of 800×600 pixels or more

**RAM:**

Windows Vista Home Basic: 512 MB or more

Windows Vista Home Premium/Ultimate/Business/Enterprise: 1 GB or more

Windows XP/2000: 128 MB or more (256 MB or more recommended)

**Free hard disk space:**

250 MB or more

**Communication Speed:**

56 kbps or faster is recommended

**Interface:**

USB port

**Other requirements (to send/receive audio):**

Sound card

Speaker or headphones

Mouse or equivalent pointing device

**Software:**

MSN Messenger 7.0 (Windows 2000)

Windows Live Messenger 8.1 (Windows Vista/XP)

DirectX 9.0b/9.0c

\*1 When your OS is Windows Vista/XP SP2, the USB driver is not needed.

- This software is not compatible with a multi-CPU environment.
- This software is not compatible with a multi-boot environment.
- Operation is not guaranteed on Microsoft Windows XP Media Center Edition, Tablet PC Edition and not compatible with 64 bit operation systems.

To use the movie camera as a Web Camera, the following conditions must be met.

- To upgrade Windows XP to SP2, click [start] >> [All Programs] >> [Windows Update]. (Requires internet connection.)
- To upgrade Windows 2000 to SP4, click [start] >> [Windows Update]. (Requires internet connection.)
- If the installed version is not latest, update it by performing the Windows update.
- Depending on the security setting on PC, proper communication will not be possible.
- The other parties also need to use same Messenger software during the communication.

### Card reader function

#### OS:

IBM PC/AT compatible personal computer with pre-installed;

Microsoft Windows Vista

Microsoft Windows XP

Microsoft Windows 2000

#### CPU:

Windows Vista: Intel Pentium III 1.0 GHz or higher

Windows XP/2000: Intel Pentium III 450 MHz or higher

#### RAM:

Windows Vista Home Basic: 512 MB or more

Windows Vista Home Premium/Ultimate/  
Business/Enterprise: 1 GB or more

Windows XP/2000: 128 MB or more (256 MB or more recommended)

#### Interface:

USB port

#### Other requirements:

Mouse or equivalent pointing device

## Install/Connection

### ■ Installing USB Driver

Install this when your OS is Windows XP SP1, or Windows 2000 SP4.

(When your OS is Windows Vista/Windows XP SP2, installing USB Driver is not needed.)

USB Driver is needed to be installed when you connect the movie camera to the PC with the supplied USB cable and use SweetMovieLife/ MotionDV STUDIO or Web Camera.

DirectX 9.0b is installed in your PC if it is not installed beforehand. Applications which are compatible with older version of DirectX may not operate properly by installing DirectX 9.0b. In this case, consult the manufacturers of the applications disabled.

#### 1 Insert the supplied CD-ROM into the personal computer's CD-ROM drive.

- Quit all applications.
- The [Setup Menu] screen appears.

#### 2 Click [USB Driver].



- The set up programme starts running.

#### 3 You may be required to install DirectX 9.0b depending on the environment of the personal computer. In this case, click [Yes] to install it.



- Reboot the computer after DirectX is installed.

- Do not take out the CD-ROM.

#### 4 Finish installation by following the on-screen instructions.

- Click [Next] and proceed with installation.
- After completing the installation, click [Finish].
- Reboot the computer to finish installing USB Driver.

**Depending on your personal computer, one of the following screens may appear.**

- 1 Your personal computer does not support USB port (Hi-Speed USB(USB 2.0)) so the video on tape cannot be imported from the video camera to the personal computer with the USB cable.



- You can use the Web Camera function.

- 2 The personal computer has recognised a Hi-Speed USB(USB 2.0) driver other than the Microsoft driver. Update the driver to make sure that it operates properly. (-55-)



- 3 The Hi-Speed USB(USB 2.0) driver may not be recognised correctly. Update the driver to make sure that it operates properly. (-55-)

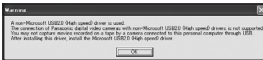

## ■ Installing SweetMovieLife 1.1E

SweetMovieLife 1.1E is aimed at entry-level users. Using this software, you can easily import video recorded with a digital video camera to a personal computer, create a title and add music to the video and then perform auto edit on it. For advanced importing and editing, use MotionDV STUDIO.

DirectX 9.0b is installed in your PC if it is not installed beforehand. Applications which are compatible with older version of DirectX may not operate properly by installing DirectX 9.0b. In this case, consult the manufacturers of the applications disabled.

- When you use Windows 2000 (SP4) to connect the personal computer and the movie camera by USB cable and then use SweetMovieLife, installing the USB driver is needed.

### 1 Insert the supplied CD-ROM into the personal computer's CD-ROM drive.

- Quit all applications.
- The [Setup Menu] screen appears.

### 2 Click [SweetMovieLife 1.1E].



- After reading the displayed contents, please carry out the installation according to instructions.

### 3 Select the video system.

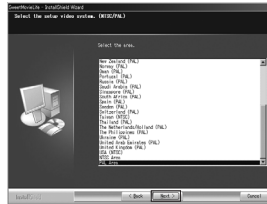

### 4 After the completion of setup, click on [Finish].

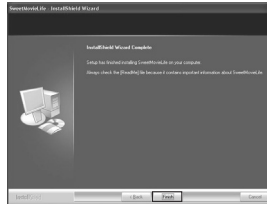

- Sample data is installed concurrently with the SweetMovieLife.
- After installation, if you click [SweetMovieLife 1.1E] in the Setup Menu, the uninstallation starts. Click [EXIT] in the Setup Menu to close the Setup Menu.

## ■ Installing MotionDV STUDIO 6.0E LE

MotionDV STUDIO allows more advanced editing than SweetMovieLife. Using this software allows you to capture video recorded on a tape or images viewed through the lens of a camera. Connecting the movie camera with the DV cable allows you to output images edited on a personal computer to a tape in a movie camera. You can also add a wide variety of special effects such as fade, transition and titles.

DirectX 9.0b is installed in your PC if it is not installed beforehand. Applications which are compatible with older version of DirectX may not operate properly by installing DirectX 9.0b. In this case, consult the manufacturers of the applications disabled.

- When you use Windows 2000 (SP4) to connect the personal computer and the movie camera by USB cable and then use MotionDV STUDIO, installing the USB driver is needed.

**1 Insert the supplied CD-ROM into the personal computer's CD-ROM drive.**

- Quit all applications.
- The [Setup Menu] screen appears.

**2 Click [MotionDV STUDIO 6.0E LE].**



- After reading the displayed contents, please carry out the installation according to instructions.

**3 Select the video system.**

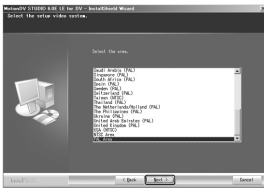

**4 After the completion of setup, click on [Finish].**



- Sample data is installed concurrently with the MotionDV STUDIO.
- After installation, if you click [MotionDV STUDIO 6.0E LE] in the Setup Menu, the uninstallation starts. Click [EXIT] in the Setup Menu to close the Setup Menu.

**■ Connecting the movie camera to personal computer**

**Confirmation before connection**

When you connect the personal computer and the movie camera with the USB cable and then use SweetMovieLife/MotionDV STUDIO on Windows

Vista, Windows XP (SP2) or Windows 2000 (SP4), check the driver of the USB host controller.

- It is required to use the driver for which [Microsoft] is displayed on [Driver Provider] in [Driver] tab.

(for Windows XP/2000)

- 1 Select [start] >> [Settings] >> [Control Panel] to start [System].
  - [System Properties] is displayed.
- 2 Click [Hardware] tab and then click [Device Manager].
- 3 Right-click [Enhanced Host Controller] etc. in [Device Manager] and then select [Properties].



- The indication [Enhanced Host Controller] is changed as [EHCI] depending on the host controller you use.

**4 Click [Driver] tab to check the description on [Driver Provider].**



- If [Microsoft] is displayed on [Driver Provider], the confirmation procedure is completed.

(for Windows Vista)

- 1 Select [start] >> [Control Panel] >> [System and Maintenance] to start [Device Manager].
- 2 Right-click [Enhanced Host Controller] etc. in [Device Manager] and then select [Properties].



- The indication [Enhanced Host Controller] is changed as [EHCI] depending on the host controller you use.

**3 Click [Driver] tab to check the description on [Driver Provider].**



- If [Microsoft] is displayed on [Driver Provider], the confirmation procedure is completed.

**If a description other than [Microsoft] is displayed**

- Update the driver with the following procedure. (for Windows XP/2000)

**1 Click [Update Driver...].**



**2 Check [Install from a list or specific location (Advanced)] and then click [Next].**



- When your OS is Windows 2000, click [Next] after [Update Device Driver Wizard] appears.

**3 (When your OS is Windows XP) Check [Don't search. I will choose the driver to install] and then click [Next].**

**(When your OS is Windows 2000) Check [Display a list of the known drivers for this device so that I can choose a specific driver] and then click [Next].**

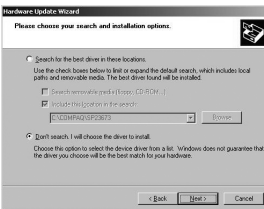

**4 Click [Standard Universal PCI to USB Host Controller] and then click [Next].**

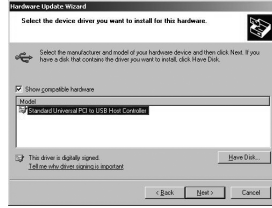

**5 Click [Finish].**

- The update of the driver is completed. Connect the movie camera.

**(for Windows Vista)**

**1 Click [Update Driver...].**

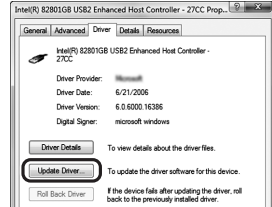

**2 Click [Browse my computer for driver software].**

**3 Click [Let me pick from a list of device drivers on my computer]**

**4 Click [Standard Enhanced PCI to USB Host Controller] and then click [Next].**



**5 Click [Close].**

- The update of the driver is completed. Connect the movie camera.



## Software

### ■ Using SweetMovieLife 1.1E/MotionDV STUDIO 6.0E LE (Windows Vista, Windows XP SP2, Windows 2000 SP4)

If you wish to capture data from a tape, set the movie camera to tape playback mode and insert the tape. If you wish to capture images from the lens of the movie camera, set the movie camera to the tape recording mode and remove the tape and the card.

- If a short-cut icon has been created on the desktop during installation, it is also possible to start by double-clicking on the icon.
- Please read the PDF-based instructions for how to use it.
- The screen is the MotionDV STUDIO selection screen.

#### About the PDF operating instructions for SweetMovieLife/MotionDV STUDIO

For details on how to use the software applications, read the help file.

- 1 Set [start] >> [All Programs (Programs)] >> [Panasonic] >> [SweetMovieLife 1.1E] or [MotionDV STUDIO 6.0E LE for DV] >> [Manual(PDF format)].



- Start the software and select [Help] >> [Help] from the menu to display the help file.
- You will need Adobe Acrobat Reader 5.0 or later or Adobe Reader 7.0 or later to read the PDF operating instructions.

### With USB cable (supplied)

The personal computer should be compatible with USB port (Hi-Speed USB(USB 2.0)).

- 1 Set the movie camera to tape playback mode or tape recording mode.
  - You cannot use SweetMovieLife in tape recording mode.
- 2 Set [BASIC] or [ADVANCED] >> [USB FUNCTION] >> [MOTION DV].
- 3 Connect the movie camera to personal computer with auxiliary USB cable.

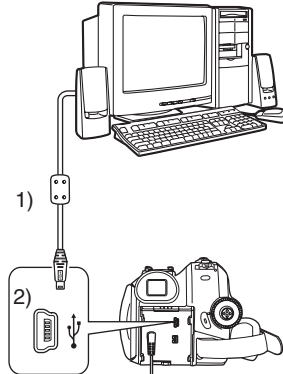

- 1) USB cable
- 2) USB terminal

- Do not use any other USB connection cables except the supplied one. (Operation is not guaranteed with any other USB connection cables.)

- 4 Select [start] >> [All Programs (Programs)] >> [Panasonic] >> [SweetMovieLife 1.1E]/[MotionDV STUDIO 6.0E LE for DV] >> [SweetMovieLife]/[MotionDV STUDIO LE for DV].



- You cannot record the video edited by the PC onto the tape in the movie camera.

**With DV cable (optional)**

**1 Set the movie camera to tape recording mode or tape playback mode.**

- You cannot use SweetMovieLife in tape recording mode.

**2 Connect the movie camera to personal computer with auxiliary DV cable.**

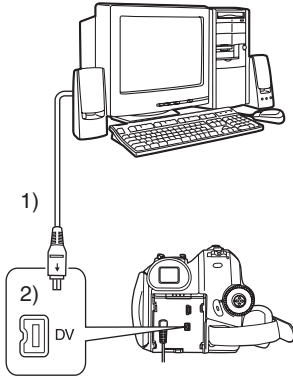

- 1) DV cable
- 2) DV terminal

**3 Select [start] >> [All Programs (Programs)] >> [Panasonic] >> [SweetMovieLife 1.1E]/[MotionDV STUDIO 6.0E LE for DV] >> [SweetMovieLife]/[MotionDV STUDIO LE for DV].**



- You can record the video edited by the PC onto the tape in the movie camera.

**Using the movie camera as a Web Camera (Windows Vista, Windows XP SP1/SP2, Windows 2000 SP4)**

To upgrade Windows XP to SP2, click [start] >> [All Programs (Programs)] >> [Windows Update]. If the movie camera is connected to your personal computer, you can send video and sound from the movie camera to the other parties via the network. Audio may also be exchanged if the personal computer is configured accordingly. (You can use the microphone equipped with the personal computer instead of the one on the movie camera.)

- Refer to page -53- for the minimum requirements.

**Connecting the movie camera to personal computer (For using as a Web Camera)**

- 1 Install USB Driver. (-53-)
- 2 Set the movie camera to tape playback mode or tape recording mode.
- 3 Set [BASIC] or [ADVANCED] >> [USB FUNCTION] >> [WEBCAM].
- 4 Connect the movie camera to personal computer with auxiliary USB cable .

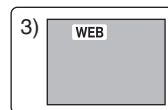
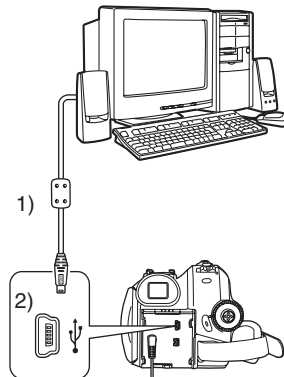

- 1) USB cable
- 2) USB terminal
- 3) The Web Camera mode screen

- Do not use any other USB connection cables except the supplied one. (Operation is not

guaranteed with any other USB connection cables.)

## 5 Start the MSN Messenger/Windows Live Messenger.

- Click [start] >> [All Programs (Programs)] >> [MSN Messenger]/[Windows Live Messenger].
- To send pictures recorded on a tape to other personal computer using the MSN Messenger/Windows Live Messenger, set [BASIC] >> [USB FUNCTION] >> [WEBCAM] on tape playback mode before connecting the movie camera to your personal computer.

## When you use the movie camera as a Web Camera

When you use the movie camera as a Web Camera in the tape playback mode, the indication of the operation icon is different from the one in usual operation.

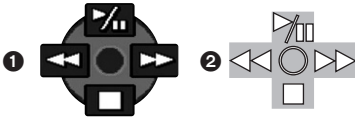

- 1 In usual operation
  - 2 In the Web Camera mode (Tape playback mode)
- Even if you move the joystick up/down/right/left (▶/⏏, ◼, ▶▶, ◀◀), the selected direction on the operation icon is not lit in yellow.
  - The operation icon blinks on instead of appearing from the side of the screen when you press the centre of the joystick.

## Others

### ■ Copying files to a personal computer - Card reader function (Mass storage)

If you connect the movie camera to a personal computer with the USB cable, you can use the movie camera which includes a card as a external drive of a personal computer and you can copy files recorded on the card to the personal computer with [Explorer] etc.

### Copying files recorded on a card to a personal computer

- 1 Select the PC connection mode on the movie camera and then connect the movie camera with the personal computer.

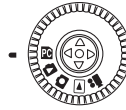

- If the movie camera is connected in the PC connection mode, the [Removable Disk] icon representing the memory card drive is displayed in [My Computer (Computer)].
- 2 Double-click the folder where the desired file is saved in [Removable Disk].

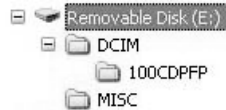

- Still pictures (JPEG format) are saved in [100CDPFP] folder.
- 3 Drag and drop the file onto the destination folder (hard disk of the personal computer).



**Note on the folder structure of the card**

A card formatted with the movie camera is composed by folders as described in the illustration below.

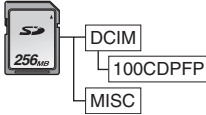

- [100CDPFP]: The images (IMGA0001.jpg, etc.) in this folder are recorded in the JPEG format.
- [MISC]: Files in which DPOF data has been set to the image are in this.

- The other folders in the card are necessary items in the folder structure. They have nothing to do with actual operations.

**Viewing files copied from a card**

- 1 Open the folder to which still picture files are copied.
  - 2 Double-click a file you want to view.
- The software activated to view still picture files varies depending on the settings of the personal computer you use.

**To disconnect USB cable safely**

If USB cable is disconnected while computer is on, error dialogue may appear. In such case click [OK] and close the dialogue box. By following the steps below you can disconnect the cable safely.

- 1 Double click the icon in task tray.



- Hardware disconnect dialogue appears.
- 2 Select [USB Mass Storage Device] and click [Stop].



**3 Verify [Matshita DVC USB Device] is selected and click [OK].**



- Click [Close], and you can safely disconnect the cable.

**Note on the driver name displayed**

The driver name displayed will differ depending on your OS, operating environment and the mode of the movie camera. The name is displayed as [USB Mass Storage Device] or [Matshita DVC USB Device] in PC connection mode.

- Make sure movie camera's function light is off and disconnect the cable.

**If you no longer need software or driver (Uninstall)**

The screens may vary with the type of the OS. (In this manual, explanation is offered with Windows XP screen.)

- 1 Select [start] (>> [Settings]) >> [Control Panel], select the software or the driver from [Add or Remove Programs (Applications)] or [Uninstall a program] to uninstall.



- Uninstalling steps may vary depending on the OS. Please refer to the user manual of your OS.

## ■ Using on Macintosh

- Even if the system requirements mentioned in these operating instructions are fulfilled, some personal computers cannot be used.
- PowerPC is a trademark of International Business Machines Corporation.

### *Operating environment on iMovie 4/ iMovie HD/iMovie '08*

#### OS:

With pre-installed;  
Mac OS X v10.4

#### CPU:

PowerPC G5 (1.8 GHz or higher)

Intel Core Duo

Intel Core Solo

#### RAM:

64 MB or more

#### Interface:

DV (FireWire) terminal (IEEE1394.a)

- Supplied CD-ROM is available for Windows only.
- iMovie/iMovie HD/iMovie '08, included with any new Macintosh or sold with iLife.

#### **1 Set the movie camera to Tape Playback Mode.**

#### **2 Connect the movie camera to your Macintosh with the DV Interface Cable (optional).**

- For more information, please contact Apple Inc. at <http://www.apple.com>.

### *Copying still pictures on PC*

#### OS:

With pre-installed;  
Mac OS X v10.4

#### **1 Connect the movie camera to the personal computer via the supplied USB cable.**

#### **2 Double-click [NO\_NAME] or [Untitled] displayed on the desktop.**



- Files are stored in [100CDPFP] folder in the [DCIM] folder.

#### **3 Using a drag-and-drop operation, move the pictures you want to acquire or the folder storing those pictures to any different folder on the personal computer.**

### *To disconnect USB cable safely*

Drag [NO\_NAME] or [Untitled] disk icon to the [Trash], and then disconnect the USB cable.

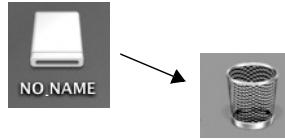

## ■ Notes

- Do not disconnect USB cable while the status indicator of the movie camera is on. It may freeze the software or destroy the data in transfer.
- When the movie camera is switched to the PC connection mode while it is connected to the personal computer, the operation mode of the movie camera cannot be switched. In this case, disconnect the USB cable. Switch the operation mode of the movie camera and reconnect the cable.
- If the movie camera is used as a Web Camera, the quality of the video to be exchanged will depend on the Internet connection status.
- In the Web Camera mode, video (picture) cannot be recorded onto a tape or a card.
- In the Web Camera mode, the audio may be interrupted in the midway of communication depending on the communication environment or the performance of the personal computer.
- If you connect the USB cable while you operate a tape in the tape playback mode, the tape will be stopped.
- If you connect the USB cable in the Web Camera mode (tape recording mode), the time code indication, the SP/LP indication, or icons disappear.
- In the Web Camera mode (tape playback mode), the operation icon is changed.
- If the movie camera is used as a Web Camera while virus checking software is running, the movie camera's operation may stop midway through. In this case, exit the Messenger, reconnect the movie camera and restart the Messenger.
- We recommend using AC adaptor as the power source for the movie camera when connecting to the personal computer. Data may be lost if the battery power is lost while transferring.
- Do not delete the folders in a card. The card may not be recognised if deleted.
- If you install the USB Driver while the USB cable is being connected, or if you don't follow these operating instructions, the movie camera will not be recognised correctly. In this case, delete the driver from [Device Manager] as described below, uninstall the driver, and re-install it. Set the movie camera to tape recording mode, tape playback mode or PC connection mode, connect it to the personal computer, and delete [DVC] or [Web-Camera] from [Device Manager].

## Menu

### Menu list

Menu figures and illustrations are provided for easy-to-understand explanations, and so they are different from the actual menu indications.

#### ■ [TAPE RECORDING MENU]

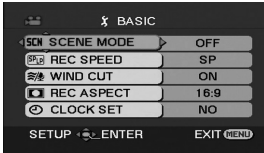

- 1) [BASIC]
  - [SCENE MODE] -35-
  - [REC SPEED] -24-
  - [WIND CUT] -33-
  - [REC ASPECT] -34-
  - [CLOCK SET] -12-
- 2) [ADVANCED]
  - [PICT.QUALITY] -28-
  - [PICTURE SIZE] -28-
  - [O.I.S.] -35-
  - [GUIDE LINES] -35-
  - [FADE COLOUR] -33-
  - [AUDIO REC] -65-
  - [USB FUNCTION] -57-
  - [D.ZOOM] -29-
  - [ZOOM MIC] -29-
- 3) [SETUP]
  - [DISPLAY] -65-
  - [DATE/TIME] -65-
  - [POWER SAVE] -65-
  - [QUICK START] -14-
  - [AGS] -33-
  - [REMOTE] -23-
  - [BEEP SOUND] -65-
  - [POWER LCD] -21-
  - [LCD SET] -21-
  - [EVF SET] -21-
  - [INITIAL SET] -65-
  - [DEMO MODE] -65-
- 4) [LANGUAGE] -19-

#### ■ [TAPE PLAYBACK MENU]

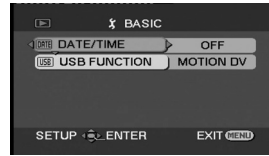

- 1) [BASIC]
  - [DATE/TIME] -65-
  - [USB FUNCTION] -57-
- 2) [ADVANCED]
  - [REC SPEED] -24-
  - [REC STDBY] -46-
  - [REC DATA] -65-
  - [PICT.QUALITY] -28-
  - [REPEAT PLAY] -39-
- 3) [SETUP]
  - [12bit AUDIO] -48-
  - [AUDIO OUT] -65-
  - [DISPLAY] -65-
  - [REMOTE] -23-
  - [POWER LCD] -21-
  - [LCD SET] -21-
  - [EVF SET] -21-
  - [POWER SAVE] -65-
  - [TV ASPECT] -41-
- 4) [LANGUAGE] -19-

## ■ [CARD RECORDING MENU]

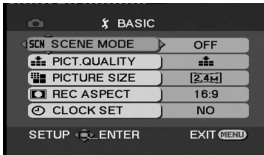

- 1) [BASIC]
  - [SCENE MODE] -35-
  - [PICT. QUALITY] -28-
  - [PICTURE SIZE] -28-
  - [REC ASPECT] -34-
  - [CLOCK SET] -12-
- 2) [ADVANCED]
  - [O.I.S.] -35-
  - [GUIDE LINES] -35-
  - [SHTR EFFECT] -28-
- 3) [SETUP]
  - [DISPLAY] -65-
  - [DATE/TIME] -65-
  - [POWER SAVE] -65-
  - [QUICK START] -14-
  - [REMOTE] -23-
  - [BEEP SOUND] -65-
  - [POWER LCD] -21-
  - [LCD SET] -21-
  - [EVF SET] -21-
  - [INITIAL SET] -65-
- 4) [LANGUAGE] -19-

## ■ [CARD PLAYBACK MENU]

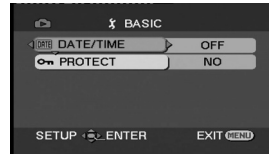

- 1) [BASIC]
  - [DATE/TIME] -65-
  - [PROTECT] -44-
- 2) [ADVANCED]
  - [DPOF SET] -44-
  - [FORMAT CARD] -43-
- 3) [SETUP]
  - [DISPLAY] -65-
  - [REMOTE] -23-
  - [POWER LCD] -21-
  - [LCD SET] -21-
  - [EVF SET] -21-
  - [POWER SAVE] -65-
  - [TV ASPECT] -41-
- 4) [LANGUAGE] -19-



## Menus related to taking pictures

### ■ [DATE/TIME]

This switches between date and time indications.

- The movie camera automatically records the date and time of picture taking on the tape/card.
- You can also show or change the date/time indication by repeatedly pressing the [DATE/TIME] button on the remote control.

### ■ [AUDIO REC]

Switches the audio (PCM audio) recording systems.

- [12bit]: Records audio in "12 bit 32 kHz 4 tracks".  
(The original audio signals can be kept after the other audio signals are dubbed.)
- [16bit]: Records audio in "16 bit 48 kHz 2 tracks".  
Audio can be recorded in higher quality.  
(If audio signals are dubbed, then the original audio signals will be erased.)

### ■ [DISPLAY]

Set to [ON] and the display mode can be switched to all functions. Set to [OFF] and it can be switched to minimum display.

### ■ [BEEP SOUND]

Set to [ON] and confirmation/alarm beeps are issued as follows.

1 Beep

- When you start recording
- When you turn on the power
- When the unit goes from quick start standby mode to recording pause

2 Beeps

- When you pause recording
- When you turn off the power
- When the unit goes into quick start standby mode

2 Beeps for 4 times

- When a cassette with its erasure prevention tab set to [SAVE] is inserted, condensation occurs (-72-), and at other times. Check the sentence displayed on the screen. (-67-)

### ■ [POWER SAVE]

[OFF]: When about 5 minutes passed without any operation, the standby mode automatically will be set. In the standby mode, [■■] blinks and it takes time more than usual to start recording after you press the recording start/stop button.

[5 MINUTES]: When about 5 minutes passed without any operation, the movie camera automatically turns off to protect the tape or to prevent the battery from running down. When

you use the movie camera, turn it on again.

- In the following cases, the power may not turn off even when set [POWER SAVE] >> [5 MINUTES].
  - When connecting to the AC outlet (When using the AC adaptor)
  - When connecting the USB cable or the DV cable to a personal computer or other equipment
  - When in PC Connection Mode

## Menus related to playback

### ■ [REC DATA]

Set to [ON] and the settings (shutter speed, iris/gain values, and white balance settings (-36-), etc.) used during the recordings are displayed during playback.

- If the [AUTO/MANUAL/FOCUS] switch was set to [AUTO] when recording, [AUTO] appears on the display.
- When there is no data, [---] appears on the display.
- If data recorded on this unit is played back on other equipment (or a tape recorded on other equipment is played back on this unit), the settings information is sometimes not displayed normally.

### ■ [AUDIO OUT]

This switches the sound to be played back.

[STEREO]: Stereo sound (main sound and sub sound)

[L]: Left channel sound (main sound)

[R]: Right channel sound (sub sound)

## Other menus

### ■ [INITIAL SET]

When there is a menu that cannot be selected depending on a combination of functions, set to [YES] for changing the menu settings back to the initial shipping condition.

(Language setting cannot be back to the initial shipping condition.)

### ■ [DEMO MODE]

If you set to [DEMO MODE] >> [ON] without inserting a cassette and a card, the movie camera is automatically set to the demonstration mode for introducing its functions. If any button is pressed or operated, the demonstration mode is cancelled. If no operations take place for approx. 10 minutes, the demonstration mode automatically starts. To terminate the demonstration mode, insert a cassette or a card, or set to [DEMO MODE] >> [OFF]. For normal use, set this function to [OFF].

## Others























### Indications



Various functions and the movie camera status are shown on the screen.

#### Basic indications



- : Remaining battery power
- 0h00m00s00f: Time code
- 15:30:45: Date/Time indication

#### Recording indications



















- R 0:45: Remaining tape time
- Remaining tape time is indicated in minutes. (When it reaches less than 3 minutes, the indication starts flashing.)
- SP: Standard Play mode (Recording speed mode) -24-
- LP: Long Play mode (Recording speed mode) -24-
- Recording -25-
- || (Green): Recording pause -25-
- || (Green flash): Standby mode
- || (Red): Fade out
- : POWER LCD -21-
- : Recording check -26-
-  16:9: Wide mode -34-
-  AUTO: Automatic mode -24-
-  MNL: Manual mode -35-
- MF: Manual focus -37-
- 5X: Zoom magnification indication -29-
- : Backlight mode -30-
- : OIS -35-
- 1/500: Shutter speed -38-
- F2.4: F number -38-
- 6dB: Gain value -38-
-  WEB: WEB CAMERA mode (Recording) -49-
- : Soft skin mode -31-
- : Tele macro -32-
-  W: Fade (White) -32-
-  B: Fade (Black) -32-
- : Blank search -26-
- : Colour night view function -31-
-  ZOOM : Zoom microphone -29-
- : Wind noise reduction -33-
- : Sports mode (Scene mode) -35-
- : Portrait mode (Scene mode) -35-
- : Low light mode (Scene mode) -35-
- : Spotlight mode (Scene mode) -35-
- : Surf & snow mode (Scene mode) -35-
-  AWB: Auto white balance -36-

- : Indoor mode (recording under incandescent lamp) -36-
- : Outdoor mode -36-
- : White balance adjustment mode -36-

#### Playback indications

- Recording underway
- ▶ Playback -39-
- || Pause -39-
- ▶▶ Fast-forward/Cue playback -39-
- ◀◀ Rewind/Review playback -39-
- ▶/◀ Slow motion playback -40-
- |||/◀||| Frame-by-frame playback -40-
- 2X▶▶ Variable-speed search -40-
- ↺▶ Repeat playback -39-
-  WEB: WEB CAMERA mode (Playback) -49-
- A.DUB ●: Audio dubbing -47-
- A.DUB ||: Audio dubbing pause -47-
- 12bit, 16bit: Audio recording mode -65-
- : Volume adjustment -39-

#### Card







- (White): Shutter chance mark -27-
- (Green): Shutter chance mark -27-
- : Self-timer recording -34-
-  MEGA: MEGA OIS -35-
-  (White): Photoshot mode
-  (Green): While the card is being read
-  (Red): While photoshot recording is activated
-  (Red): While the card is being accessed in PC Connection Mode
-  (Red flash): Using the card that cannot be recognised or no card is inserted
-  (18): Photoshot picture quality -28-
- 18: Remaining number of photoshot pictures (When the remaining number of photoshot pictures reaches 0, the red indication flashes.)
- : Slide show playback -42-
-  PictBridge: PictBridge mode -48-
- 100-0001: Folder/File display
- No.00: File number
-  1: Number of DPOF Setting -44-
- : Protect setting -44-
-  0.2M: [640×360] Image size
-  1M: [1280×720] Image size
-  2.4M: [2048×1152] Image size
-  0.3M: [640×480] Image size
-  1M: [1280×960] Image size
-  2M: [1600×1200] Image size
-  3.1M: [2048×1512] Image size

- For images not recorded with this unit, the number of horizontal and vertical pixels may differ so the image size is not displayed.



### Warning/alarm indications

If any one of the following indications lights up or flashes, please check the movie camera.

#### Confirmatory indications

- : A cassette with the accidental erasure prevention slider placed in the [SAVE] position is inserted.  
No cassette is inserted.
- : The built-in battery is low. -13-
- : The warning/alarm indication appears when you record yourself. Turn the LCD monitor towards the viewfinder and check the warning/alarm indication.
- : No card is inserted.
- REMOTE :  
An incorrect remote control mode has been selected. -23-
- END:  
The tape came to the end during recording.
- : The video heads are dirty. -73-

#### Textual indications

- DEW DETECT/EJECT TAPE:  
Condensation has occurred. Take out the cassette and wait for a while. It takes some time until the cassette holder opens, but this is not a malfunction. -72-
- LOW BATTERY:  
The battery is low. Recharge it. -9-
- NO TAPE:  
No tape is inserted. -15-
- TAPE END:  
The tape came to the end during recording.
- CHECK REC TAB:  
You are attempting to record pictures on a tape with the accidental erasure prevention slider placed in the [SAVE] position.  
You are attempting audio dubbing or digital dubbing on a tape with the accidental erasure prevention slider placed in the [SAVE] position.
- CHECK REMOTE MODE:  
An incorrect remote control mode has been selected. This is only displayed at the first operation of the remote control after powering-on. -23-

#### WRONG TAPE FORMAT:

You are attempting to play back a tape section that has been recorded with a different TV system. This cassette is incompatible.

#### UNPLAYABLE CARD:

You are attempting to play back data not compatible with this movie camera.

#### CLOSE CASSETTE DOOR:

The cassette cover is open. Close the cassette cover. -15-

#### UNABLE TO A.DUB (LP RECORDED):

Audio dubbing cannot be performed because the original recording was in LP mode.

#### UNABLE TO A.DUB:

You are attempting to perform audio dubbing on a non-recorded tape.

#### CANNOT RECORD IN AGS MODE:

The AGS function is activated. -33-

#### COPY PROTECTED:

Images cannot be recorded correctly because the medium is protected by a copy guard.

#### CARD ERROR:

This card is not compatible with this movie camera.

You are attempting to format a failed card. It displays, when you attempt to insert the incompatible card to Card Slot.

#### NO CARD:

No card is inserted.

#### CARD FULL:

Card does not have sufficient memory remaining.  
Select Card Playback Mode and delete unnecessary files.

#### NO DATA:

There are not any recorded files on the card.

#### FILE LOCKED:

You are attempting to erase protected files.

#### CARD LOCKED:

The write protection switch on the SD Card is set to [LOCK].

#### NEED HEAD CLEANING:

The video heads are dirty. -73-

#### PUSH THE RESET SWITCH:

An irregularity in the equipment has been detected. Press the [RESET] button (-71-). This may solve the problem.

**CHANGE MODE TO USE USB:**

The USB cable is connected to the movie camera in Card Recording Mode.

**DISCONNECT USB CABLE:**

You are attempting to turn the mode dial in PC Connection Mode with the USB cable connected to the movie camera. You are attempting to record pictures on a tape/card with the USB cable connected to the movie camera.

**NO INK IN PRINTER:**

There is no ink. Check the connected printer.

**NO PAPER IN PRINTER:**

There is no paper. Check the connected printer.

**PRINTER ERROR:**

Check the connected printer.

**PC DOES NOT SUPPORT USB2.0:**

The movie camera is connected to a personal computer that does not support USB 2.0. -54-

**CAN NOT USE USB:**

You are connecting the USB cable with the DV cable connected.

**CHANGE TO MANUAL MODE:**

You are attempting to select the item on the [SCENE MODE] when the [AUTO/MANUAL/FOCUS] switch is set to [AUTO].

**CAN NOT OPERATE (MOTION DV MODE):**

You are attempting to change [D.ZOOM] setting during MotionDV Mode.

***Functions cannot be used simultaneously***

Some functions in the movie camera are disabled or cannot be selected due to its specifications. The table below shows examples of functions restricted by conditions.

Functions	Conditions which disable the functions
<ul style="list-style-type: none"> <li>● Digital zoom</li> <li>● Fade</li> </ul>	<ul style="list-style-type: none"> <li>● When the Card Recording mode is used</li> </ul>
<ul style="list-style-type: none"> <li>● Backlight compensation</li> </ul>	<ul style="list-style-type: none"> <li>● When the colour night view function is used</li> <li>● When the iris/gain is set</li> </ul>
<ul style="list-style-type: none"> <li>● Help mode</li> <li>● Recording check</li> <li>● Blank search</li> <li>● Soft skin</li> <li>● Tele macro</li> </ul>	<ul style="list-style-type: none"> <li>● While recording to a tape</li> </ul>
<ul style="list-style-type: none"> <li>● Colour Night View</li> </ul>	<ul style="list-style-type: none"> <li>● While recording to a tape</li> <li>● When the Card Recording mode is used</li> </ul>
<ul style="list-style-type: none"> <li>● Scene mode</li> </ul>	<ul style="list-style-type: none"> <li>● When setting the [AUTO/MANUAL/FOCUS] switch to [AUTO]</li> <li>● When the colour night view function is used</li> </ul>
<ul style="list-style-type: none"> <li>● Change of white balance</li> </ul>	<ul style="list-style-type: none"> <li>● When digital zoom (10× or higher) is used</li> <li>● When the colour night view function is used</li> </ul>
<ul style="list-style-type: none"> <li>● Adjusting the shutter speed, iris/gain</li> </ul>	<ul style="list-style-type: none"> <li>● When the colour night view function is used</li> <li>● When the scene mode is used</li> </ul>
<ul style="list-style-type: none"> <li>● Variable-speed search</li> </ul>	<ul style="list-style-type: none"> <li>● During repeat playback</li> </ul>
<ul style="list-style-type: none"> <li>● Deleting files</li> </ul>	<ul style="list-style-type: none"> <li>● When the write protect switch on the card is set to [LOCK]</li> <li>● When the file is protected</li> </ul>
<ul style="list-style-type: none"> <li>● Formatting</li> </ul>	<ul style="list-style-type: none"> <li>● When the write protect switch on the card is set to [LOCK]</li> </ul>
<ul style="list-style-type: none"> <li>● Audio dubbing</li> </ul>	<ul style="list-style-type: none"> <li>● The section of a tape recorded in LP mode</li> <li>● The blank section of a tape</li> <li>● Sounds sent through the DV terminal</li> </ul>

## **Before requesting repair (Problems and solutions)**

### **Power/Body**

#### **1: The movie camera power cannot be turned on.**

- Is the battery fully charged? Use a fully charged battery.
- The battery protection circuit may have operated. Attach the battery to the AC adaptor for 5 to 10 seconds. If the movie camera still cannot be used, the battery is faulty.
- Is the LCD monitor opened or the viewfinder extended?

#### **2: The movie camera power is turned off automatically.**

- If you set [POWER SAVE] to [5 MINUTES] and do not operate the movie camera for about 5 continuous minutes, the power is automatically turned off for tape protection and power conservation. To resume recording, turn the [OFF/ON] switch to [OFF]. Then turn it to [ON] again. (-65-) Also, if you set [POWER SAVE] to [OFF], the power does not automatically turn off.

#### **3: The movie camera power does not stay on long enough.**

- Is the battery low? If the remaining battery power indication is flashing or the message "LOW BATTERY" is displayed, the battery has run down. Charge the battery or attach a fully charged battery. (-9-)
- Has condensation occurred? When you carry the movie camera from a cold place into a warm place, condensation may occur inside it. If so, the power is turned off automatically, disabling all operations except for taking cassettes out. Wait until the condensation indication disappears. (-72-)

#### **4: Battery runs down quickly.**

- Is the battery fully charged? Charge it with the AC adaptor. (-9-)
- Are you using the battery in an extremely cold place? The battery is affected by ambient temperature. In cold places, the operating time of the battery becomes shorter.
- Has the battery worn out? The battery has a limited life. If the operating time is still too short even after the battery is fully charged, depending on the usage, the battery has worn out and can no longer be used.

#### **5: The movie camera cannot be operated though powered up.**

##### **The movie camera does not operate normally.**

- The movie camera cannot be operated unless you open the LCD monitor or extend the viewfinder.
- Remove the cassette and the card and then press the [RESET] button. (-71-) If normal conditions are not restored yet, turn off the power. Then, about 1 minute later, turn on the power again. (Conducting the above operation when the access lamp is on may destroy the data on the card.)

#### **6: The cassette cannot be removed.**

- Does the Status indicator comes on when opening the cassette cover? (-15-) Make sure that the battery and the AC adaptor are properly connected. (-10-)
- Is the battery in use discharged? Charge the battery and remove the cassette.
- Close the cassette cover completely, and fully open it again. (-15-)

#### **7: No operation other than cassette removal can be performed.**

- Has condensation occurred? Wait until the condensation indication disappears. (-72-)

#### **8: The remote control does not function.**

- Has the button-type battery of the remote control run out? Replace it with a new button-type battery. (-22-)
- Is the setting on the remote control correct? If the setting on the remote control is not in agreement with the [REMOTE] setting on the movie camera, the remote control does not operate. (-23-)

## Recording

### 1: Recording does not start although power is supplied to the movie camera and the cassette is correctly inserted.

- Is the accidental erasure prevention slider on the cassette open? If it is open (set to [SAVE]), recording cannot be performed. (-15-)
- Is the tape wound to the end? Insert a new cassette.
- Is the recording mode set? When in the playback mode, recording cannot be performed. (-17-)
- Has condensation occurred? No operation other than cassette removal can be performed when condensation occurs. Wait until the condensation indication disappears. (-72-)
- Is the cassette cover open? If the cover is open, the movie camera may not operate normally. Close the cassette cover. (-15-)

### 2: The screen has changed suddenly.

- Has the demonstration started? In the Tape Recording mode, if you set [DEMO MODE] >> [ON] without inserting a cassette and a card, the demonstration starts. For normal use, set this function to [OFF]. (-65-)

### 3: A cassette cannot be inserted.

- Has condensation occurred? Wait until the condensation indication disappears.

### 4: Auto focus function does not work.

- Is manual focus mode selected? If auto focus mode is selected, focus is automatically adjusted.
- There are some recording subjects and surroundings for which the auto focus does not operate correctly. (-77-) If so, use the manual focus mode to adjust the focus. (-37-)

### 5: The camera arbitrarily stops recording.

- Is the AGS function activated? Record in the normal horizontal position or set [AGS] to [OFF]. (-33-)

## Indications

### 1: A sentence is displayed in red in the screen centre.

- Read the contents and respond to them. (-67-)

### 2: The time code becomes inaccurate.

- The time code indication counter may not be constant in the reversed slow-motion playback, but this is not a malfunction.

### 3: The remaining tape time indication disappears.

- The remaining tape time indication may disappear temporarily during frame-by-frame playback or other operation. If you continue ordinary recording or playback, the indication is restored.

### 4: The remaining tape time indication does not match the actual remaining tape time.

- If scenes of less than 15 seconds are continuously recorded, the remaining tape time cannot be correctly displayed.
- In some cases, the remaining tape time indication may show remaining tape time that is 2 to 3 minutes shorter than the actual remaining tape time.

### 5: A function indication such as mode indication, remaining tape time indication, or time code indication is not shown.

- If you set [SETUP] >> [DISPLAY] >> [OFF], indications other than the tape running condition, warning, and date indications disappear.

## Playback (Sound)

### 1: Sound is not played back from the built-in speaker of the movie camera.

- Is the volume too low? During playback, push the [-  /VOL+] lever to display the volume indication and adjust it. (-39-)

### 2: Different sounds are reproduced at the same time.

- Have you set [SETUP] >> [12bit AUDIO] >> [MIX]? If you set [AUDIO REC] >> [12bit] and dub audio to a recorded tape, you can hear the sound on recording and the sound dubbed at a later time. To hear the sounds separately, set to [ST1] or [ST2]. (-48-)
- Have you set [SETUP] >> [AUDIO OUT] >> [STEREO] and reproduced a picture containing the main sound and sub sound? Set to [L] to hear main sound, and set to [R] to hear the sub sound. (-65-)

### 3: Audio dubbing cannot be performed.

- Is the accidental erasure prevention slider on the cassette open? If it is open (set to [SAVE]), audio dubbing cannot be performed. (-15-)
- Are you attempting to edit a tape portion that was recorded in LP mode? LP mode does not allow audio dubbing. (-24-)

### 4: The original sound was erased when audio dubbing was performed.

- If you perform audio dubbing on a recording made in [16bit] mode, the original sound will be erased. If you wish to preserve the original sound, be sure to select [12bit] mode when recording.

### 5: Sounds cannot be played back.

- Although a cassette with no audio dubbing is being played, have you set [SETUP] >> [12bit AUDIO] >> [ST2]? To play back a cassette with no audio dubbing, set [12bit AUDIO] >> [ST1]. (-48-)

- Is the variable speed search function working? Press the [VAR SEARCH] button on the remote control to cancel the variable speed search function. (-40-)

### Playback (Pictures)

**1: Although the movie camera is correctly connected to a TV, playback images cannot be seen.**

**The images are vertical.**

- Have you selected video input on the TV? Please read the operating instructions of your TV and select the channel that matches the input terminals used for the connection.
- Is the [TV ASPECT] setting correct? Change the setting to match the aspect ratio of the TV. [SETUP] >> [TV ASPECT] >> [16:9] or [4:3].

**2: Mosaic-pattern noise appears on images during cue or review playback.**

- This phenomenon is characteristic of digital video systems. It is not a malfunction.

**3: Horizontal stripes appear on images during cue and review playback.**

- Horizontal stripes may appear depending on the scene, but this is not a malfunction.

**4: Playback picture is not clear.**

- Are the heads of the movie camera dirty? If the heads are dirty, playback image cannot be clear. Clean the heads by using the head cleaner for digital video (Supplied). (-73-)
- If the terminal for the Multi cable is soiled, noises may appear on the screen. Wipe the soil off the terminal with a soft cloth, and then connect the cable to the A/V terminal.
- Is a picture containing a copyright protection signal (copy guard) being recorded? When a protected picture is played back by the movie camera, mosaic-like patterns appear on the picture.

### Card

**1: Recorded pictures are not clear.**

- Have you set [BASIC] >> [PICT.QUALITY] >> [ . . . ]? If recording is done with it set to [ . . . ], pictures with fine details may include a mosaic-like pattern. Set [PICT.QUALITY] >> [ . . . ]. (-28-)

**2: A file recorded on a card cannot be deleted.**

- Is the file protected? Protected files cannot be deleted. (-44-)
- For the SD Card, if its write protect switch is set to [LOCK], then deletion is disabled. (-16-)

**3: Photoshot playback images do not look normal.**

- The picture may be damaged. In order to prevent the loss of image data, backing up on a

cassette or a personal computer is recommended.

**4: Even if a card is formatted, it cannot be used.**

- Either the movie camera or the card may be damaged. Please consult a dealer. Use an SD Card from 8 MB to 4 GB with this unit.

**5: During playback, [UNPLAYABLE CARD] is displayed.**

- The image was either recorded in a different format, or data is damaged.

**6: If the SD card is inserted in another device, it is not recognised.**

- Check that the device is compatible with the capacity or type of SD card (SD Memory Card/SDHC Memory Card) that you inserted. (-16-) Refer to the operating instructions of the device for details.

### Others

**1: The indication disappears, the screen is frozen, or no operation can be performed.**

- Turn off the power to the movie camera. If the power cannot be turned off, press the [RESET] button, or detach the battery or AC adaptor and then reattach it. After that, turn on the power again. If normal operation is still not restored, detach the power connected, and consult the dealer who you purchased the movie camera from.

**2: "PUSH THE RESET SWITCH" is displayed.**

- An irregularity in the movie camera has been automatically detected. Remove the cassette or the card for data protection and then press the [RESET] button with the boss **A**. The movie camera will be activated.

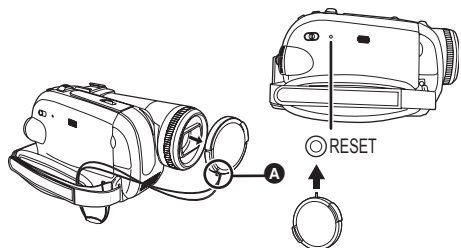



- If you do not press the [RESET] button, the power to the movie camera is turned off automatically about 1 minute later.
- Even after you press the [RESET] button, the indication may still appear repeatedly. If so, the movie camera needs repair. Detach the power connected, and consult the dealer who you purchased the movie camera from. Do not attempt to repair the appliance by yourself.

**3: Even if connected by the USB cable, the movie camera is not recognised by the PC.**

- Is the USB driver installed? -53-

**4: When the USB cable is disconnected, an error message will appear on PC.**

- To disconnect the USB cable safely, double-click the  () icon in the task tray and follow the instructions on the screen.

**5: The movie camera malfunctions on editing, dubbing from digital video equipment, or using "MotionDV STUDIO 6.0E LE for DV" or "SweetMovieLife".**

- If a tape is recorded in multiple modes such as SP and LP (recording mode), 12bit and 16bit (sound recording mode), 4:3 and wide, recorded and unrecorded parts, the movie camera may malfunction at a point where the mode switches. When you edit, do not record in multiple modes.

**6: Cannot see the PDF operating instructions for SweetMovieLife/MotionDV STUDIO.**

- Is Adobe Acrobat Reader 5.0 or later or Adobe Reader 7.0 or later installed on the computer that you are using? You will need Adobe Acrobat Reader 5.0 or later or Adobe Reader 7.0 or later to read the PDF operating instructions for SweetMovieLife/MotionDV STUDIO.



**7: The warning/alarm indication [] appears when the camera is operated in the WEB camera mode.**

- Did you press the menu button or the recording start/stop button? You cannot use the menu or record onto the tape/card in the WEB camera mode.
- Is the setting for the remote control correct?
- Did you attempt to play a tape without inserting it? Insert a tape.
- Did you attempt to play a tape with copyright protection (copy guard)? Pictures of the tape with copyright protection (copy guard) cannot be displayed on the PC. (The audio of the tape can be played.)
- Is the USB driver installed? -53-

**Cautions for Use**

In the event of abnormal operation (e.g. if the unit emits smoke or an unusual smell), immediately stop operating the unit and consult the Panasonic Customer Care Centre on 132600.

**■ About condensation**

If you turn the movie camera on when condensation occurs on the head or the tape, condensation Indication [] (yellow or red) is displayed on the viewfinder or the LCD monitor and the messages [] DEW DETECT] or [] EJECT TAPE] (only when the tape is inserted) appear. If so, follow the procedure below.

**1 Remove the tape if it is inserted.**

- It takes about 20 seconds to open the cassette holder. This is not a malfunction.

**2 Leave the movie camera with the cassette cover closed to cool or warm it to the ambient temperature.**

- The Status indicator blinks for about 1 minute and then the movie camera automatically turns off. Leave it for about 1.5 to 2 hours.

**3 Turn the movie camera on again, set it to the Tape Recording/Playback Mode and then check if the condensation indication disappears.**

Especially in cold areas, moisture may be frozen. If so, it may take more time before the condensation indication disappears.

**Watch for condensation even before the condensation Indication is displayed.**

- If the indicator of the condensation does not display on the LCD monitor and/or viewfinder and you notice condensation on the lens or the main unit, do not open the cassette cover otherwise condensation may be formed on the heads or the cassette tape.

**When the lens is fogged:**

Set the [OFF/ON] switch to [OFF] and leave the movie camera in this condition for about 1 hour. When the lens temperature becomes close to the ambient temperature, the fogging disappears naturally.



### ■ About dirty heads

If video heads (the parts that closely contact with the tape) become dirty, normal recording and playback are not properly performed. Clean the heads with the digital video head cleaner.

- Insert the head cleaner into the movie camera, set it to the Tape Playback Mode, and play it back for about 10 seconds. (If you do not stop the playback, it automatically stops about 15 seconds later.)

- We recommend cleaning the heads periodically.

If the heads become dirty, “NEED HEAD CLEANING” appears during recording. During playback, moreover, the following symptoms appear.

- Mosaic-like noise appears partially or the sound is interrupted.
- Black or blue mosaic-like horizontal stripes appear.
- The whole screen becomes black and there is no picture and sound.

### When normal playback cannot be performed even after the head cleaning

One possible cause is that normal recording could not be performed because the heads were dirty at the time of recording. Clean the heads, and perform recording and playback again. If normal playback can be performed, the heads are clean. Before an important recording, be sure to conduct a test recording to make sure that normal recording can be performed.

- If the heads become dirty soon after cleaning, the problem may be attributable to the tape. If so, try another cassette.
- During playback, the picture or sound may be interrupted momentarily, but this is not a malfunction of the movie camera. (One possible cause is that the playback is interrupted by dirt or dust that momentarily adheres to the heads.)

### ■ About the movie camera

- When the movie camera is used for a long time, the camera body becomes warm, but this is not a malfunction.

**Keep the Digital Video Camera as far away as possible from electromagnetic equipment (such as microwave ovens, TVs, video games etc.).**

- If you use the Digital Video Camera on top of or near a TV, the pictures and sound on the Digital Video Camera may be disrupted by electromagnetic wave radiation.
- Do not use the Digital Video Camera near cell phones because doing so may result in noise adversely affecting the pictures and sound.
- Recorded data may be damaged, or pictures may be distorted, by strong magnetic fields created by speakers or large motors.
- Electromagnetic wave radiation generated by microprocessors may adversely affect the Digital Video Camera, disturbing the pictures and sound.
- If the Digital Video Camera is adversely affected by electromagnetic equipment and stops functioning properly, turn the Digital Video Camera off and remove the battery or disconnect AC adaptor. Then reinsert the battery or reconnect AC adaptor and turn the Digital Video Camera on.

**Do not use the Digital Video Camera near radio transmitters or high-voltage lines.**

- If you record near radio transmitters or high-voltage lines, the recorded pictures and sound may be adversely affected.

**Do not spray insecticides or volatile chemicals onto the movie camera.**

- If the movie camera is sprayed with such chemicals, the camera body may become deformed and the surface finish may peel off.
- Do not keep rubber or plastic products in contact with the movie camera for a long time.

**When you use your movie camera in a sandy or dusty place such as on a beach, do not let sand or fine dust get into the body and terminals of the movie camera. Also, protect the movie camera from getting wet.**

- Sand or dust may damage the movie camera or cassette. (Care should be taken when inserting and removing a cassette.)
- If sea water splashes onto the movie camera, wet a soft cloth with tap water, wring it well, and use it to wipe the camera body carefully. Then, wipe it again thoroughly with a soft dry cloth.

**While carrying the movie camera, do not drop or bump it.**

- A strong impact on the movie camera may break its housing, causing it to malfunction.

**Do not use benzine, paint thinner or alcohol for cleaning the movie camera.**

- Before cleaning, detach the battery or pull out the AC mains lead from the AC mains socket.
- The camera body may be discoloured and the surface finish may peel off.
- Wipe the movie camera with a soft dry cloth to remove dust and fingerprints. To remove stubborn stains, wring well a cloth that is soaked in a neutral detergent diluted with water and wipe the movie camera with it. Afterwards, wipe it with a dry cloth.
- When you use a chemical dust cloth, follow the instructions.

**Do not use this movie camera for surveillance purposes or other business use.**

- If you use the movie camera for a long time, the internal temperature increases and, consequently, this may cause malfunction.
- This movie camera is not intended for business use.

**When you are not going to use movie camera for an extended time**

- When storing the unit in a cupboard or a cabinet, it is recommended that you put a desiccant (silica gel) in with it.

**■ About the battery**

The battery used in the movie camera is a rechargeable lithium ion battery. This battery is susceptible to temperature and humidity, and the effect of temperature increases with increasing or decreasing temperature. In the low temperature range, the fully charged indication may not appear, or the low battery indication may appear about 5 minutes after the start of use. At high temperature, moreover, the protection function may work, disabling use of the movie camera.

**Be sure to detach the battery after use**

- If the battery is left attached to the movie camera, a minute amount of current is consumed even when the movie camera power is [OFF]. If the battery is left attached to the movie camera for a long time, over-discharge takes place. The battery may become unusable after it is charged.
- The battery should be stored in a cool place free from humidity, with as constant temperature as possible. (Recommended temperature: 15 °C to 25 °C, Recommended humidity: 40% to 60%)
- Extremely high temperatures or low temperatures will shorten the life of the battery.
- If the battery is kept in a high-temperature, high-humidity, or oily-smoky places, the terminals may rust and cause malfunctions.
- To store the battery for a long period of time, we recommend you charge it once every year and store it again after you have completely used up the charged capacity.
- Dust and other matter attached to the battery terminals should be removed.

**Prepare spare batteries when going out for recording.**

- Prepare batteries appropriate to 3 to 4 times the period during you want to record pictures in. In cold places such as a ski resort, the period during which you can record pictures is shortened.
- When you travel, do not forget to bring an AC adaptor so that you can recharge the batteries at your destination.

**If you drop the battery accidentally, check to see if the terminals are deformed.**

- Attaching a deformed battery to the movie camera or AC adaptor may damage the movie camera or AC adaptor.

**Do not throw old battery into fire.**

- Heating a battery or throwing it into a fire may result in an explosion.
- If the operating time is very short even after the battery has been recharged, the battery has worn out. Please purchase a new battery.

### ■ About the AC adaptor

- If the battery is warm, charging requires more time than normal.
- If the temperature of the battery is extremely high or extremely low, the [CHARGE] lamp may continue flashing, and the battery may not be charged. After the battery temperature has decreased or increased sufficiently, recharging starts automatically. So, wait for a while. If the lamp still continues flashing even after the recharging, the battery or AC adaptor may be faulty. If so, please contact a dealer.
- If you use the AC adaptor near a radio, radio reception may be disturbed. Keep the AC adaptor 1 metre or more away from radio.
- When using the AC adaptor, it may generate whirring sounds. However, this is normal.
- After use, be sure to pull out the AC mains lead from the AC mains socket. (If they are left connected, a minute amount of current is consumed.)
- Always keep the electrodes of the AC adaptor and battery clean.

### ■ About the cassette

**Never place the cassette in a high temperature place.**

- The tape may be damaged, producing mosaic-like noise at the time of playback.

**When storing the cassette after use, be sure to rewind the tape to the beginning and take it out.**

- If the cassette is left for more than 6 months (depending on the storage condition) in the movie camera or stopped midway, the tape may sag and be damaged.
- Once every 6 months, wind the tape to the end and then rewind it to the beginning. If the cassette is left for 1 year or longer without winding or rewinding, the tape may be deformed by expansion or shrinkage attributable to temperature and humidity. The wound tape may stick to itself.
- Dust, direct sunlight (ultraviolet rays), and humidity may damage the tape. Such usage may cause damage to the movie camera and the heads.
- After use, be sure to rewind the tape to the beginning, put the cassette in the case to protect it from dust, and store it upright.

**Keep the cassette away from strong magnetism.**

- Apparatuses using magnets such as magnetic necklaces and toys have magnetic force that is stronger than expected, and they may erase the contents of a recording or may increase noise.

### ■ About the card

**When inserting or removing the card, always set the [OFF/ON] switch to [OFF].**

**When the access lamp is illuminated (During access to the card), do not pull out the card, rotate the mode dial, turn off the power, or cause any vibrations or impact.**

**Do not leave the card in places where there is high temperature or direct sunlight, or where electromagnetic waves or static electricity are easily generated. Moreover, do not fold or drop the card, and do not strongly vibrate it.**

- The card may break or the contents of the card may be destroyed or erased.
- Do not touch the terminals on the back of the card.
- Electrical noise, static electricity, or failure of the movie camera or the card may damage or erase the data stored on the card. We recommend saving important data on a personal computer by using a USB cable, PC card adaptor, and USB reader/writer.

**After use, be sure to remove the card from the movie camera for storage.**

- After use, or when storing or carrying the card, put it in the storage case.
- Do not allow dust, water, or foreign substances to adhere to the terminals on the back of the card. Moreover, do not touch the terminals with your hand.
- Keep the Memory Card out of reach of children to prevent swallowing.

### ■ Folder structure of the card

**The folder structure of the card formatted by the movie camera will be displayed on the PC as the illustration below.**

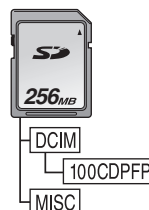

- Up to 999 pictures can be recorded on 100CDPFP folder etc.
- Files with the DPOF settings can be recorded on MISC folder.

## ■ LCD monitor/viewfinder

### LCD monitor

- When the LCD monitor gets dirty, wipe it with a dry soft cloth.
- In a place with drastic temperature changes, condensation may form on the LCD monitor. Wipe it with soft dry cloth.
- If your movie camera is extremely cold, the LCD monitor is slightly darker than usual immediately after you turn the power on. However, as the internal temperature increases, it goes back to normal brightness.

Extremely high precision technology is employed to produce the LCD monitor screen featuring a total of approximately 123,000 pixels. The result is more than 99.99% effective pixels with a mere 0.01% of the pixels inactive or always lit. However, this is not a malfunction and does not affect the recorded picture.

### Viewfinder

Extremely high precision technology is employed to produce the viewfinder screen featuring a total of approximately 113,000 pixels. The result is more than 99.99% effective pixels with a mere 0.01% of the pixels inactive or always lit. However, this is not a malfunction and does not affect the recorded picture.

## ■ Periodical check-ups

- To maintain the highest image quality, we recommend replacing worn parts such as heads after approx. 1000 hours of use. (This, however, depends on operating conditions including temperature, humidity and dust.)

## Explanation of terms

### ■ Automatic white balance

White balance adjustment recognises the colour of light and adjusts so the white colour will become a pure white. The movie camera determines the hue of light that comes through the lens and white balance sensor, thereby judging the recording condition, and selects the closest hue setting. This is called automatic white balance adjustment. However, since the movie camera only stores white colour information under several light sources, automatic white balance adjustment does not function normally under the other light sources.

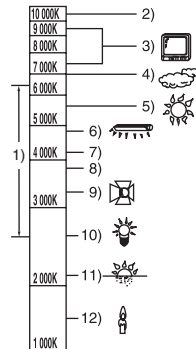

Outside of the effective range of automatic white balance adjustment, the image will become reddish or bluish. Even within the effective range of automatic white balance adjustment, the automatic white balance adjustment may not function properly if there is more than one light source. For light outside the functional auto white balance adjustment range, use the manual white balance adjustment mode.

- 1) The effective range of automatic white balance adjustment on this movie camera
- 2) Blue sky
- 3) TV screen
- 4) Cloudy sky (rain)
- 5) Sunlight
- 6) White fluorescent lamp
- 7) 2 hours after sunrise or before sunset
- 8) 1 hour after sunrise or before sunset
- 9) Halogen light bulb
- 10) Incandescent light bulb
- 11) Sunrise or sunset
- 12) Candlelight

### ■ White balance

The image recorded by the movie camera may become bluish or reddish under the influence of light sources. To avoid such phenomena, adjust the white balance.

White balance adjustment determines the white colour under different light sources. By recognizing which is the white colour under sunlight and which is the white colour under a fluorescent lamp, the movie camera can adjust the balance among the other colours.

Since white colour is the reference of all colours (light), the movie camera can record pictures in a natural hue if it can recognise the reference white colour.

### ■ Auto focus

Auto focus automatically moves the focusing lens forward and backward inside the movie camera to bring the subject into focus.

**Auto focus has the following characteristics.**

- Adjusts so that the vertical lines of a subject are seen more clearly.
- Attempts to bring an object with higher contrast into focus.
- Focuses on the screen centre only.

Due to these characteristics, auto focus does not work correctly in the following situations. Record pictures in the manual focus mode.

### **Recording a subject with one end located closer to the movie camera and the other end farther away from it**

- As auto focus adjusts at the centre of an image, it may be impossible to focus on a subject that is located in both the foreground and background.

### **Recording a subject behind dirty or dusty glass**

- The subject behind the glass will not be focused because the focus is on the dirty glass.

### **Recording a subject that is surrounded by objects with glossy surfaces or by highly reflective objects**

- The recording subject may become blurry because the movie camera focuses on the objects with glossy surfaces or on highly reflective objects.

### **Recording a subject in dark surroundings**

- The movie camera cannot focus correctly because the light information that comes through the lens decreases considerably.

### **Recording a fast-moving subject**

- As the focus lens-inside moves mechanically, it cannot keep up with a fast-moving subject.

### **Recording a subject with little contrast**

- A subject with little contrast, such as a white wall, may become blurry because the movie camera achieves focus based upon the vertical lines of an image.

## Specifications

### Specifications

#### Digital Video Camera

Information for your safety

**Power source:**

DC 7.9/7.2 V

**Power consumption:**

Recording  
5.2 W

**Recording format:**

Mini DV (Consumer-use digital video SD format)

**Tape used:**

6.35 mm digital video tape

**Recording/playback time:**

SP: 80 min; LP: 120 min (with DVM80)

**Video**
**Recording system:**

Digital component

**Television system:**

CCIR: 625 lines, 50 fields PAL colour signal

**Audio**
**Recording system:**

PCM digital recording  
16 bit (48 kHz/2 ch), 12 bit (32 kHz/4 ch)

**Image sensor:**

1/6-inch 3CCD image sensor  
[Effective pixels]  
Moving picture: 630 KX3 (4:3), 540 KX3 (16:9)/  
Still picture: 710 KX3 (4:3), 540 KX3 (16:9)/  
Total: 800 KX3

**Lens:**

Auto Iris, F1.8 to F2.8, Focal length; 3.0 mm to  
30.0 mm, Macro (Full range AF)

**Filter diameter:**

37 mm

**Zoom:**

10:1 Power zoom

**Monitor:**

2.7-inch LCD

**Viewfinder:**

Colour electronic viewfinder

**Microphone:**

Stereo (with a zoom function)

**Speaker:**

1 round speaker  $\varnothing$  20 mm

**Standard illumination:**

1,400 lx

**Minimum required illumination:**

8 lx (Low light mode: 1/50)  
1 lx (Colour Night View Mode)

**Video output level:**

1.0 Vp-p, 75  $\Omega$

**S-Video output level:**

Y Output: 1.0 Vp-p, 75  $\Omega$   
C Output: 0.3 Vp-p, 75  $\Omega$

**Audio output level (Line):**

316 mV, 600  $\Omega$

**USB:**

Card reader/writer function, USB port (Hi-Speed  
USB(USB 2.0))  
No copyright protection support  
PictBridge-compliant

**Digital interface:**

DV input/output terminal (IEEE1394, 4-pin)

**Dimensions**

78.5 mm (W)X72.6 mm (H)X136.0 mm (D)  
(excluding the projecting parts)

**Mass:**

Approx. 450 g (without supplied battery and DV  
cassette)  
Approx. 515 g (with supplied battery and DV  
cassette)

**Operating temperature:**

0 °C to 40 °C

**Operating humidity:**

10% to 80%

**Card memory functions**
**Recording media:**

SD Memory Card: 8 MB/16 MB/32 MB/64 MB/  
128 MB/256 MB/512 MB/1 GB/2 GB (Maximum)  
(FAT12 and FAT16 format corresponding)  
SDHC Memory Card: 4 GB (Maximum)  
(FAT32 format corresponding)

Please confirm the latest information on the  
following website.

<http://panasonic.co.jp/pavc/global/cs>

(This Site is English only.)

**Still picture recording file format:**

JPEG (Design rule for Camera File system, based  
on Exif 2.2 standard), DPOF corresponding

**Still picture size:**

2048X1512  
2048X1152  
1600X1200  
1280X960  
1280X720  
640X480  
640X360

**WEB camera**
**Compression:**

Motion JPEG

**Image size:**

320X240 pixels (QVGA)

**Frame rate:**

Approx. 6 fps

**AC adaptor VSK0651**

Information for your safety

**Power source:**

AC 110 V to 240 V, 50/60 Hz

**Power consumption:**

19 W

**DC output:**

DC 7.9 V, 1.4 A (Movie camera operation)

DC 8.4 V, 0.65 A (Battery charging)

**Dimensions:**

61 mm (W)×32 mm (H)×91 mm (D)







**Mass:**

Approx. 110 g









Specifications may change without prior notice.

**Maximum number of still pictures recordable on an SD Card (optional)**

**16:9 mode:**

PICTURE SIZE	0.2M		1M *		2.4M	
						
8 MB	45	95	12	19	4	7
16 MB	100	200	29	46	11	18
32 MB	220	440	64	98	24	39
64 MB	440	880	130	200	51	81
128 MB	880	1760	250	390	99	155
256 MB	1760	3520	530	810	210	330
512 MB	3520	7040	1040	1600	410	650
1 GB	7040	14080	2090	3200	820	1290
2 GB	14080	28160	4250	6510	1680	2630
4 GB	28160	56320	8350	12780	3290	5170

**4:3 mode:**

PICTURE SIZE	0.3M		1M		2M		3.1M	
								
8 MB	45	95	9	15	5	9	3	5
16 MB	100	200	21	35	13	21	8	13
32 MB	220	440	47	75	30	47	18	29
64 MB	440	880	98	155	63	98	39	62
128 MB	880	1760	185	300	120	185	75	120
256 MB	1760	3520	390	620	250	390	160	250
512 MB	3520	7040	780	1230	500	780	320	490
1 GB	7040	14080	1550	2470	1010	1550	630	990
2 GB	14080	28160	3160	5030	2050	3160	1290	2010
4 GB	28160	56320	6210	9870	4020	6210	2530	3950

- \* is displayed only in Tape Recording Mode.
- The numbers shown in the table are approximations.
- These figures vary depending on the subject being photographed.



VQT1L48  
F1207RA0 ( 500 Ⓐ)



**Matsushita Electric Industrial Co., Ltd.**  
Web site: <http://panasonic.net>