

Panasonic®



Operating Instructions <Quick Start Guide> Digital Camera

LUMIX

Model No. **DC-GH5M2**

Please read these instructions carefully before using this product, and save this manual for future use.

More detailed operating instructions are available in “Operating Instructions <Complete Guide>” (HTML format / PDF format).

<https://panasonic.jp/support/dsc/oi/GH5M2/index.html>



Operating Instructions <Quick Start Guide>

Digital Camera

Dear Customer,

We would like to take this opportunity to thank you for purchasing this Panasonic Digital Camera. Please read this document carefully and keep it handy for future reference. Please note that the actual controls and components, menu items, etc. of your Digital Camera may look somewhat different from those shown in the illustrations in this document.

Carefully observe copyright laws.

Recording of pre-recorded tapes or discs or other published or broadcast material for purposes other than your own private use may infringe copyright laws. Even for the purpose of private use, recording of certain material may be restricted.

About Operating Instructions

❖ Operating Instructions <Quick Start Guide> (This document)

Explains the preparation before recording.



❖ Operating Instructions <Complete Guide> (HTML format / PDF format)

Explains all functions and operation methods in detail.
This can be viewed with a PC or smartphone.





<https://panasonic.jp/support/dsc/oi/GH5M2/index.html>

URL and QR code can also be checked on the [Online Manual] of the [Setup] menu.



❖ Symbols Used in This Document

In this document, camera operation is explained using the following symbols:

	Cursor button up/down/left/right or Joystick up/down/left/right
	Press the center of the joystick
	[MENU/SET] button

- Images and illustrations used in this document are for explaining the functions.
- Description in this document is based on the interchangeable lens (H-ES12060).

Contents

About Operating Instructions	3
Information for Your Safety.....	5
Cautions for Use	7

Introduction

Before Use.....	10
Standard Accessories	12
Names of Parts.....	14
Camera	14
Viewfinder / Monitor Displays.....	19

Getting Started / Basic Operations

Attaching a Shoulder Strap	20
Charging the Battery	21
Inserting Cards (Optional)	25
Attaching a Lens.....	27
Adjusting the Monitor Direction and Angle.....	28
Setting the Clock (When Turning On for the First Time).....	28
Menu Operation Methods.....	29

Materials

Message Displays.....	30
Troubleshooting.....	31
Specifications	33
Trademarks and Licenses.....	43

Information for Your Safety

WARNING:

To reduce the risk of fire, electric shock or product damage,

- Do not expose this unit to rain, moisture, dripping or splashing.
- Use the recommended accessories.
- Do not remove covers.
- Do not repair this unit by yourself. Refer servicing to qualified service personnel.

The socket outlet shall be installed near the equipment and shall be easily accessible.

■ Product identification marking

Product	Location
Digital camera	Bottom
Battery charger	Bottom

■ About the battery pack

CAUTION

- Danger of explosion if battery is incorrectly replaced. Replace only with the type recommended by the manufacturer.
 - When disposing of the batteries, please contact your local authorities or dealer and ask for the correct method of disposal.
-
- Do not heat or expose to flame.
 - Do not leave the battery(ies) in a car exposed to direct sunlight for a long period of time with doors and windows closed.
 - Do not expose to low air pressure at high altitudes.
 - Do not expose to extremely low air pressure, as this may result in explosions or leakage of flammable liquids and gases.

Warning

Risk of fire, explosion and burns. Do not disassemble, heat above 60 °C or incinerate.

■ About the AC adaptor (supplied)

CAUTION!

To reduce the risk of fire, electric shock or product damage,

- **Do not install or place this unit in a bookcase, built-in cabinet or in another confined space. Ensure this unit is well ventilated.**
-
- The AC adaptor is in the standby condition when the mains plug is connected. The primary circuit is always "live" as long as the mains plug is connected to an electrical outlet.

Cautions for Use

- Do not use any other USB connection cables except the one supplied with the camera or the battery charger (DMW-BTC15: optional).
- Always use a genuine Panasonic Shutter Remote Control (DMW-RS2: optional).
- Always use a genuine Panasonic Tripod Grip (DMW-SHGR1: optional).
- Use a "High Speed HDMI cable" with the HDMI logo.
Cables that do not comply with the HDMI standards will not work.
"High Speed HDMI cable" (Type A–Type A plug, up to 1.5 m (4.9 feet) long)
- Do not use the headphone cables with the length of 3 m (9.8 feet) or more.
- Do not use the stereo microphone cables with the length of 3 m (9.8 feet) or more.
- Do not use the synchro cables with the length of 3 m (9.8 feet) or more.

Keep this unit as far away as possible from electromagnetic equipment (such as microwave ovens, TVs, video games etc.).

- If you use this unit on top of or near a TV, the pictures and/or sound on this unit may be disrupted by electromagnetic wave radiation.
- Do not use this unit near cell phones because doing so may result in noise adversely affecting the pictures and/or sound.
- Recorded data may be damaged, or pictures may be distorted, by strong magnetic fields created by speakers or large motors.
- Electromagnetic wave radiation may adversely affect this unit, disturbing the pictures and/or sound.
- If this unit is adversely affected by electromagnetic equipment and stops functioning properly, turn this unit off and remove the battery or disconnect AC adaptor. Then reinsert the battery or reconnect AC adaptor and turn this unit on.

Do not use this unit near radio transmitters or high-voltage lines.

- If you record near radio transmitters or high-voltage lines, the recorded pictures and/or sound may be adversely affected.
-

- **Before cleaning the camera, remove the battery or the DC coupler (DMW-DCC17: optional), or disconnect the power plug from the outlet.**
 - **Do not press the monitor with excessive force.**
 - **Do not press the lens with excessive force.**
 - **Do not spray the camera with insecticides or volatile chemicals.**
 - **Do not keep rubber or plastic products in contact with the camera for a long period of time.**
 - **Do not use solvents such as benzine, thinner, alcohol, kitchen detergents, etc., to clean the camera, since it may deteriorate the external case or the coating may peel off.**
 - **Do not leave the camera with the lens facing the sun, as rays of light from the sun may cause it to malfunction.**
 - **Always use the supplied cords and cables.**
 - **Do not extend the cords or the cables.**
 - **During access (image writing, reading and deleting, formatting etc.), do not turn this unit off, remove the battery, card or disconnect the AC adaptor. Furthermore, do not subject the camera to vibration, impact or static electricity.**
 - **The data on the card may be damaged or lost due to electromagnetic waves, static electricity or breakdown of the camera or the card. We recommend storing important data on a PC etc.**
 - **Do not format the card on your PC or other equipment. Format it on the camera only to ensure proper operation.**
-

- **The battery is not charged when the camera is shipped. Charge the battery before use.**
- **The battery is a rechargeable lithium ion battery. If the temperature is too high or too low, the operating time of the battery will become shorter.**
- The battery becomes warm after using and during and after charging. The camera also becomes warm during use. This is not a malfunction.
- **Do not leave any metal items (such as clips) near the contact areas of the power plug or near the batteries.**
- Store the battery in a cool and dry place with a relatively stable temperature: (Recommended temperature: 15 °C to 25 °C (59 °F to 77 °F), Recommended humidity: 40 %RH to 60 %RH)
- **Do not store the battery for a long time while fully charged.** When storing the battery for a long period of time, we recommend charging it once a year. Remove the battery from the camera and store it again after it has completely discharged.

-If you see this symbol-



Disposal of Old Equipment and Batteries Only for European Union and countries with recycle systems

These symbols are only valid in the European Union and countries with recycle systems.

If you wish to discard this product, please contact your local authorities or dealer and ask for the correct method of disposal.

Introduction

Before Use

❖ Firmware of Your Camera/Lens

Firmware updates may be provided in order to improve camera capabilities or to add functionality.

Make sure that the firmware of the camera / lens you purchased is the latest version. We recommend using the latest firmware version.

- To check the firmware version of the camera/lens, attach the lens to the camera and select [Firmware Version] in the [Setup] ([Others]) menu. You can also update the firmware in [Firmware Version].
- For the latest information on the firmware or to download/update the firmware, visit the following support site:
<https://panasonic.jp/support/global/cs/dsc/>
(English only)



- This document provides explanations for camera firmware version 1.0. Refer to "Operating Instructions <Complete Guide>" for the changes after a firmware update. (→3)

❖ Handling of the Camera

When using the camera, take care not to drop it, bump it, or apply undue force. These may cause malfunction or damage to the camera and lens.

If sand, dust, or liquid gets on the monitor, wipe it off with a dry soft cloth.

- Touch operations may be incorrectly recognized.

When using in low temperatures (–10 °C to 0 °C (14 °F to 32 °F))

- Before use, attach a Panasonic lens with a minimum recommended operating temperature of –10 °C (14 °F).

Do not place a hand inside the camera mount.

This may cause a failure or damage because the sensor is a precision device.

The sensor can move, making a rattling noise, when the camera is shaken while it is off. This is caused by the image stabilizer mechanism in the body. It is not a malfunction.

❖ Splash Resistant

Splash Resistant is a term used to describe an extra level of protection this camera offers against exposure to a minimal amount of moisture, water or dust. **Splash Resistant does not guarantee that damage will not occur if this camera is subjected to direct contact with water. In order to minimize the possibility of damage please be sure the following precautions are taken:**

- Splash Resistant works in conjunction with the lenses that were specifically designed to support this feature.
- Securely close the doors, socket caps, contact points cover, etc.
- When the lens or cap is removed or a door is open, do not allow sand, dust, and moisture to enter inside.
- If liquid gets on the camera, wipe it off with a dry soft cloth.

❖ Condensation (When the Lens, the Viewfinder or Monitor is Fogged Up)

- Condensation occurs when there are temperature or humidity differences. Take care as this may lead to soiling, mold, and malfunctions in the lens, viewfinder, and monitor.
- If condensation occurs, turn off the camera and leave it for approx. 2 hours. The fog will disappear naturally when the temperature of the camera becomes close to the ambient temperature.

❖ Be Sure to Perform Trial Recording in Advance

Perform trial recording in advance of an important event (wedding, etc.) to check that recording can be performed normally.

❖ No Compensation Regarding Recording

Please note that compensation cannot be provided in the event that recording could not be performed due to a problem with the camera or a card.

❖ Be Careful with Regard to Copyrights

Under copyright law, you may not use the images and audio you have recorded for other than personal enjoyment without the permission of the copyright holder. Be careful because there are cases where restrictions apply to recording even for the purpose of personal enjoyment.

❖ Also Refer to the Cautions for Use in the “Operating Instructions <Complete Guide>”

Standard Accessories

Digital camera body

(This is referred to as **camera** in this document.)



Check that all the accessories are supplied before using the camera. (Product numbers correct as of May 2021.)

Battery pack

(This is referred to as **battery pack** or **battery** in this document.)

- Charge the battery before use.

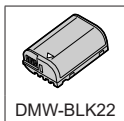

DMW-BLK22

Battery charger

(This is referred to as **battery charger** or **charger** in this document.)

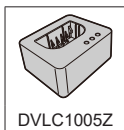

DVLC1005Z

AC adaptor

- This is used for charging and power supply.

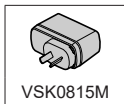

VSK0815M

USB connection cable



K1HY24YY0026

Cable holder

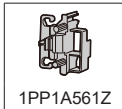

1PP1A561Z

Shoulder strap



DVPW1029Z

Body Cap*¹



VKF4971

Eye Cup*¹



1YE1MC501Z

Hot shoe cover*¹



VYF3522

Cover for the battery grip connector*¹



SKF0145K

Flash synchro socket cap*¹



VKF5108

*¹ This is attached to the camera at the time of purchase.

- **The memory card is optional.**
- Consult the dealer or Panasonic if you lose the supplied accessories. (You can purchase the accessories separately.)
- Please dispose of all packaging appropriately.
- Keep small parts in a safe place out of the reach of children.

Names of Parts

Camera

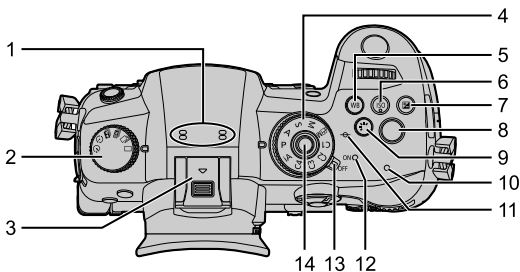

1	Stereo microphone <ul style="list-style-type: none"> Do not block the microphone with a finger. Audio will be difficult to record. 	7	[±] (Exposure compensation) button
2	Drive mode dial	8	Video rec. button
3	Hot shoe (hot shoe cover) <ul style="list-style-type: none"> Keep the hot shoe cover out of reach of children to prevent swallowing. 	9	[•••] (Photo style) button
4	Mode dial	10	Charging light / NETWORK connection lamp
5	[WB] (White balance) button	11	[⊖] (Recording distance reference mark)
6	[ISO] (ISO sensitivity) button	12	Status indicator
		13	Camera on/off switch
		14	Mode dial lock button

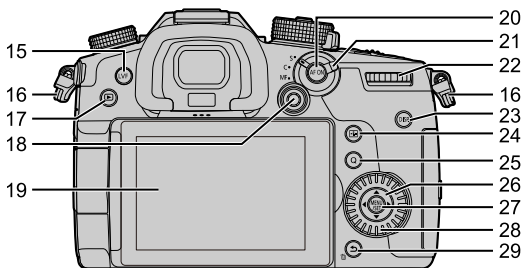

15	[LVF] button
16	Shoulder strap eyelet
17	[▶] (Playback) button
18	Joystick / Fn buttons Center: Fn8, ▲ : Fn9, ► : Fn10, ▼ : Fn11, ◀ : Fn12
19	Monitor / Touch screen
20	[AF ON] button
21	Focus mode lever
22	Rear dial

23	[DISP.] button
24	[AF-ON] (AF mode) button
25	[Q] (Quick menu) button
26	Cursor buttons / Fn buttons ▲ : Fn13, ► : Fn14, ▼ : Fn15, ◀ : Fn16
27	[MENU/SET] button
28	Control dial
29	[↵] (Cancel) button / [⌫] (Delete) button / Fn button (Fn1)

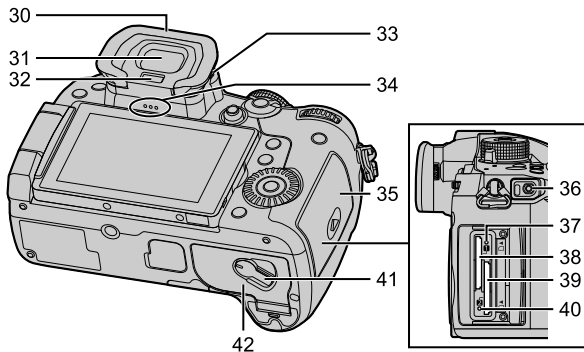

30	Eye cup • Keep the eye cup out of reach of children to prevent swallowing.
31	Viewfinder
32	Eye sensor
33	Diopter adjustment dial
34	Speaker
35	Card door

36	[REMOTE] socket
37	Card access light 1
38	Card slot 1
39	Card slot 2
40	Card access light 2
41	Battery door release lever
42	Battery door

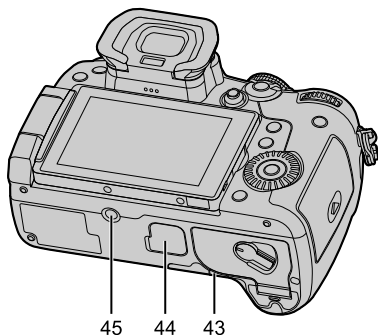

43 DC Coupler cover

- When using an AC adaptor, ensure that the Panasonic DC Coupler (DMW-DCC17: optional) and AC Adaptor (DMW-AC10G: optional) are used.
- Always use a genuine Panasonic AC Adaptor (DMW-AC10G: optional).
- When using an AC Adaptor (optional), use the AC cable supplied with the AC Adaptor (optional).

44 Battery grip connector (cover for the battery grip connector)

- Keep the cover for the battery grip connector out of reach of children to prevent swallowing.

45 Tripod mount

- If you attempt to attach a tripod with a screw length of 5.5 mm (0.22 inch) or more, you may not be able to securely fix it in place or it may damage the camera.

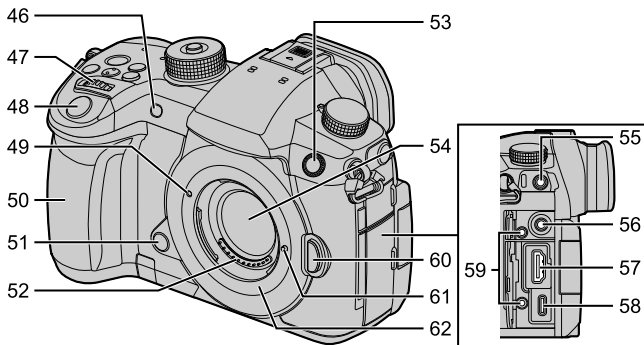

46	Self-timer light / AF assist light
47	Front dial
48	Shutter button
49	Lens fitting mark
50	Grip
51	Preview button / Fn button (Fn2)
52	Contact points
53	Flash synchro socket (flash synchro socket cap) <ul style="list-style-type: none"> Use an external flash with a synchronization voltage of 400 V or less. Keep the flash synchro socket cap out of reach of children to prevent swallowing.

54	Sensor
55	[MIC] socket
56	Headphone socket <ul style="list-style-type: none"> Excessive sound pressure from earphones and headphones can cause hearing loss.
57	[HDMI] socket
58	USB port
59	Cable holder mount <ul style="list-style-type: none"> Keep the clamp portion of the cable holder out of reach of children to prevent swallowing.
60	Lens release button
61	Lens lock pin
62	Mount

Viewfinder / Monitor Displays

At the time of purchase, the viewfinder/monitor displays the following icons.

- For information about the icons other than those described here, refer to "Operating Instructions <Complete Guide>".

Viewfinder

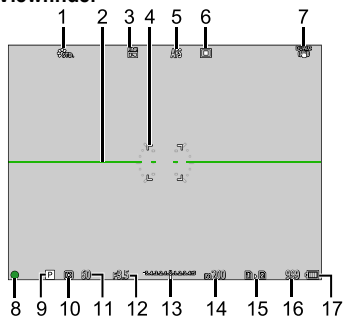

Monitor

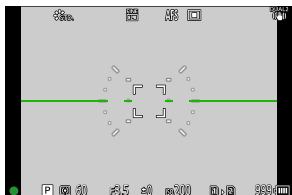

1	Photo Style
2	Level gauge
3	Picture quality / Picture size
4	AF area
5	Focus mode
6	AF mode
7	Image stabilizer
8	Focus (green) / Recording state (red)
9	Recording mode
10	Metering mode

11	Shutter speed
12	Aperture value
13	Exposure compensation value / Manual Exposure Assist
14	ISO sensitivity
15	Card slot / Double card slot function
16	Number of still images that can be taken /
	Number of pictures that can be taken continuously
17	Battery indication

- Press [↵] to switch between display/hide of the level gauge.

Getting Started / Basic Operations

- When preparing, make sure the camera on/off switch is [OFF].



Attaching a Shoulder Strap

Attach a shoulder strap to the camera with the following procedure to prevent it from dropping.

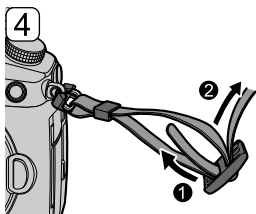
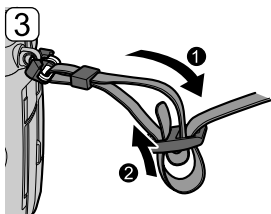
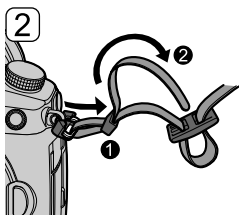
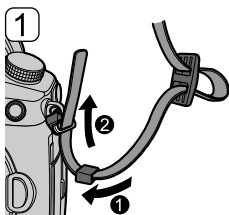

- Pull the shoulder strap and check that it will not come out.
- Attach the opposite end of the shoulder strap with the same procedure.
- Use the shoulder strap around your shoulder.
 - Do not wrap the strap around your neck. It may result in injury or accident.
- Do not leave the shoulder strap where an infant can reach it.
 - It may result in an accident by mistakenly wrapping around the neck.

Charging the Battery

You can charge the battery either using the supplied charger, or in the camera body.

You can also use the battery charger (DMW-BTC15: optional).

- The battery that can be used with the camera is DMW-BLK22 / DMW-BLF19E. (As of May 2021)
 - You can also use DMW-BLF19E (optional), but since it has a smaller battery capacity than DMW-BLK22 (supplied/optional), it is recommended to use DMW-BLK22 (supplied/optional).

- The battery is not charged at the time of purchase. Charge the battery before use.
- **For charging, use this camera or the battery charger (DMW-BTC15: optional) and the items supplied with them.**
- Do not use any other USB connection cables except the one supplied with the camera or the battery charger (DMW-BTC15: optional).
- Do not use any other AC adaptors except the one supplied with the camera or the battery charger (DMW-BTC15: optional).

❖ Charging with the Charger

Charging time	Approx. 230 min
----------------------	-----------------

- Use the supplied charger and AC adaptor.

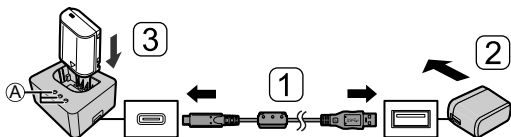

1 Connect the charger and the AC adaptor with the USB connection cable.

- Check the direction of the terminals and plug in/out straight holding onto the plug.
(Inserting these at an angle may cause deformation or malfunction)

2 Connect the AC adaptor to an electrical outlet.

3 Insert the battery.

- The charging lights ([CHARGE]) (A) blink and charging begins.

[CHARGE] Light Indications

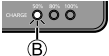
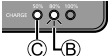
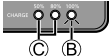
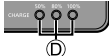
Charging status	0 % to 49 %	50 % to 79 %	80 % to 99 %	100 %
[CHARGE] light				

(B) Blinking

(C) On

(D) Off

- If the [50%] light is blinking quickly, then charging is not occurring.
- When the battery is inserted while the charger is not connected to the power source, the charging lights turn on for a certain period to allow you to confirm the battery level.

❖ Battery Insertion

- Always use genuine Panasonic batteries (DMW-BLK22 / DMW-BLF19E).
– DMW-BLF19E (optional) has a smaller battery capacity than DMW-BLK22.
- If you use other batteries, we cannot guarantee the quality of this product.

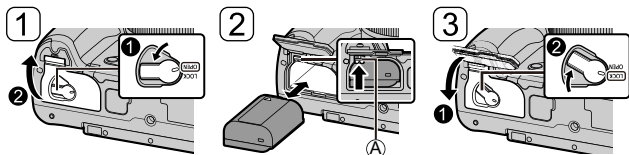

- Check that the lever (A) is holding the battery in place.
- When removing the battery, push the lever (A) toward the arrow and pull out the battery.

❖ Inserting a Battery into the Camera for Charging

Charging time	Approx. 220 min
----------------------	-----------------

- Using the camera body and the supplied AC adaptor.
- The battery in the Battery Grip (DMW-BGGH5: optional) cannot be charged.

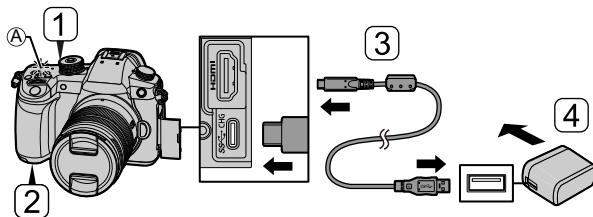

- 1** Set the camera on/off switch to [OFF].
- 2** Insert the battery into the camera.
- 3** Connect the camera USB port and the AC adaptor using the USB connection cable.
 - Check the direction of the terminals and plug in/out straight holding onto the plug.
(Inserting these at an angle may cause deformation or malfunction)
- 4** Connect the AC adaptor to an electrical outlet.
 - The charging light (A) turns red and charging begins.

Charging Light Indications

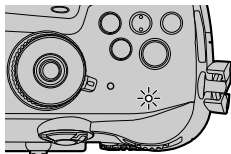

Charging light (red)

On: Charging.

Off: Charging has completed.

Blinking: Charging error.





- Even when the camera on/off switch is set to [OFF] thus turning the camera off, it consumes power.
When the camera will not be used for a long time, remove the power plug from the electrical outlet in order to save power.

❖ Power Supply

When the battery is inserted into the camera for charging and the camera is turned on, you can record while the camera is being supplied with power.

- [] is displayed in the screen while power is being supplied.
- Refer to "Operating Instructions <Complete Guide>" for details about supplying power and charging the battery while power is being supplied.
- Turn off the camera before connecting or disconnecting the AC adaptor.

❖ Battery Indication Display

Battery indication	75 % or higher	50 % to 74 %	25 % to 49 %	24 % or below	Low battery
Indication on monitor					 Blinking in red

- You can use the sleep function to reduce battery consumption.

 → [] → [] → Select [Power Save Mode]

Inserting Cards (Optional)

❖ Memory Cards That Can Be Used (As of May 2021)

You can use the following memory cards with this camera.

**SD memory card / SDHC memory card / SDXC memory card
(Maximum 256 GB)**

- SD memory card, SDHC memory card, and SDXC memory card are referred to by the generic name of **card** in this document.
- This camera supports cards compliant with UHS Speed Class 3 of the UHS-I/UHS-II standard and Video Speed Class 90 of the UHS-II standard.



- When recording **video of 72 Mbps or less**, use cards compatible with SD Speed Class 10, UHS Speed Class 1 or higher, or Video Speed Class 10 or higher.
- When recording **100 Mbps to 200 Mbps video, [6K/4K PHOTO], or [Post-Focus]**, use cards compatible with UHS Speed Class 3 or Video Speed Class 30 or higher.
- When recording **400 Mbps video**, use cards compatible with Video Speed Class 60 or higher.

- **For the latest information on memory cards with confirmed operation, check the following support site:**

<https://panasonic.jp/support/global/cs/dsc/>

(English only)

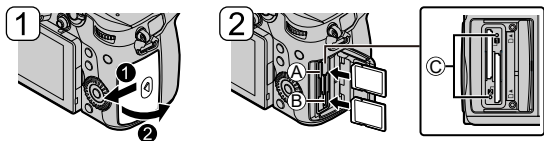

(A) Card slot 1

(B) Card slot 2

- Match the orientation of the cards as shown in the figure and then insert them firmly until they click.
- To remove the card, push the card until it clicks, then pull the card out straight.
- Do not turn off the camera or remove the battery or card until the card access light (C) turns off.

- Format the cards with the camera before use.

→ → → Select [Card Format]

- Keep the memory card out of reach of children to prevent swallowing.

Attaching a Lens

❖ Lenses That Can Be Used

This unit can use the dedicated lenses compatible with the Micro Four Thirds™ System lens mount specification (Micro Four Thirds mount).



You can also use the Leica M Mount interchangeable lens by attaching the M Mount Adaptor (DMW-MA2M: optional).

- Refer to catalogs/websites for most current information regarding supported lenses.

<https://panasonic.jp/support/global/cs/dsc/>
(English only)

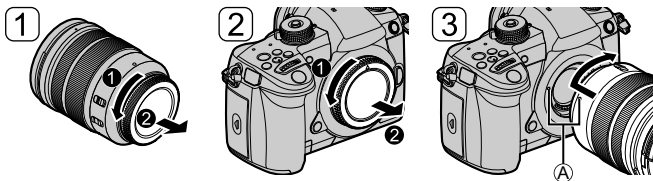

Ⓐ Lens fitting marks

❖ Removing a Lens

- While pressing the lens release button Ⓑ, rotate the lens in the direction of the arrow until it stops and then remove it.

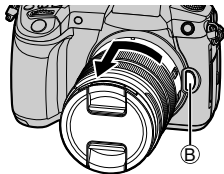

- After removing the lens, be sure to attach the body cap and the lens rear cap.

Adjusting the Monitor Direction and Angle

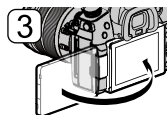
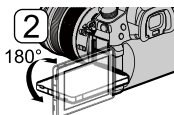
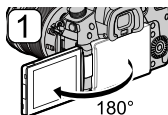

Setting the Clock (When Turning On for the First Time)

When you turn the camera on for the first time, a screen to set the time zone and clock appears. Follow the message to make the settings.

1

2

- Press ▲▼ to select the language if a language selection screen is displayed.

GMT + 9:00 Set



Style Set

<p>Time zone selection</p>	<p>Year, month, day, hour, minute, and second selection</p>
<p>Daylight Savings setting</p>	<p>Value selection</p>

Check or confirm and move to the next screen

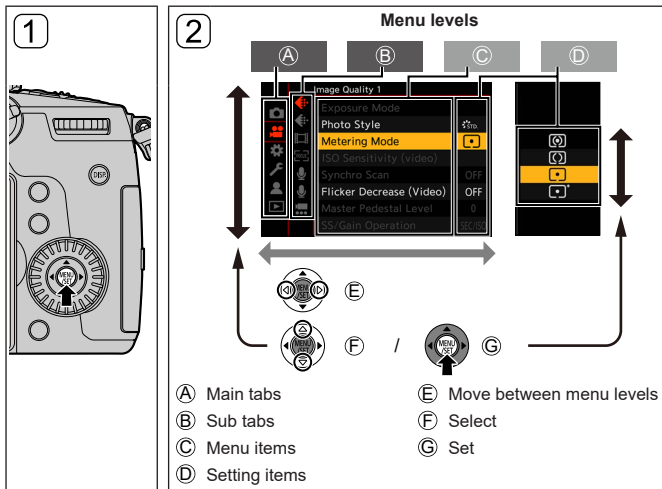
Menu Operation Methods



- If you press [DISP.] while a menu item or setting item is selected, a description about the item is displayed on the screen.
- Menu items that cannot be set are displayed grayed out.
 If you press  or  while a grayed out menu item is selected, the reason why it cannot be set is displayed. (The reason why a menu item cannot be set may not be displayed depending on the menu item.)
- Press the shutter button halfway to close.
- The menu settings can be returned to the default settings.

 →  →  → Select [Reset]

- Refer to the “Operating Instructions <Complete Guide>” for details about menu items.
- Refer to the “Operating Instructions <Complete Guide>” for a list of default settings and reset targets.

Materials

Message Displays

Meanings of main messages displayed on the camera screen, and response methods.

- Please also refer to the “Operating Instructions <Complete Guide>”, which describes more detailed information.

[Memory Card Error] / [Format this card?]

- It is a format that cannot be used with the camera.
Either insert another card, or back up any necessary data before formatting.
(→25)

[Memory Card Error] / [This memory card cannot be used]

- Use a card compatible with the camera. (→25)

[Read Error] / [Write Error] / [Please check the card]

- Failure to read or write data.
Turn off the camera, reinsert the card, and then turn it on again.
- The card may be broken.
- Insert a different card.

[The lens is not attached properly. Do not push lens release button while lens is attached.]

- Remove the lens once, and then attach it again without pressing the lens release button. (→27)
Turn on the camera again, and if it is still displaying, contact the dealer.

[This battery cannot be used]

- Use a genuine Panasonic battery.
If this message is displayed even when a genuine Panasonic battery is used, contact the dealer.
- If the terminal of the battery is dirty, remove the dirt and dust from the terminal.

[Please turn camera off and then on again] / [System Error]

- Turn off and on the camera.
If the message is displayed even when doing this several times, contact the dealer.

Troubleshooting

First, try out the following procedures (→31 to 32).

If the problem is not resolved, it may be improved by selecting [Reset] on the [Setup] ([Setting]) menu.

- Please also refer to the “Operating Instructions <Complete Guide>”, which describes more detailed information.

The battery becomes flat too quickly.

- When [6K/4K Pre-Burst] or [Pre-Burst Recording] is set, the battery drains faster. Set these settings only when recording.
- When connected to Wi-Fi, the battery drains quickly. Turn the camera off frequently such as by using [Power Save Mode].

Recording stops before finishing.

Cannot record.

Cannot use some functions.

- In high ambient temperatures or if the camera is continuously used for High-definition video recording, high-speed burst pictures, and HDMI output etc., the temperature of the camera will rise. If the camera temperature rises,  will be displayed blinking on the screen. If you continue to use the camera, a message indicating the camera cannot be used is displayed on the screen and recording or HDMI output stops. Wait until the camera cools down.

The recorded image looks rough.

Noise appears on the picture.

- When using the camera continuously, the temperature inside of the camera rises and the image quality may deteriorate. Turning the camera off except when recording is recommended.

The subject is not focused properly.

- Confirm the following details:
 - Is the subject outside of the focus range?
 - Is [Shutter AF] set to [OFF]?
 - Is [Focus/Shutter Priority] set to [RELEASE]?
 - Is AF Lock set where it is not appropriate?

Striping or flicker may appear under lighting such as fluorescent or LED lighting.

- This is characteristic of MOS sensors which serve as the camera's pickup sensors. This is not a malfunction.
- When using the electronic shutter, lowering the shutter speed may reduce the effect of the horizontal stripes.
- If flicker or horizontal stripes are noticeable when recording video, this can be mitigated by fixing the shutter speed.
Either set [Flicker Decrease (Video)], or fix the shutter speed with the [M] mode.

The brightness or coloring of the recorded image is different from the actual scene.

- When recording under lighting such as fluorescent or LED lighting, increasing the shutter speed may introduce slight changes to brightness or coloring. These are a result of the characteristics of the light source and do not indicate a malfunction.
- When recording subjects in extremely bright locations or recording under lighting such as fluorescent, LED, mercury, or sodium lighting, the coloring or screen brightness may change or horizontal striping may appear on the screen.

The flash does not fire.

- The flash does not fire when using the following functions:
 - Video recording/[6K/4K PHOTO]/[Post-Focus]
 - [ELEC.]/[Silent Mode]
 - [Filter Settings]

When the camera is shaken, a rattling sound is heard from the camera.

- The sound is caused by the in-body stabilizer. This is not a malfunction.

There is rattling noise from the lens when the camera is turned on or off, or when the camera is swung.

There is a sound from the lens when recording.

- This is the sound of the lens moving and aperture operation. It is not a malfunction.

Specifications

- Please also refer to the “Operating Instructions <Complete Guide>”, which lists more items.

The specifications are subject to change for performance enhancement.

Digital camera body (DC-GH5M2):

Information for your safety

Power source:	9.0 V ===
Power consumption:	4.5 W (when recording with the monitor), 3.8 W (when playing back with the monitor) [When using the interchangeable lens (H-ES12060)]

Type

Type	Digital Single Lens Mirrorless camera
Recording media	SD memory card / SDHC memory card / SDXC memory card
Lens mount	Micro Four Thirds Mount

Image sensor

Image sensor	4/3" Live MOS sensor, total pixel number 21,770,000 pixels, Primary color filter
Effective number of pixels of the camera	20,330,000 pixels

Recording format for still images	
File format for still images	JPEG (DCF compliant, Exif 2.31 compliant) / RAW
Picture size (pixels)	When the aspect ratio setting is [4:3] [L]: 5184×3888 [M]: 3712×2784 [S]: 2624×1968 6K photo: 4992×3744 4K photo: 3328×2496
Recording format for video	
Video format	MP4 (H.264/MPEG-4 AVC, H.265/HEVC) MOV (H.264/MPEG-4 AVC, H.265/HEVC)
Audio format	MP4 AAC (2ch)
	MOV LPCM (2ch, 48 kHz/16-bit)*1 *1 When an XLR Microphone Adaptor (DMW-XLR1: optional) is attached, LPCM (2ch, 48 kHz/24-bit, 96 kHz/24-bit) can be selected
System frequency	59.94 Hz / 50.00 Hz / 24.00 Hz
Image quality for video	Refer to “Operating Instructions <Complete Guide>” for information about resolution, recording frame rate, and other elements of recording quality.
Viewfinder	
System	Aspect ratio 4:3, 0.5 inches, approx. 3,680,000 dots, organic EL (OLED) live view viewfinder
Field of view ratio	Approx. 100 %
Magnification	Approx. 0.76x (35 mm film camera equivalent) (−1.0 m ⁻¹ 50 mm at infinity, with aspect ratio set to [4:3])

Monitor	
System	Aspect ratio 3:2, 3.0 inches, approx. 1,840,000 dots monitor, capacitive touch screen
Field of view ratio	Approx. 100 %
Focus	
AF type	TTL type based on image detection (Contrast AF)
Exposure control	
Light metering system, Light metering mode	1728-zone metering, multi-metering / center-weighted metering / spot metering / highlight-weighted metering
Metering range	EV 0 to EV 18 (F2.0 lens, ISO100 conversion)
ISO sensitivity (standard output sensitivity)	AUTO / 200 to 25600, When [Extended ISO] is set: AUTO / 100 to 25600, 1/3 EV steps
Shutter	
Format	Focal-plane shutter
Shutter speed	<p>Pictures:</p> <p>Mechanical shutter: Bulb (max. approx. 30 minutes), 60 seconds to 1/8000 of a second</p> <p>Electronic front curtain: Bulb (max. approx. 30 minutes), 60 seconds to 1/2000 of a second</p> <p>Electronic shutter: Bulb (max. approx. 60 seconds), 60 seconds to 1/16000 of a second</p> <p>Videos:</p> <p>1/25*2 of a second to 1/16000 of a second</p> <p>*2 When [Exposure Mode] is set to [M] in [⊞M] and focus mode is set to [MF], this can be set up to 1/2</p>
Flash synchronization speed	Equal to or smaller than 1/250 of a second

Zoom	
Extended Tele Conversion (Picture)	Max. 2.0x (when a picture size of [S] is selected.)
Interface	
USB	USB Type-C™, SuperSpeed USB3.1 GEN1, Supports USB Power Delivery (9.0 V/3.0 A)
[HDMI]	HDMI Type A
[REMOTE]	Ø2.5 mm jack
[MIC]	Ø3.5 mm stereo mini jack
Headphones	Ø3.5 mm stereo mini jack
Flash Synchro	Yes
Splash Resistant	
Yes	
External dimensions / Mass	
External dimensions	Approx. 138.5 mm (W)×98.1 mm (H)×87.4 mm (D) (5.45" (W)×3.86" (H)×3.44" (D)) (excluding the projecting parts)
Mass (Weight)	Approx. 727 g / 1.60 lb (camera body, with battery and one card) Approx. 647 g / 1.43 lb (only camera body)
Operating environment	
Recommended operating temperature	-10 °C to 40 °C (14 °F to 104 °F) • Battery performance temporarily worsens at low temperatures (-10 °C to 0 °C (14 °F to 32 °F)), reducing the number of pictures that can be taken and the available recording time.
Permissible relative humidity	10 %RH to 80 %RH

Wi-Fi	
Compliance standard	IEEE 802.11a/b/g/n/ac (standard wireless LAN protocol)
Frequency range used (central frequency)	2412 MHz to 2472 MHz (1 to 13ch) 5180 MHz to 5320 MHz (36/40/44/48/52/56/60/64ch) 5500 MHz to 5700 MHz (100/104/108/112/116/132/136/140ch) 5745 MHz to 5825 MHz (149/153/157/161/165ch)
Encryption method	Wi-Fi compliant WPA™ / WPA2™
Access method	Infrastructure mode
Bluetooth	
Compliance standard	Bluetooth v4.2, Bluetooth Low Energy (BLE)
Frequency range used (central frequency)	2402 MHz to 2480 MHz

Battery charger (Panasonic DVLC1005Z):

Information for your safety

Input:	9.0 V --- 3.0 A	5.0 V --- 1.8 A
Output:	8.4 V --- 1.2 A	8.4 V --- 0.85 A
Operating temperature:	0 °C to 40 °C (32 °F to 104 °F)	

AC adaptor (Panasonic VSK0815M):

Information for your safety

Input:	110 V–240 V \sim 50/60 Hz 0.25 A
Output:	5.0 V --- 1.8 A
Operating temperature:	0 °C to 40 °C (32 °F to 104 °F)

Battery pack (lithium-ion) (Panasonic DMW-BLK22):

Information for your safety

Voltage/capacity:	7.2 V / 2200 mAh
--------------------------	------------------

The symbols on this product (including the accessories) represent the following:

\sim	AC
---	DC
	Class II equipment (The construction of the product is double-insulated.)

A series of horizontal lines for writing.

Trademarks and Licenses



- Micro Four Thirds™ and Micro Four Thirds Logo marks are trademarks or registered trademarks of OM Digital Solutions Corporation, in Japan, the United States, the European Union and other countries.
- SDXC Logo is a trademark of SD-3C, LLC.
- The terms HDMI and HDMI High-Definition Multimedia Interface, and the HDMI Logo are trademarks or registered trademarks of HDMI Licensing Administrator, Inc. in the United States and other countries.
- USB Type-C™ and USB-C™ are trademarks of USB Implementers Forum.
- The USB Type-C™ Charging Trident Logos are trademarks of USB Implementers Forum, Inc.
- The SuperSpeed USB Trident Logo is a registered trademark of USB Implementers Forum, Inc.
- QuickTime and the QuickTime logo are trademarks or registered trademarks of Apple Inc., used under license therefrom.
- HDAVI Control™ is a trademark of Panasonic Corporation.
- Adobe is a trademark or registered trademark of Adobe Systems Incorporated in the United States and/or other countries.



- The Bluetooth® word mark and logos are registered trademarks owned by Bluetooth SIG, Inc. and any use of such marks by Panasonic Corporation is under license. Other trademarks and trade names are those of their respective owners.
- The Wi-Fi CERTIFIED™ Logo is a registered trademark of Wi-Fi Alliance®.
- The Wi-Fi Protected Setup™ Logo is a trademark of Wi-Fi Alliance®.
- "Wi-Fi®" is a registered trademark of Wi-Fi Alliance®.
- "Wi-Fi Protected Setup™", "WPA™", and "WPA2™" are trademarks of Wi-Fi Alliance®.
- This product uses "DynaFont" from DynaComware Corporation. DynaFont is a registered trademark of DynaComware Taiwan Inc.
- QR Code is a registered trademark of DENSO WAVE INCORPORATED.
- Other names, company names, product names mentioned in this document are trademarks or registered trademarks of the companies concerned.

This product incorporates the following software:

- (1) the software developed independently by or for Panasonic Corporation,
- (2) the software owned by third party and licensed to Panasonic Corporation,
- (3) the software licensed under the GNU General Public License, Version 2.0 (GPL V2.0),
- (4) the software licensed under the GNU LESSER General Public License, Version 2.1 (LGPL V2.1), and/or
- (5) open source software other than the software licensed under the GPL V2.0 and/or LGPL V2.1.

The software categorized as (3) - (5) are distributed in the hope that it will be useful, but WITHOUT ANY WARRANTY, without even the implied warranty of MERCHANTABILITY or FITNESS FOR A PARTICULAR PURPOSE. Please refer to the detailed terms and conditions thereof displayed by selecting [MENU/SET] → [Setup] → [Others] → [Firmware Version] → [Software info].

At least three (3) years from delivery of this product, Panasonic will give to any third party who contacts us at the contact information provided below, for a charge no more than our cost of physically performing source code distribution, a complete machine-readable copy of the corresponding source code covered under GPL V2.0 or LGPL V2.1, as well as the respective copyright notice thereof.

Contact Information: oss-cd-request@gg.jp.panasonic.com

The source code and the copyright notice are also available for free in our website below.

<https://panasonic.net/cns/oss/index.html>

This product is licensed under the AVC Patent Portfolio License for the personal use of a consumer or other uses in which it does not receive remuneration to (i) encode video in compliance with the AVC Standard ("AVC Video") and/or (ii) decode AVC Video that was encoded by a consumer engaged in a personal activity and/or was obtained from a video provider licensed to provide AVC Video. No license is granted or shall be implied for any other use. Additional information may be obtained from MPEG LA, L.L.C.

See <http://www.mpegla.com>

Panasonic Warranty

1. Subject to the conditions of this warranty Panasonic or its Authorised Service Centre will perform necessary service on the product, without charge for parts or labour, if in the opinion of Panasonic the product is found to have a manufacturing defect within one (1) year or (12 months) (the "warranty period") from the date of purchase appearing on your purchase receipt.
2. This warranty only applies to Panasonic products purchased in Australia and sold by Panasonic Australia, its Authorised Distributors, or Dealers, and only where the products are used and serviced within Australia or its territories. Warranty cover only applies to the services that are carried out by a Panasonic Authorised Service Centre and only if valid proof of purchase is presented when the warranty service is requested.
3. This warranty only applies if the product has been installed and/or used in accordance with the manufacturer's recommendations (as noted in the operating instructions) under normal use and reasonable care (in the opinion of Panasonic). The warranty does not cover damage, malfunction or failure resulting from use of incorrect voltages, incorrect installation, accident, misuse, neglect, build-up of dirt or dust, abuse, maladjustment of customer controls, mains supply problems, thunderstorm activity, infestation by insects or vermin, tampering or repair by unauthorised persons (including unauthorised alterations), exposure to abnormally corrosive conditions, or any foreign object or matter having entered the product.
4. This warranty does not cover the following items unless the fault or defect existed at the time of purchase:
 - (a) Consumable parts
 - (b) Cosmetic parts
 - (c) Worn or damaged parts
 - (d) Information stored on Hard Disk Drives, Optical Discs, USB Devices, SD Cards, Tapes
 - (e) DTV reception issues caused by TV Aerial / Cabling / Wall socket(s)
5. Some products may be supplied with Ethernet connection hardware. The warranty is limited on such products and will not cover:
 - (a) Internet and or DLNA connection / setup related problems
 - (b) Access fees and or charges incurred for internet connection
 - (c) Incompatible software or software not specifically stipulated in the product operations manual; and
 - (d) Any indirect or consequential costs associated with the incorrect use or misuse of the hardware, its connection to the internet or any other device.
6. To claim warranty service, when required, you should:
 - Contact Panasonic's Customer Care Centre on 132 600 for Service Centre information.
 - Confirm the opening and acceptance times with the Authorised Service centre that you choose.
 - Then send or take the product to a Panasonic Authorised Service Centre together with your proof of purchase receipt.
 - Any freight and insurance costs associated with the transport of the product to and/or from your nearest Authorised Service Centre must be arranged and paid for by you.

7. The warranties hereby conferred do not extend to, and exclude, any costs associated with the installation, de-installation or re-installation of a product, including costs related to the mounting, de-mounting or remounting of any screen, (and any other ancillary activities), delivery, handling, freighting, transportation or insurance of the product or any part thereof or replacement of and do not extend to, and exclude, any damage or loss occurring by reason of, during, associated with, or related to such installation, de-installation, re-installation or transit.

Panasonic Authorised Service Centres are located in major metropolitan areas and most regional centres of Australia, however, coverage will vary dependant on product. For advice on exact Authorised Service Centre locations for your product, please telephone our Customer Care Centre on 132600 or visit our website and use the Service Centre Locator.

In addition to your rights under this warranty, Panasonic products come with consumer guarantees that cannot be excluded under the Australian Consumer Law. If there is a major failure with the product, you can reject the product and elect to have a refund or to have the product replaced or if you wish you may elect to keep the goods and be compensated for the drop in value of the goods. You are also entitled to have the product repaired or replaced if the product fails to be of acceptable quality and the failure does not amount to a major failure.

If there is a major failure in regard to the product which cannot be remedied then you must notify us within a reasonable period by contacting the Panasonic Customer Care Centre. If the failure in the product is not a major failure then Panasonic may choose to repair or replace the product and will do so in a reasonable period of time from receiving notice from you.

THIS WARRANTY CARD AND THE PURCHASE DOCKET (OR SIMILAR PROOF OF PURCHASE) SHOULD BE RETAINED BY THE CUSTOMER AT ALL TIMES

If you require assistance regarding warranty conditions or any other enquiries, please visit the Panasonic Australia website www.panasonic.com.au or contact by phone on **132 600**
If phoning in, please ensure you have your operating instructions available.

Panasonic Australia Pty. Limited

ACN 001 592 187 ABN 83 001 592 187
1 Innovation Road, Macquarie Park NSW 2113
www.panasonic.com.au

PRO-031-F11 Issue: 5.0

23-01-2018

Panasonic Corporation
Web Site: <http://www.panasonic.com>

© Panasonic Corporation 2021