

Ventilating Fan Specifications

Model FV-20CUT1

		110V		120V		220V		230V		240V
		50Hz	60Hz	50Hz	60Hz	50Hz	60Hz	50Hz	60Hz	50Hz
Air Volume	CMH \pm 10%	438	444	450	468	438	456	444	468	450
Power Consumption	W \pm 15%	16.3	18.7	18.7	21.8	22.6	23.9	23.9	25.5	25.7
Current	A \pm 15%	0.150	0.170	0.160	0.180	0.110	0.110	0.110	0.110	0.120
Speed	R/M \pm 10%	1155	1181	1215	1289	1153	1245	1186	1297	1207
Noise	dB (A)	40.5	40.8	41.5	42.5	40.5	41.4	40.8	42.5	41.5

1. Power Rating ----- AC 110-120V 50Hz / 110-120V 60Hz
AC 220-240V 50Hz / 220-230V 60Hz
2. Motor Type ----- Capacitor start and run induction motor
3. Blade Type ----- 200mm dia propeller fan
4. Ambient temperature ----- - 10 to 50 deg.C
5. Insulation Resistance ----- More than 1 meg ohm
6. Electric Strength ----- AC 1500V 1 minute
7. Weight ----- 1.8 Kg
8. Dimensions ----- See attached drawing

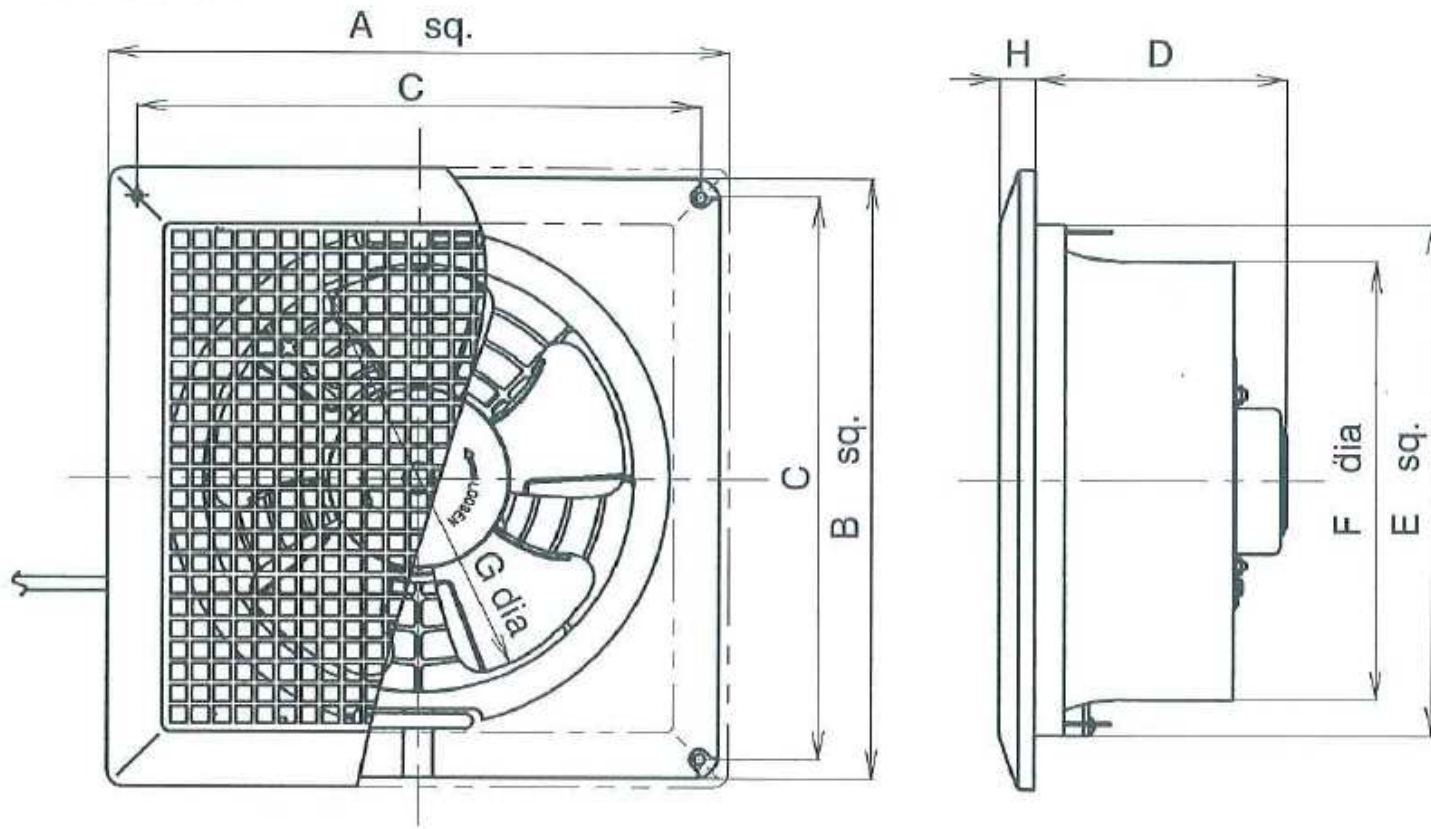

FV-20CUT1	A	B	C	D	E	F	G	H
	315	305	286	128	260	223	200	18