

Panasonic

Connect with your smartphone using this QR.



Product information

Website will be opened in November 2021



Technical documents

Download from PRO CLUB NX series technical document will be available in November 2021.

PACKAGED AIR CONDITIONER 2023/2024

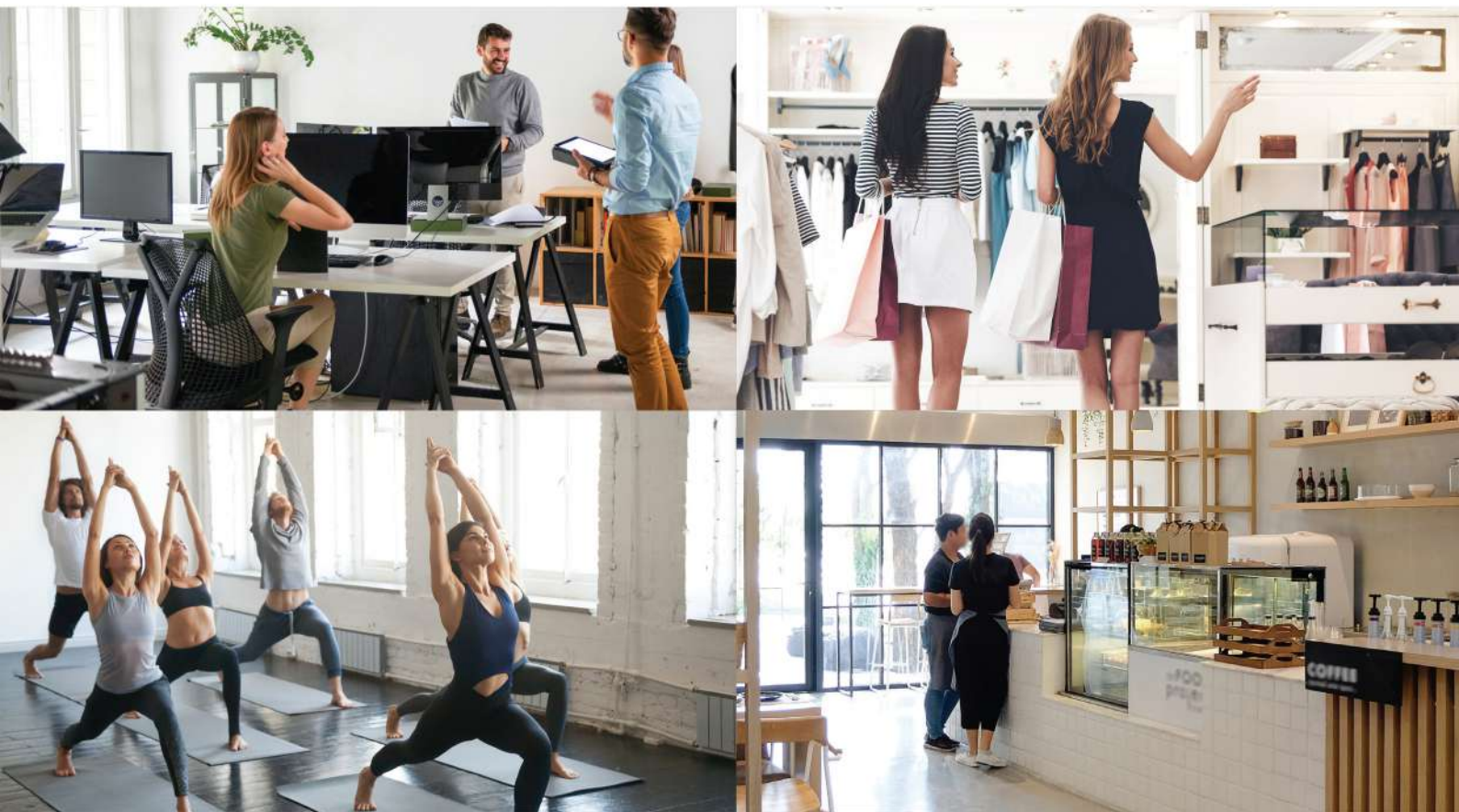

Live Your Best

QUALITY AIR FOR LIFE

Extremely Clean Air and Energy-Saving Efficiency

Panasonic packaged air conditioners offer comfortable room environments. They all* come standard equipped with unique nanoe™ technology that suppresses unpleasant odors and inhibits bacteria and viruses. And they feature a wide lineup of indoor and inverter type outdoor units for use in a variety of locations, such as offices, residences, restaurants, and shops. Panasonic air conditioners provide solutions for comfortable, clean air and energy savings at all times.

*4-Way Cassette Type only.



What's new



New nanoe™ X containing plenty of OH radicals that Inhibits bacteria and virus, deodorizes unpleasant odors and keeps room air clean and fresh.

CONTENTS

FEATURE HIGHLIGHT

Introduction	2-3
4-Way Cassette NEW ///	4-5
nanoe™ TECHNOLOGY	6-7
R32 Outdoor Units NEW ///	8-9
Remote Controller	10-13

NON-INVERTER

Model Line-Up	14-15
Specifications	
4-Way Cassette	16-17
Mini Cassette	18-19
Floor Standing	20-21
4-Way Cassette Fresh series	22-23
Ceiling Ducted Fresh series	24-25
Ceiling Suspended/Console Fresh series	26-27
Outdoor Units	
Dimensions	28-31

INVERTER

Model Line-Up	32-33
Specifications	
4-Way Cassett NEW ///	34-35
Mini Cassette	36-37
Ceiling Suspended NEW ///	38-39
Ceiling Ducted NEW ///	40-41
Outdoor Units	
Dimensions	42-43



4-Way Cassette **R32** **INVERTER** **NEW** ///



4-Way Cassette with R32 refrigerant
Provides environmentally friendly products and more efficient performance.

Flexible Installation



Highly efficient inverter operation achieves superior energy-savings. And all models are 1-Fan types for easier installation and construction.

4-Way Cassette **NEW**



Provides a neat fit in the ceiling to match modern decor, and uniform cooling throughout the room, plus easy installation.



Powerful Airflow

The Twisted 3D Blade Fan with compact design can increase airflow.



Wide Flap

Adding a sub flap and widening the main flap have reduced turbulence and increased airflow. Also, the wider angle jetting port allows the airflow to reach as far as five meters.

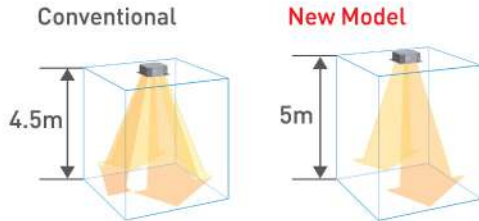

Conventional

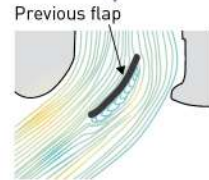
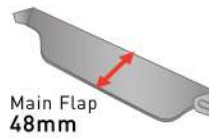

As airflow turbulence is generated, airflow velocity gets lower.

New Model

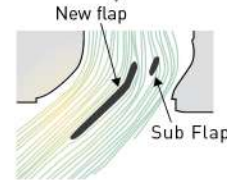
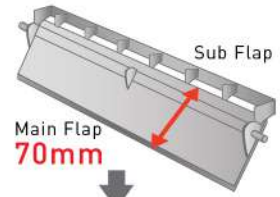

As airflow turbulence is reduced, airflow velocity gets higher.

360° Wide & Comfortable Airflow

Air coming out of the centre of the discharge outlets travels farther. Air is discharged across a wide area from the four sides of the unit. The curves on the room temperature distribution graph expand gently out through 360° in a circle centred on the indoor unit.

Ample airflow: 33 m³/min
Industry's leading in the 4 Way Cassette: 3448PU Type.

360° Wide

Temperature distribution by thermograph (cooling operation)



Simulation conditions:
45PU 4-way ceiling-mounted cassette type in cooling mode/
Floor area of 225 m²/ Ceiling height of 3 m

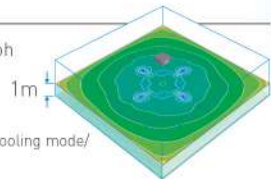

Flat Horizontal Design

Panasonic believes that one of the most important elements of design is that it doesn't interfere with the overall room interior. The flat horizontal design of the 4-way Cassette achieves an elegant, yet simple form. This design allows it to protrude only 33.5 mm from the ceiling, to blend naturally into a variety of interiors, including offices and restaurants.



Installation Instruction

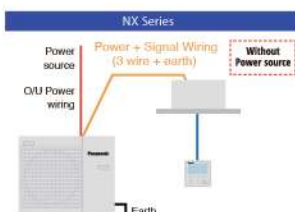

3 Wire Method

This NX series has been developed with 3 wire method and communication.

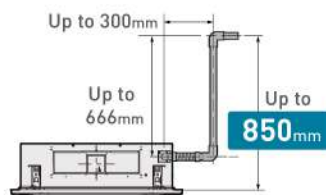

A strong and quiet drain pump

The drain pump can pump water up to a height of 850 mm, making drain pipe layout easy. Supports for 4-way Cassette



NEW // Operation Temperature

New NX series are capable of working even in the most difficult ambient conditions. Operating range expanded up to outdoor air temperature of 46°C.



nanoe™ is Panasonic's unique air purifying technology. Introduced in 2003, nanoe™ has brought comfortable, clean air to a wide variety of living environments. By conducting further research & development, Panasonic has now succeeded in developing nanoe™ X, with dramatically increased performance.

nanoe™ X Creating Cleaner Environments

Panasonic's unique nanoe™ X has an outstanding effect on inhibits 5 types of pollutants, deodorizes, and moisturizes that have by action of hydroxyl radicals contained in water.



7 Effects of nanoe™ X : Creating Cleaner Environments

nanoe™ inhibits 5 types of pollutants, deodorises and moisturises thanks to the action of hydroxyl radicals contained in water.

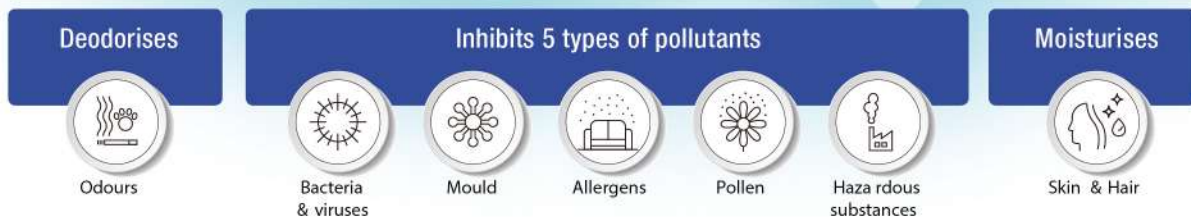

nanoe™ X Effectiveness Proven in Large Space

Access to the evidence page of nanoe™ X effect

nanoe™ X Mechanism

Amount of OH radicals increases without increasing amount of ozone, leading to improved effectiveness!

Generation Mechanism

nanoe™ X is generated from moisture in the air



Structure

OH radical

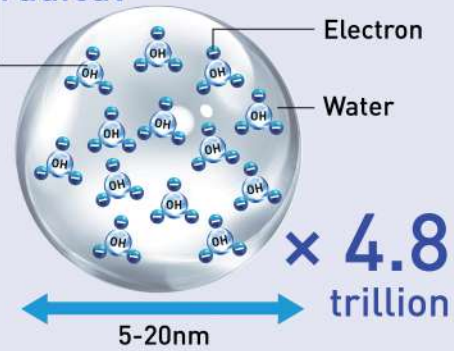

How to Deodorize Odor*^{1 2 3}



How to Inhibit Bacteria, Virus and Mold*^{4 5 6 7 8}



Also Cleans the Air When Not Air Conditioning

You can also use nanoe™ X in Fan mode when you're not cooling or heating the room. For example, you can use nanoe™ X to effectively suppress bacteria and odors without using excessive electricity when the office is empty or after business hours in a restaurant.



AC Mode + nanoe™ X

nanoe™ X purifies the room while maintaining the comfort temperature when people are in presence.

FAN Mode + nanoe™ X

After closing shops and facilities, nanoe™ X can perform air purification while they are not in use.

Case Examples of nanoe™



R32 Outdoor Units **NEW**

INVERTER
R32
REFRIGERANT



More Efficient, Less Space

While maintaining its strong power, higher energy efficiency of R32, coupled with Panasonic's technology, the ingenious design allows for a more compact outdoor unit that fits into any space and layout.

Can be installed in the limited space

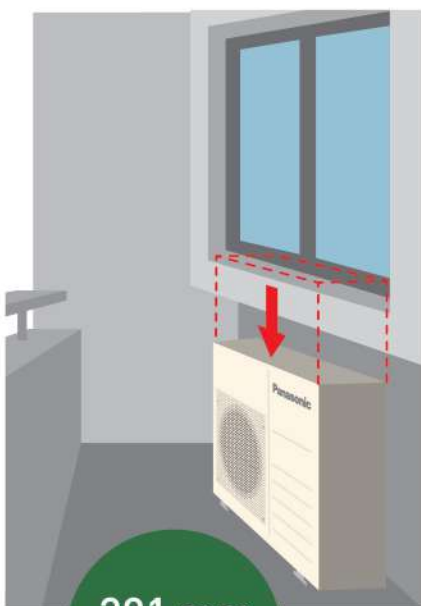

301 mm Shorter

30-36k Btu/h Model

U-30PN1H5 / U-30PN1H8 / U-36PN1H8

19-50k Btu/h Model

U-18PR1H5/U-21PR1H5/U-24PR1H5/
U-30PR1H5/U-34PR1H5/U-43PR1H5/
U-48PR1H5/U-43PR1H8/U-48PR1H8

Conventional Model

U-40PV1H8 H996 × W980 × D370

New Model



Height	996 mm	695 mm*	↓ 301 mm Shorter
Weight	86 kg	56 kg	↑ 38 kg Lighter

*Comparison between U-40PV1H8 and U-48PN1H8.

High Efficiency

R32 refrigerant yields higher energy efficiency than R410A. The Coefficient of Performance (COP) has been greatly improved to reduce power consumption.



Quality

In-house manufactured compressor

Panasonic all in-house manufactured compressors are supplied to the world. The cumulative total of high-quality compressors in use has reached 580 million units*.

*As of September 2019. (In-house research)



High durability outdoor unit

Corrosion-resistance treated for high resistance to rust and salty air to assure long-lasting performance.



Installation

Long piping

The maximum chargeless piping length is 7.5m, but it can be extended up to 50m with additional gas charging for greater installation flexibility.

Piping length

	BTU	19-25k	30-36k	42-50k
Max. Pipe Length		30 m	45 m	50 m
Max. Chargeless Length #		7.5 m	7.5 m	7.5 m
Max. Height Difference		20 m	30 m	30 m

Additional gas is required when pipe length is extended.

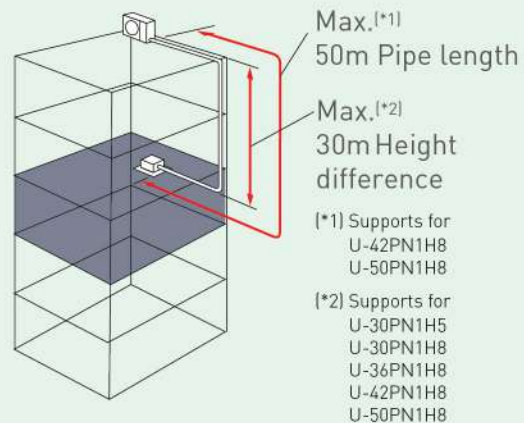

Maintenance

Service maintenance

The PCB inside the outdoor unit has been removed, allowing easy installation and service maintenance.

Supports for
U-19PN1H5
U-25PN1H5
U-30PN1H5

• Single phase only.



Remote Controller

Precise Control, Easy Comfort

Panasonic Packaged Series Remote Controllers are designed with user comfort in mind. Multiple settings are available so airflow and air quality can be regulated according to preferences. Users can also opt for a wired remote controller equipped with high-performance timer.



Wired Remote Controller

CZ-RD513C

[For 4-Way Cassette Type and Ceiling Exposed Type]



*Ceiling Ducted Type remote controller is in the same package.

Wireless Remote Controller / Receiver

4-Way Cassette Type (Optional)

Ceiling Suspended Type (Optional)



CZ-RL013U (Non-Inverter) CZ-RL013UH (Inverter)



CZ-RL013T

Settings can be regulated with 3 control options:

Group Control by a single remote controller

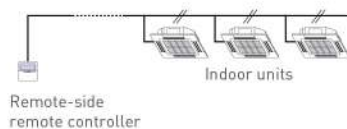

- All indoor units operate in the same mode.

Separate Control by Twin Remote Controllers

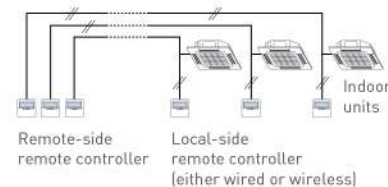

- Each indoor unit can be operated by either of the two remote controllers.
- Apart from the timer setting time, the displays for the two remote controllers are identical.
- The last button pressed has priority (The main or slave attribute is set with the remote controller).

Common Control by Both Wired and Wireless Remote Controllers

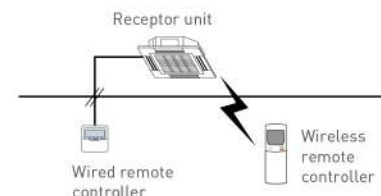

- The last button pressed has priority (using either wired or wireless remote controllers).

Weekly Timer (For All Models)

1. Timer can be set for each day of the week.
2. Can be pre-set with: •Max. 6 settings/day •42 settings/week.
3. The temperature can also be programmed for optimal comfort.

Pre-sets for different conditions

Businesses with regular off days

Example:
Saturday afternoon - CLOSED
Sunday - CLOSED

Mon-Fri	On 9:00, Off 18:00
Sat	On 9:00, Off 12:00
Sun	Not set

▶ Timer settings can be different every day of the week.

Businesses with varying visitor flows at different timings

Example:
Lunchtime - More visitors, lower temperature

Daily Settings	On 12:00 23°C
	On 14:00 28°C

▶ Timing & temperature can be set simultaneously.

Can be set to switch off automatically

Example:
Avoid power wastage even if users forget to turn it off (weekdays)

Mon-Fri	Off 20:00
---------	-----------

▶ Timer can be set for simple shut-off operation.

Setting the timer



*Simple Timer Mode
Using the 24-Hour ON/OFF timer, ON/OFF operations can be set at the same time daily.

Odour Wash

(For All Models)

Reduces unpleasant odours caused by the air conditioner's heat exchanger.

Odour Removing ONE PUSH

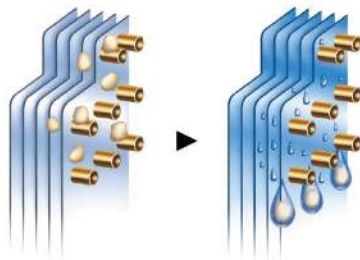

When air from the outlet smells musty, moisture in the heat exchanger washes away odours.

Can be operated with the wireless remote controller.

Economy Mode

(For All Models)

Saves up to 20%* energy. The air conditioner determines the stable condition and moderately shifts the set temperature in 0.5-degree steps to regulate the energy-saving operation (max. 2 degrees).

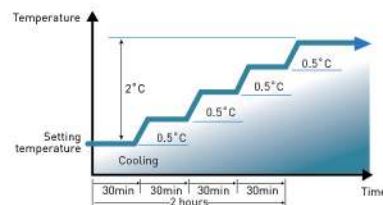

*During operating in the cooling mode at the remote control set temperature of 25 under the cooling standard temperature conditions.

Can be operated with the wireless remote controller.

Ventilation

(For All Models)

When an external device such as a ventilator is connected to the indoor unit, the ventilator's ON/OFF operations can be controlled by the wired remote controller. You can select from either link-ventilation or independent-ventilation.

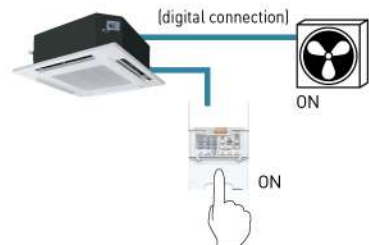

Ventilators are not included in the product line-up. OPTIONAL : Printed circuit board (Interface Adapter for External Signals CZ-TA31P*) is needed.

*Printed Circuit Board CZ-TA31P

- By connecting to the indoor unit, a separately sold ventilator can be controlled.
- Remote operation control of the indoor unit is enabled (ON/OFF control).
- The condition of the indoor unit (malfunctions, operating status) can be output externally.
- Control in linkage to a total heat exchanger or similar devices is possible.

Multi Comfort Air Control (For Cassette Models)

New control technology gives users a wide selection of more specific airflow angles. Choose from the 3-Pattern Auto Swings to avoid direct exposure to cool air (total 50-degree swing width).

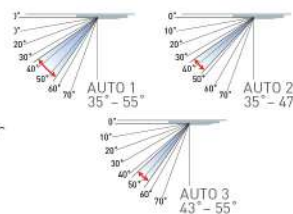

Central Control Adapter

Using Central Control Adapter along with the existing VRF units, a centralized control system is possible. Temperature management can be achieved by expanding low-to-mid sizes together.



CZ-CAPRA1+CZ-CCERA1
H120×W70×D32,5mm

Even buildings with additional air conditioning systems can be central controlled

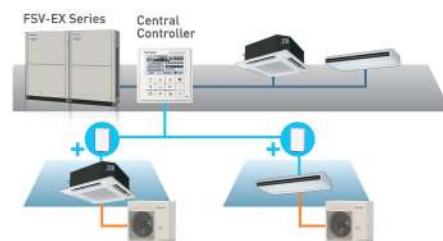

CONEX goes beyond simple remote control to combine sophistication with simplicity, offering IoT integration that connects directly to a variety of apps for next-generation solutions.



Smart Comfort with CONEX

CONEX offers IoT integration that connects directly to a variety of apps for next-generation solutions. Easy control and access for end users, installers, and service partners with just one remote.

New CONEX Control
New smart design with built-in BLE & WLAN model.



Comfort Cloud-End User

High level control and energy monitoring via WLAN and cloud giving access from anywhere anytime.



H&C Control App-End User & Installer

H&C Control App makes complex initial set-up easy and allows installers to respond swiftly to clients' requests via Bluetooth.



H&C Diagnosis App-Service Partner

Provides the service partner with detailed operational data, for in-depth analysis and optimising the system.



Remote controller information

		Compatibility Table		
		CZ-RTC6BLW Built-in BLE & WLAN	CZ-RTC6BL Built-in BLE	CZ-RTC6
App		○	○	—
		○	○	—
		○	—	—

* Power supply is available only when using NX IDU

Wireless Remote Controller

* For 4 Way Cassette & Ceiling Exposed



Wired Remote Controller



CZ-RTC5B

CZ-RTC4

Simple and sophisticated design in-and-out

User friendly interface with stylish design measuring just 86 x 86 mm, CONEX is an extremely compact remote controller which perfectly matches with all kinds of modern building.



Easy control and access for end users and installers with just one remote

User-friendly day day-to-day operation for end users and simplified set up for installers.



A next-generation remote control solution optimised for usability



H&C Control App

► End user ► Installer

- Easy setting of timers and scheduling as well as monitoring power consumption.
- Fine tune the equipment to the environment.



(CZ-RTC6BL)



True-comfort for end user and installer – H&C Control App

H&C Control App makes complex initial set-up visually touch and feel easy and respond swiftly to clients' requests via Bluetooth using a smartphone or tablet.

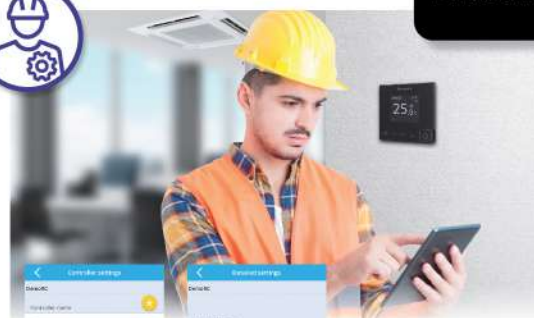

NON-INVERTER MODEL LINE-UP

PANASONIC PACKAGED AIR CONDITIONERS ARE THE IDEAL AIR CONDITIONING SOLUTIONS FOR OFFICES, EDUCATIONAL INSTITUTIONS, RESTAURANTS AND RETAIL STORES.

Panasonic provides high performance air conditioning systems that extend from homes to businesses. These products comply with stringent environmental requirements and advanced building standards in the modern commercial environment.

4-WAY CASSETTE



The 4-way direction airflow released through four vanes provides wide and even cooling.

Capacity (Btu/h)	18,100-19,100	22,300-23,000	24,900-25,000
4-WAY CASSETTE Standard Equipped nanoE ⁺ P.16-17 	 S-19PU1H5B		 S-25PU1H5B
OUTDOOR UNITS 4-WAY CASSETTE 	 U-19PN1H5		 U-25PN1H5
MINI CASSETTE P.18-19 	 CS-PV18RB4P	 CS-PV24RB4P	
FLOOR STANDING P.20-21 	 CS-J18FFP5		 CS-J28FFP8
OUTDOOR UNITS MINI CASSETTE / FLOOR STANDING 	 CU-PV18RB4P [Mini Cassette]	 CU-J18FFP5 [Floor Standing]	 CU-PV24RB4P [Mini Cassette]
4-WAY CASSETTE P.22-23 Fresh series 	 S-18PUB1H5		 S-24PUB1H5
CEILING SUSPENDED P.24-25 Fresh series 	 S-18PTB1H5		 S-24PTB1H5
CEILING DUCTED P.26-27 Fresh series 	 S-18PFB1H5		 S-24PFB1H5
OUTDOOR UNITS Fresh series 	 U-18PVB1H5		 U-24PVB1H5

MINI CASSETTE

FLOOR STANDING

4-WAY CASSETTE

CEILING SUSPENDED

CEILING DUCTED



Panasonic Mini Cassette types are compact in size and particularly suitable for small to medium-sized offices and restaurants.



The floor standing type requires little installation work, and is easy to clean.



4 discharge space provide comfort cooling to every corner of the room



The slim design makes thickness only 235mm. Can be installed horizontally and vertically



Air intake from rear as standard

30,000

36,000-36,500

42,300-48,000

48,000-60,000



S-30PU1H5B



S-36PU1H5B



S-42PU1H5B



S-50PU1H5B



U-30PN1H5 U-30PN1H8



U-36PN1H8



U-42PN1H8



U-50PN1H8



CS-J45FFP8



CU-J45FFP8*
(Floor Standing)

*3-Phase



S-30PUB1H5



S-36PUB1H5



S-48PUB1H5



S-60PUB1H5



S-30PTB1H5



S-36PTB1H5



S-48PTB1H5



S-60PTB1H5



S-30PFB1H5



S-36PFB1H5



S-48PFB1H5



S-60PFB1H5



U-30PVB1H5



U-36PVB1H8



U-48PVB1H8



U-60PVB1H8

4-WAY CASSETTE



Model No.

S-19PU1H5B S-42PU1H5B
 S-25PU1H5B S-50PU1H5B
 S-30PU1H5B
 S-36PU1H5B



TECHNICAL FOCUS

- nanoe™ X equipped as standard
- Compact design
- Low sound levels
- DC fan motor for increased efficiency
- Powerful drain pump gives 850 mm lift
- Lightweight design



Accessories

Panel



CZ-KPU3H

Selectable Remote Controller



*A wireless remote controller is in the same package with the indoor unit.



CZ-RD513C [Optional]

Capacity (Btu/h)		18,500	25,000	30,000
Power Source	V/Phase Hz	220-240 V, 1Ø Phase - 50 Hz		
Indoor		S-19PU1H5B	S-25PU1H5B	S-30PU1H5B
Outdoor		U-19PN1H5	U-25PN1H5	U-30PN1H5
Panel		CZ-KPU3H	CZ-KPU3H	CZ-KPU3H
Cooling Capacity: Rated	kW	5.42	7.33	8.79
	Btu/h	18,500	25,000	30,000
Current	A	7.1-6.5	9.6-8.8	13.5-13.2
Power Input: Rated	kW	1.52	2.07	2.85
	W/W	3.57	3.54	3.08
COP/EER	Btu/hW	12.17	12.08	10.53
Indoor Unit				
Air Volume	m ³ /min	25.0	25.0	25.0
	cfm	882	882	882
Sound Pressure Level (Hi/Lo)	dB (A)	42/35	42/35	42/35
Sound Power Level (Hi/Lo)	dB	57/50	57/50	57/50
Dimension	Indoor (H×W×D)	mm	256 × 840 × 840	256 × 840 × 840
	Panel (H×W×D)	mm	33.5 × 950 × 950	33.5 × 950 × 950
Net Weight	Indoor	kg	21	21
	Panel	kg	5	5
Outdoor Unit				
Sound Pressure Level	dB (A)	50	52	54
Sound Power Level	dB	66	68	69
Dimension	Outdoor (H×W×D)	mm	619 × 824 × 299	619 × 824 × 299
Net Weight		kg	36	42
Piping Connection	Gas Pipe	mm (inch)	12.70 (1/2)	12.70 (1/2)
	Liquid Pipe	mm (inch)	6.35 (1/4)	6.35 (1/4)
Pipe Length	Min-Max	m	7.5 - 30	7.5 - 30
Elevation Difference		m	20	20
Maximum Chargeless Length	Max	m	7.5	7.5
Refrigerant Type/Additional Gas		g/m	R32/15	R32/25
Operating Range, Outdoor	Min-Max	°C	16-43	16-43

Dimensions

A (S-19PU1H5B / S-25PU1H5B / S-30PU1H5B)

B (S-36PU1H5B / S-42PU1H5B / S-50PU1H5B)

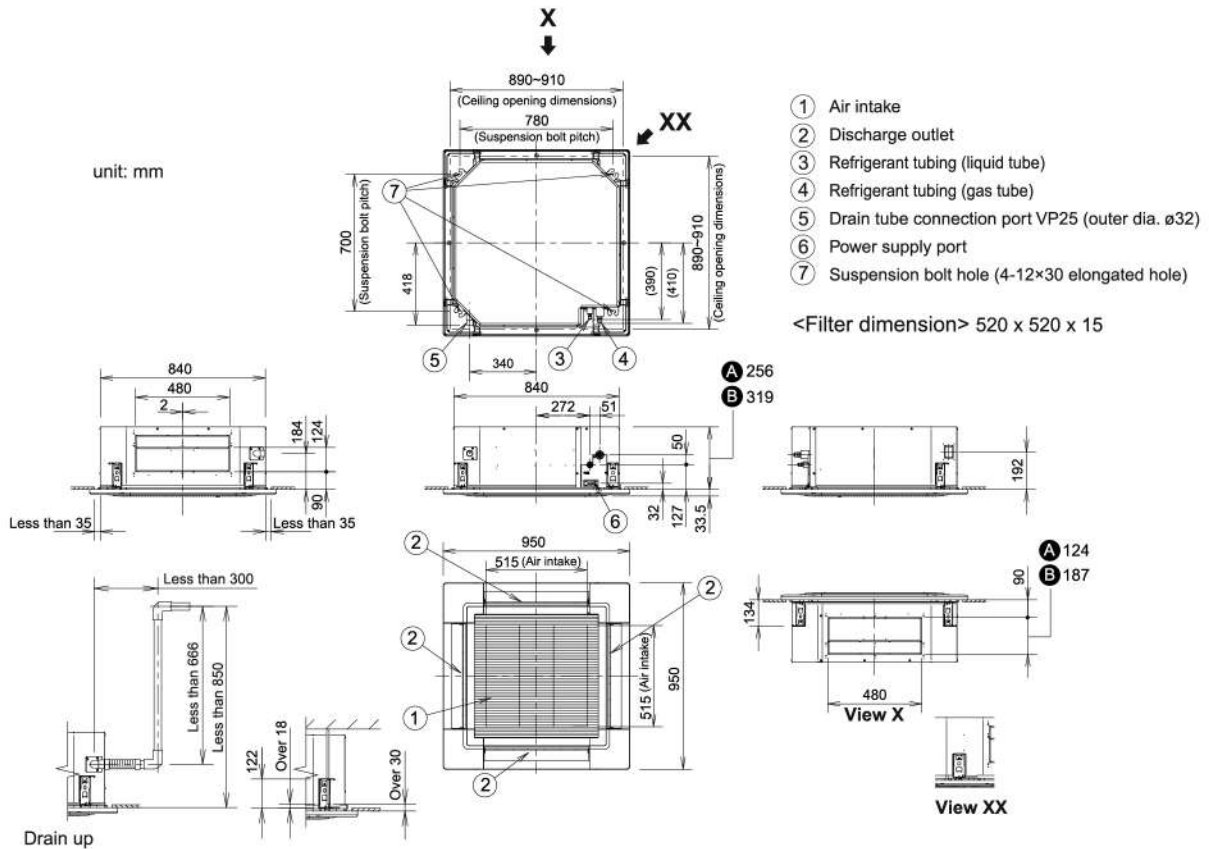

* Adjust the suspension bolt length so that the gap from the lower ceiling surface becomes 30 mm or more [18 mm or more from the lower surface of the body] as shown in the figure. When the suspension bolt length is long, it hits the ceiling panel and installation is not possible.

	30,000	36,000	42,000	48,500
	380-415 V, 3Ø Phase - 50 Hz			
	S-30PU1H5B	S-36PU1H5B	S-42PU1H5B	S-50PU1H5B
	U-30PN1H8	U-36PN1H8	U-42PN1H8	U-50PN1H8
	CZ-KPU3H	CZ-KPU3H	CZ-KPU3H	CZ-KPU3H
	8.79	10.55	12.31	14.21
	30,000	36,000	42,000	48,500
	4.5-4.3	4.9-4.6	5.4-5.3	7.4-7.6
	2.57	2.83	3.10	4.14
	3.42	3.73	3.97	3.43
	11.67	12.72	13.55	11.71
	25.0	36.4	36.4	36.4
	882	1,285	1,285	1,285
	42/35	47/41	47/41	47/41
	57/50	62/56	62/56	62/56
	256 × 840 × 840	319 × 840 × 840	319 × 840 × 840	319 × 840 × 840
	33.5 × 950 × 950	33.5 × 950 × 950	33.5 × 950 × 950	33.5 × 950 × 950
	21	24	24	24
	5	5	5	5
	54	55	58	58
	69	70	72	72
	695 × 875 × 320	695 × 875 × 320	996 × 980 × 370	996 × 980 × 370
	56	56	75	78
	15.88 [5/8]	15.88 [5/8]	15.88 [5/8]	15.88 [5/8]
	9.52 [3/8]	9.52 [3/8]	9.52 [3/8]	9.52 [3/8]
	7.5 - 45	7.5 - 45	7.5 - 50	7.5 - 50
	30	30	30	30
	7.5	7.5	7.5	7.5
	R32/25	R32/25	R32/25	R32/25
	16-43	16-43	16-43	16-43

MINI CASSETTE

Model No.
CS-PV18RB4P
CS-PV24RB4P



TECHNICAL FOCUS

- 4-Way Airflow System
- LCD Wireless Remote Controller
- Random Auto Restart
- Removable Washable Panel
- 24 Hours Real On Off Timer
- Dew Prevention Control
- Anti Freezing Control



Accessories

Panel



CZ-BT20H

Remote Controller



A wireless remote controller is in the same package with the indoor unit.

Capacity (Btu/h)		18,100	22,300
Power Source	V/Phase Hz	220 V, 1Ø Phase - 50 Hz	
Indoor		CS-PV18RB4P	CS-PV24RB4P
Outdoor		CU-PV18RB4P	CU-PV24RB4P
Panel		CZ-BT20HW	CZ-BT20HW
Cooling Capacity: Rated	kW	5.30	6.55
	Btu/h	18,100	22,300
Current	A	7.9	11.3
Power Input: Rated	kW	1.69	2.40
EER	W/W	3.14	2.73
	Btu/hW	10.71	9.29
Indoor Unit			
Air Volume	m ³ /min	13.3	13.3
Sound Pressure Level (Hi/Lo)	dB (A)	43 / 33	44 / 35
Dimension	Indoor (H×W×D)	mm	260 × 575 × 575
	Panel (H×W×D)	mm	51 × 700 × 700
Net Weight	Indoor	kg	19.0
	Panel	kg	2.5
Outdoor Unit			
Sound Pressure Level	dB (A)	52	55
Dimension	Outdoor (H×W×D)	mm	695 × 875 × 320
Net Weight		kg	47.0
Piping Connection	Gas Pipe	mm (inch)	12.70 (1/2")
	Liquid Pipe	mm (inch)	6.35 (1/4")
Pipe Length	Min~Max	m	3.0 - 25.0
Elevation Difference		m	20.0
Maximum Chargeless Length	Max	m	7.5
Additional Gas		g/m	20
Operating Range, Outdoor	Min~Max	°C	16 - 43

Dimensions

When raising the drain head above the unit

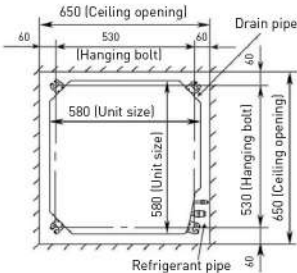
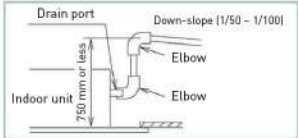

Required space for installation

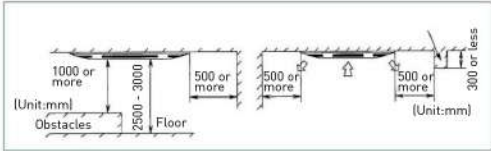

Wireless remote controller
Photo receiver unit position

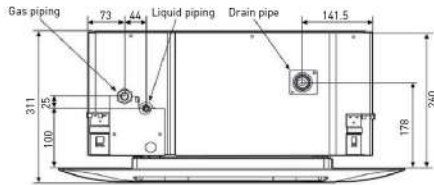
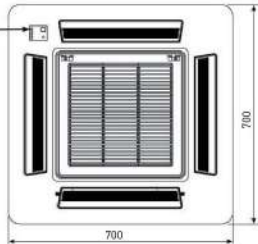

unit: mm

* The models on this page cannot be used with the remote controllers or accessories shown on page 12.

Space Savings

The compact design allows space saving.

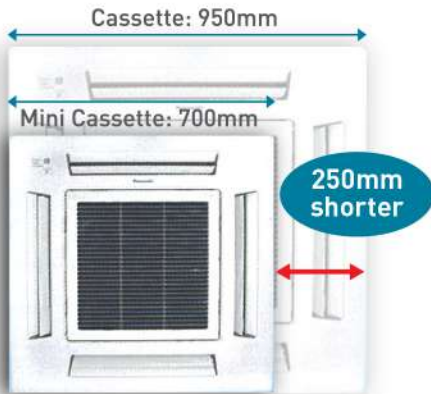

Comfort

4-Way and auto swing louvers offer comfortable and uniform airflow to all corners of room.



FLOOR STANDING

Model No.
CS-J18FFP5
CS-J28FFP8
CS-J45FFP8



TECHNICAL FOCUS

- 12-Hour On/Off Real Setting Timer
- Random Auto Restart (*2/3HP)
- Auto Fan Mode
- Self-Diagnostic Function (*5HP)
- Auto Freezing Control (2/3HP)



Remote Controller



A wireless remote controller is in the same package with the indoor unit.

Capacity (Btu/h)		19,100	24,900	42,300
Power Source	V/Phase Hz	220 V, 1Ø Phase - 50 Hz		380 V, 3Ø phase - 50Hz
Indoor		CS-J18FFP5	CS-J28FFP8	CS-J45FFP8
Outdoor		CU-J18FFP5	CU-J28FFP8	CU-J45FFP8
Cooling Capacity: Rated	kW	5.60	7.30	12.40
	Btu/h	19,100	24,900	42,300
Current	A	7.9	4.5	8.70
Power Input: Rated	kW	1.69	2.27	4.88
	W/W	3.31	3.21	2.54
EER	Btu/hW	11.30	10.96	8.66
Indoor Unit				
Air Volume	m ³ /min	15.9	16.7	27.0
Sound Pressure Level (Hi/Lo)	dB (A)	46 / 40	48 / 42	53 / 47
Dimension	Indoor (H×W×D)	mm	1,680 × 500 × 298	1,680 × 500 × 298
Net Weight		kg	30	31
Outdoor Unit				
Sound Pressure Level		dB (A)	53	54
Dimension	Outdoor (H×W×D)	mm	700 × 998 × 320	802 × 998 × 320
Net weight		kg	50.0	58.0
Piping Connection	Gas Pipe	mm (inch)	15.88 (5/8")	15.88 (5/8")
	Liquid Pipe	mm (inch)	6.35 (1/4")	9.52 (3/8")
Pipe Length	Min~Max	m	3.0 - 15.0	3.0 - 15.0
Elevation Difference			10.0	20.0
Maximum Chargeless Length	Max	m	7.0	7.0
Additional Gas		g/m	35	50
Operating Range, Outdoor	Min~Max	°C	21 - 43	21 - 43

Dimensions (CS-J18FFP5 / CS-J28FFP8)

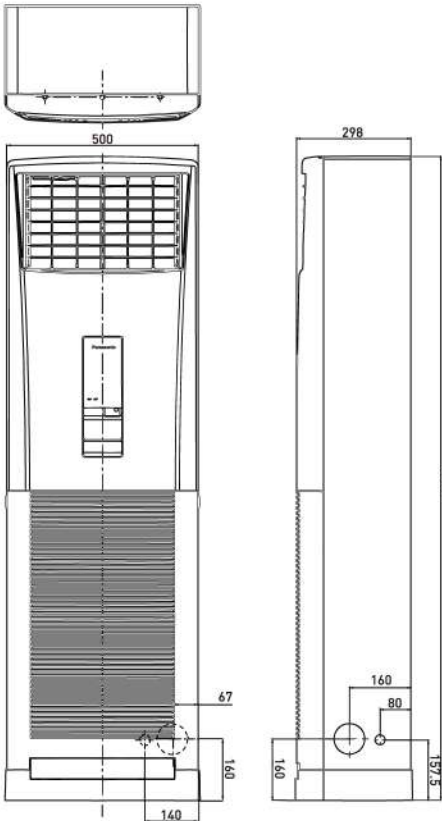

Unit:mm

Dimensions (CS-J45FFP8)

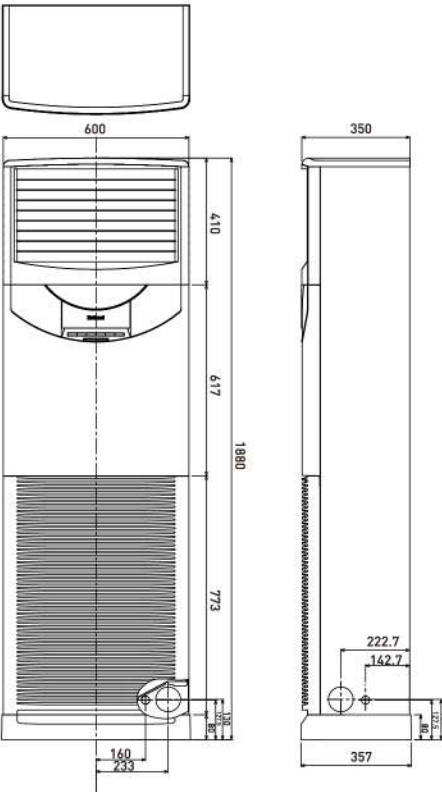

Unit:mm

4 WAY CASSETTE FRESH SERIES NON INVERTER MODEL

S-18PUB1H5 S-36PUB1H5
S-24PUB1H5 S-48PUB1H5
S-30PUB1H5 S-60PUB1H5



TECHNICAL FOCUS

- 4 discharge space provide comfort cooling to ever corner of the room
- High durability
- Easy installation
- Blue Fin technology in outdoor unit which enhanced corrosion resistance
- Copper pipe in condenser so it easy to maintain

Aksesoris Panel



CZ-KPUB1H

Remote Control



CZ-RTCB1H
(Optional)



CZ-RWCB1H
(A wireless remote controller
is in the same package with the indoor unit)



Capacity [Btu/h(Phase)]		18,000	24,000
Power Source	V/Phase Hz		220-240V, 1Ø Phase - 50 Hz
Indoor		S-18PUB1H5	S-24PUB1H5
Outdoor		U-18PVB1H5	U-24PVB1H5
Panel		CZ-KPUB1H	CZ-KPUB1H
Cooling Capacity: Rated	Kw	5,30	7,20
	Btu/h	18000	24000
Current	A	8,00	9,20
Power Input: Rated	kW	1,76	2,39
COP/EER	W/W	3,01	3,01
	[Btu/h]/W	10,27	10,27
Indoor Unit			
Air Volume	m ³ /min	10/16.6/15	21.7/16.6/15
	cfm	714/593/536	775/593/536
Sound Pressure Level (Hi//Mi/L0)	dB (A)	46/42/36	46/42/36
Sound Power Level (Hi//Mi/L0)	dB	54/50/44	54/50/44
Dimension	Indoor (HxWxD)	mm	246x840x840
	Panel (HxWxD)	mm	55x950x950
Weight [Net/Gross]	Indoor	kg	17.0/31.0
	Panel	kg	5.30/7.80
Outdoor Unit			
Sound Pressure Level	dB (A)	55	60
Sound Power Level	dB	63	68
Dimension	Outdoor (HxWxD)	mm	545x800x315
Weight [Net/Gross]		kg	36.0/39.0
Piping Connection	Gas Pipe	mm (inch)	12.7(1/2)
	Liquid Pipe	mm (inch)	6.35(1/2)
Pipe Length	Min-Max	m	30
Elevation Difference		m	15
Maximum Chargeless Length	Max	m	5
Additional Gas		gr/m	20
Operation Range, Outdoor	Min-Max	°C	17-49

4-WAY CASSETTE Dimensions

18,000 - 36,000 Btu/h

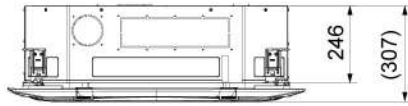

48,000 - 60,000 Btu/h

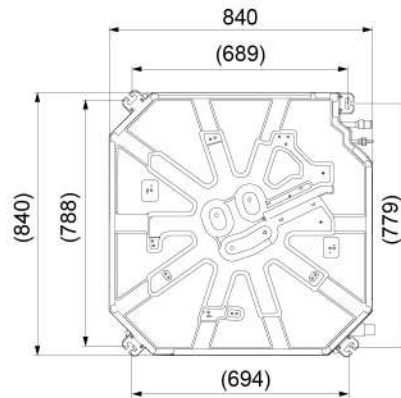
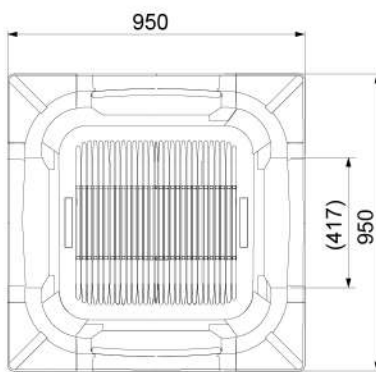
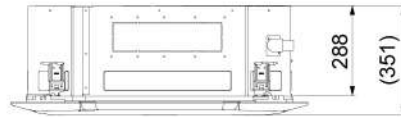

30,000	36,000	48,000	60,000
		380-415V, 3Ø Phase - 50Hz	
S-30PUB1H5	S-36PUB1H5	S-48PUB1H5	S-60PUB1H5
U-30PVB1H5	U-36PVB1H8	U-48PVB1H8	U-60PVB1H8
CZ-KPUB1H	CZ-KPUB1H	CZ-KPUB1H	CZ-KPUB1H
8,20	10,60	14,00	17,60
30000	36000	48000	60000
11,30	6,69	10,00	12,00
2,5	3,73	4,97	5,71
3,28	2,84	2,82	3,08
11,19	9,69	9,62	10,51
25/20/17.5	25/20/17.5	31.7/26.7/23.3	31.7/26.7/23.3
893/714/625	893/714/625	1132/953/832	1132/953/832
50/46/40	50/46/40	54/50/46	54/50/46
59/59/49	59/59/49	64/60/56	64/60/56
246x840x840	246x840x840	288x840x840	288x840x840
55x950x950	55x950x950	55x950x950	55x950x950
28.0/32.0	28.0/32.0	31.0/36.0	31.0/36.0
5.30/7.80	5.30/7.80	5.30/7.80	5.30/7.80
58	60	60	60
67	69	70	70
700x900x350	805x970x395	1325x940x340	1325x940x340
55.0/59.0	68.0/72.5	95.0/105.0	104.5/109.5
15.88 [5/8]	15.88 [5/8]	19.05 [3/4]	19.05 [3/4]
9.52 [3/8]	9.52 [3/8]	9.52 [3/8]	9.52 [3/8]
30	50	50	50
20	30	30	30
5	5	5	5
40	40	40	40
17-49	17-49	17-49	17-49

CEILING DUCTED NON INVERTER

S-18PFB1H5 S-36PFB1H5
 S-24PFB1H5 S-48PFB1H5
 S-30PFB1H5 S-60PFB1H5



TECHNICAL FOCUS

- Air intake from rear as standard
- Maximal cooling
- Flexible
- Easy installation and maintenance
- Blue Fin technology in outdoor unit which enhanced corrosion resistance



A wired remote controller is in the same package with the indoor unit

Capacity [Btu/h[Phase]]		18.000	24.000
Power Source	V/Phase Hz		220-240v, 1Ø Phase - 50 Hz
Indoor		S-18PFB1H5	S-24PFB1H5
Outdoor		U-18PVB1H5	U-24PVB1H5
Cooling Capacity: Rated	Kw	5,30	7,20
	Btu/h	18000	24000
Current	A	8,00	9,50
Power Input: Rated	kW	1,73	2,39
COP/EER	W/W	3,06	3,01
	[Btu/h]/W	10,44	10,27
External Static Pressure	Pa	50	50
Indoor Unit			
Air Volume	m ³ /min	15.8/13.3/11.7	21.7/20.8/19.2
	cfm	564/475/418	775/743/685
Sound Pressure Level [Hi//Mi/Lø]	dB (A)	44/41/35	47/44/38
Sound Power Level [Hi//Mi/Lø]	dB	52/49/43	55/52/46
Dimension (HxWxD)	Indoor [HxWxD]	mm	290×890×735
	Indoor Package	mm	360×1,070×800
Weight [Net/Gross]	kg	34.0/40.0	36.0/42.0
Outdoor Unit			
Sound Pressure Level	dB (A)	55	60
Sound Power Level	dB	63	68
Dimension	Outdoor [HxWxD]	mm	545×800×315
	Outdoor Package	mm	620×920×400
Weight [Net/Gross]	Kg	36.0/39.0	45.0/48.5
Piping Connection	Gas Pipe	mm [inchi]	12.7 [1/2"]
	Liquid Pipe	mm [inchi]	6.35 [1/4"]
Pipe Length	Min-Max	m	30
Elevation Difference		m	15
Maximum Chargeless Length	Max	m	5
Additional Gas		gr/m	20
Operation Range, Outdoor	Min-Max	°C	17-49

CEILING DUCTED Dimensions

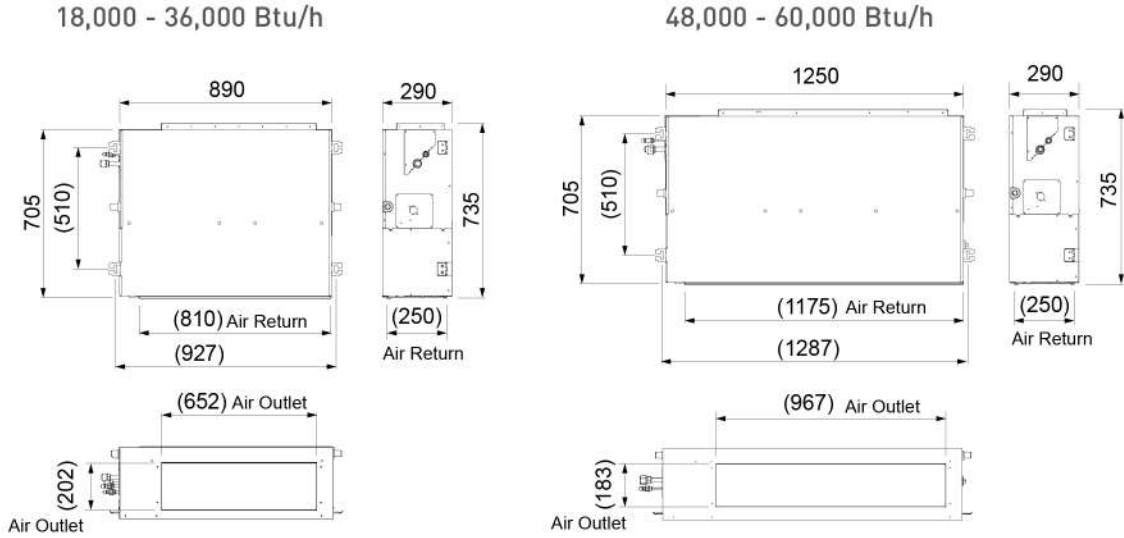

30.000	36.000	48.000	60.000
	380-415V, 3Ø Phase - 50Hz		
S-30PFB1H5	S-36PFB1H5	S-48PFB1H5	S-60PFB1H5
U-30PVB1H5	U-36PVB1H8	U-48PVB1H8	U-60PVB1H8
8,21	10,60	14,00	17,60
30000	36000	48000	60000
11,00	6,69	10,00	12,00
2,42	3,73	4,87	5,71
3,39	2,84	2,87	3,08
11,57	9,69	9,79	10,51
50	50	80	80
27.5/24.2/20.8	27.5/24.2/20.8	35/33.3/26.7	35/33.3/26.7
982/864/743	982/864/743	1,250/1,189/953	1,250/1,189/953
50/47/41	50/47/41	51/49/46	53/50/44
59/56/50	59/56/50	61/59/56	63/60/54
290×890×735	290×890×735	290×1,250×735	290×1,250×735
360×1,070×800	360×1,070×800	360×1,430×800	360×1,430×800
36.0/42.0	36.0/42.0	45.0/51.0	45.0/51.0
58	60	60	60
67	69	70	70
700×900×350	805×970×395	1,325×940×340	1,325×940×340
770×1,020×430	890×1,105×495	1,435×1,070×450	1,435×1,070×450
55.0/59.0	68.0/72.5	95.0/105.0	104.5/109.5
15.88 [5/8"]	15.88 [5/8"]	19.05 [3/4"]	19.05 [3/4"]
9.52 [3/8"]	9.52 [3/8"]	9.52 [3/8"]	9.52 [3/8"]
30	50	50	50
20	30	30	30
5	5	5	5
40	40	40	40
17-49	17-49	17-49	17-49

CEILING SUSPENDED/ CONSOLE NON INVERTER

S-18PTB1H5 S-36PTB1H5
S-24PTB1H5 S-48PTB1H5
S-30PTB1H5 S-60PTB1H5



TECHNICAL FOCUS

- The slim design makes thickness only 235mm
- Flexible model makes it can be in suspended or console position
- Blue Fin technology in outdoor unit which enhanced corrosion resistance



A wireless remote controller is in the same package with the indoor unit

CZ-RWCB1H (wireless)



(Optional)

CZ-RTCB1H (wired)

Ceiling Suspended Position



Console Position



Capacity [Btu/h[Phase]]			18,000	24,000
Power Source		V/Phase Hz		220-240v, 1Ø Phase - 50 Hz
Indoor			S-18PTB1H5	S-24PTB1H5
Outdoor			U-18PVB1H5	U-24PVB1H5
Cooling Capacity: Rated		Kw	5,30	7,20
		Btu/h	18000	24000
Current		A	8,00	9,20
Power Input: Rated		kW	1,76	2,39
		W/W	3,01	3,01
COP/EER		(Btu/h)/W	10,27	10,28
Indoor Unit				
Air Volume		m ³ /min	15.8/11.6/9.3	25.3/21/13.3
		cfm	558.8/411.7/329.4	894.1/741.1/470.5
Sound Pressure Level [Hi/Mi/Lo]		mm	44/38/33	50/46/42
Sound Power Level [Hi/Mi/Lo]		dB	52/46/41	59/55/51
Dimension	Indoor [HxWxD]	mm	690×1,000×235	690×1,280×235
	Indoor Package [HxWxD]	mm	770×1,080×325	770×1,360×325
Weight [Net/Gross]		kg	29.0/33.0	36.0/42.0
Outdoor Unit				
Sound Pressure Level		dB (A)	55	60
Sound Power Level		dB	63	68
Dimension	Outdoor [HxWxD]	mm	545×800×315	655×825×310
	Outdoor Package	mm	620×920×400	725×945×435
Weight [Net/Gross]		kg	36.0/39.0	45.0/48.5
Piping Connection	Gas Pipe	mm (inch)	12.7 [1/2"]	15.88 [5/8"]
	Liquid Pipe	mm (inch)	6.35 [1/4"]	9.52 [3/8"]
Pipe Length	Min-Max	m	30	30
Elevation Difference		m	15	20
Maximum Chargeless Length	Max	m	5	5
Additional Gas		gr/m	20	40
Operation Range, Outdoor	Min-Max	°C	17-49	17-49

CEILING & CONSOLE Dimensions

18,000 Btu/h

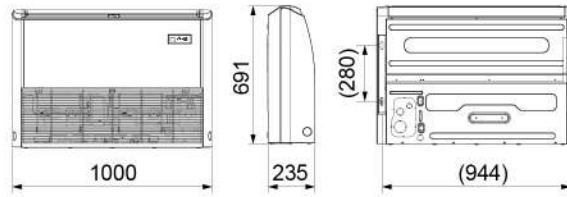

24,000 - 36,000 Btu/h

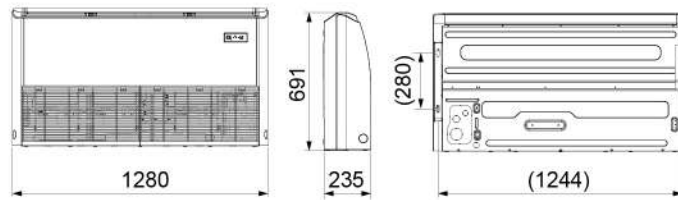

36,000 - 60,000 Btu/h

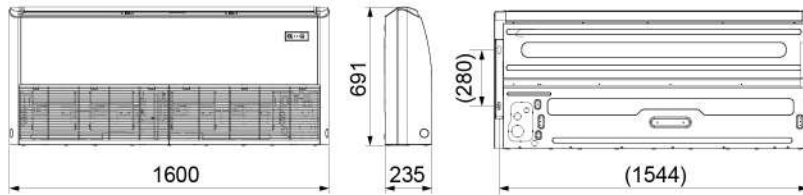

30.000	36.000	48.000	60.000
		380-415V, 3Ø Phase - 50Hz	
S-30PTB1H5	S-36PTB1H5	S-48PTB1H5	S-60PTB1H5
U-30PVB1H5	U-36PVB1H8	U-48PVB1H8	U-60PVB1H8
8,20	10,60	14,00	17,60
30000	36000	48000	60000
11,30	6,49	10,00	12,00
2,5	3,73	5	5,71
3,28	2,84	2,8	3,08
11,19	9,7	9,55	10,52
25.3/21/13.3	25.3/21/13.3	33.3/30/20.8	33.3/30/20.8
894.1/741.1/470.5	894.1/741.1/470.5	1,176.4/1,058.8/735.3	1,176.4/1,058.8/735.3
50/46/42	50/46/42	52/47/44	52/47/44
59/55/51	59/55/51	62/57/54	62/57/54
690×1,280×235	690×1,280×235	690×1,600×235	690×1,600×235
770×1,360×325	770×1,360×325	770×1,680×325	770×1,680×325
36.0/42.0	36.0/42.0	44.0/50.5	44.0/50.5
58	60	60	60
67	69	70	70
700×900×350	805×970×395	1,325×940×340	1,325×940×340
770×1,020×430	890×1,105×495	1,435×1,070×450	1,435×1,070×450
55.0/59.0	68.0/72.5	95.0/105.0	104.5/109.
15.88 [5/8"]	15.88 [5/8"]	19.05 [3/4"]	19.05 [3/4"]
9.52 [3/8"]	9.52 [3/8"]	9.52 [3/8"]	9.52 [3/8"]
30	50	50	50
20	30	30	
5	5	5	5
40	40	40	40
17-49	17-49	17-49	17-49

OUTDOOR UNITS

Dimensions (U-19PN1H5 / U-25PN1H5) 1-phase

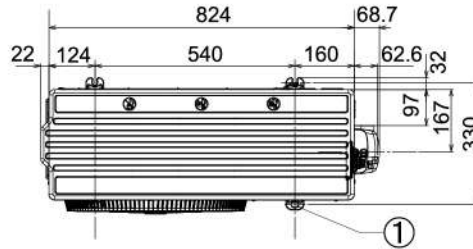
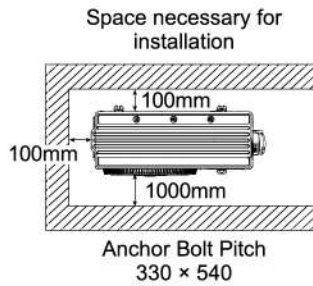

- | | |
|---|---|
| ① | Mounting hole (4-R6.5), anchor bolt : M10 |
| ② | Refrigerant tubing (liquid tube), flared connection (φ6.35) |
| ③ | Refrigerant tubing (gas tube), flared connection (φ12.70) |

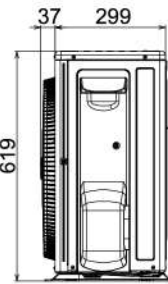
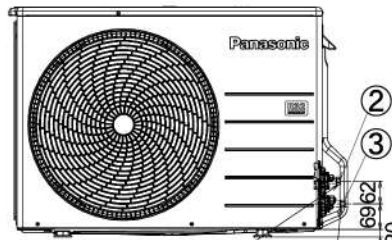
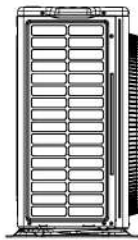

Unit:mm

2-way valve at Liquid side (High Pressure)

3-way valve at Gas side (Low Pressure)

Dimensions (U-30PN1H5) 1-phase (U-30PN1H8 / U-36PN1H8) 3-phase

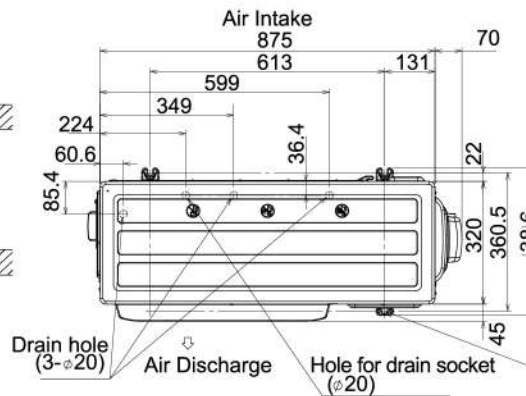
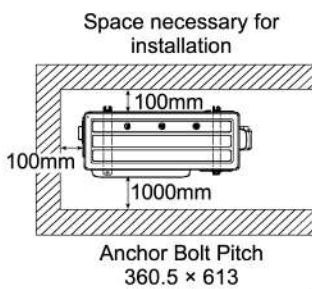

- | | |
|---|---|
| ① | Mounting hole (4-R6.5), anchor bolt : M10 |
| ② | Refrigerant tubing (liquid tube), flared connection (φ9.52) |
| ③ | Refrigerant tubing (gas tube), flared connection (φ15.88) |

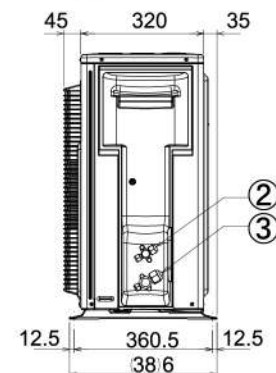
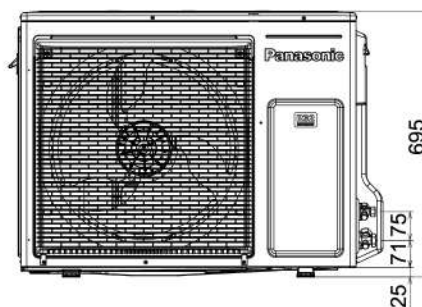
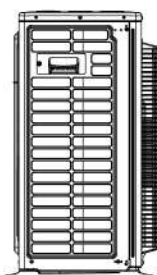

Unit:mm

Dimensions (U-42PN1H8 / U-50PN1H8) 3-phase

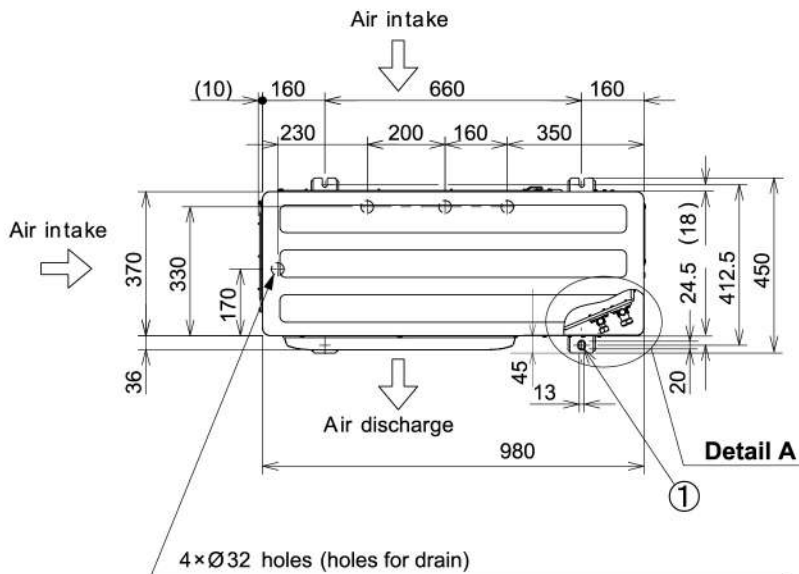

When using a drain pipe, install the drain socket (field supply) on to the drain port. Seal the other drain port with the rubber cap.

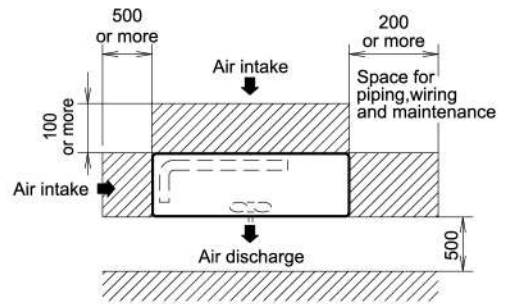

①	Mounting hole (4-R6.5), anchor bolt : M10
②	Refrigerant tubing (liquid tube), flared connection (Ø9.52)
③	Refrigerant tubing (gas tube), flared connection (Ø15.88)
④	Refrigerant tubing port
⑤	Electrical wiring port (Ø13)
⑥	Electrical wiring port (Ø22)
⑦	Electrical wiring port (Ø27)
⑧	Electrical wiring port (Ø35)

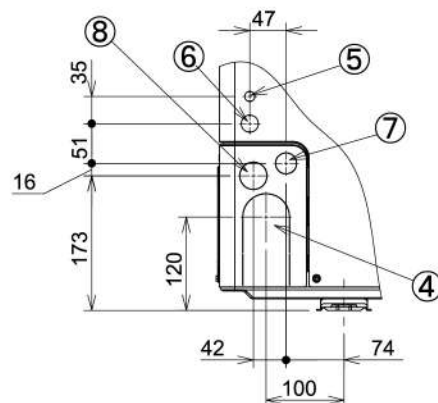
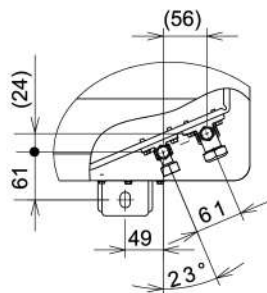
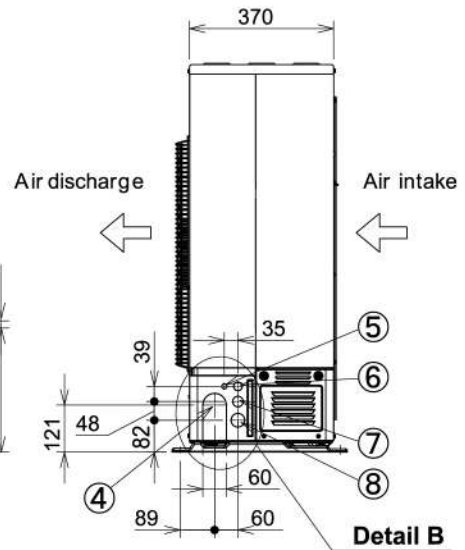
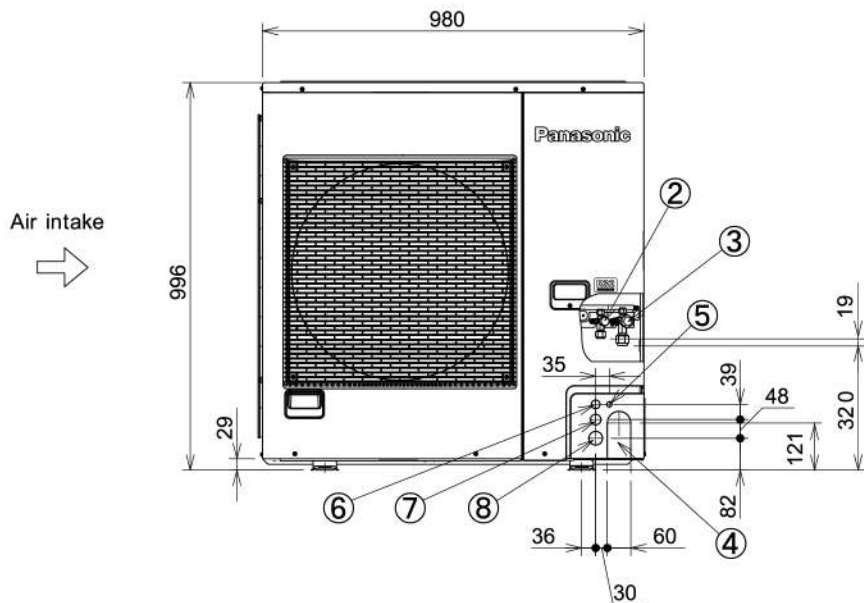

OUTDOOR UNITS

FLOOR STANDING

Dimensions [CU-J18FFP5] 1-phase [CU-J28FFP8] 3-phase

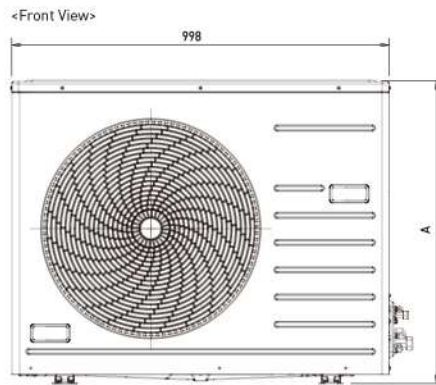
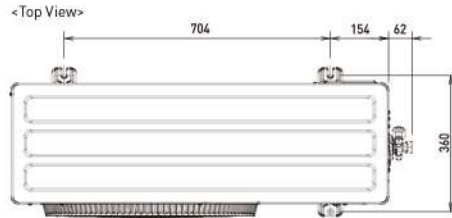

	Model number	mm
A	CU-J18FFP5	700
	CU-J28FFP8	802

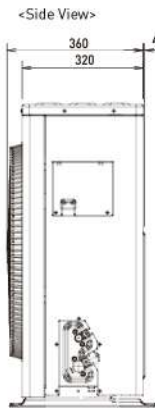

Unit:mm

Dimensions [CU-J45FFP8] 3-phase

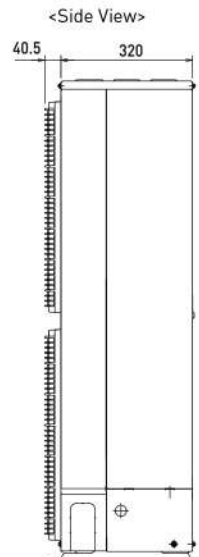
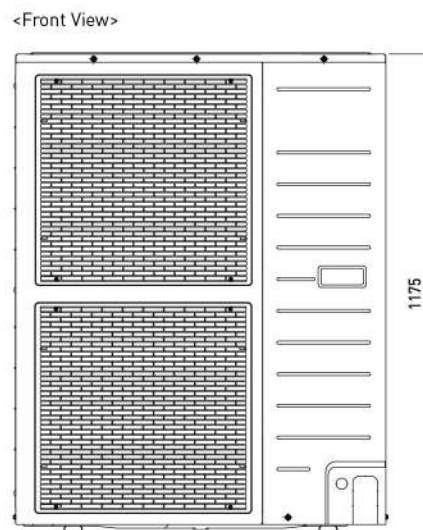
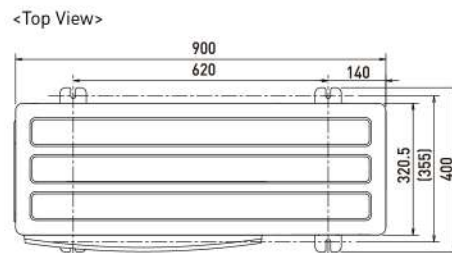

Unit:mm

MINI CASSETTE

Dimensions (CU-PV18RB4P / CU-PV24RB4P) 1-phase

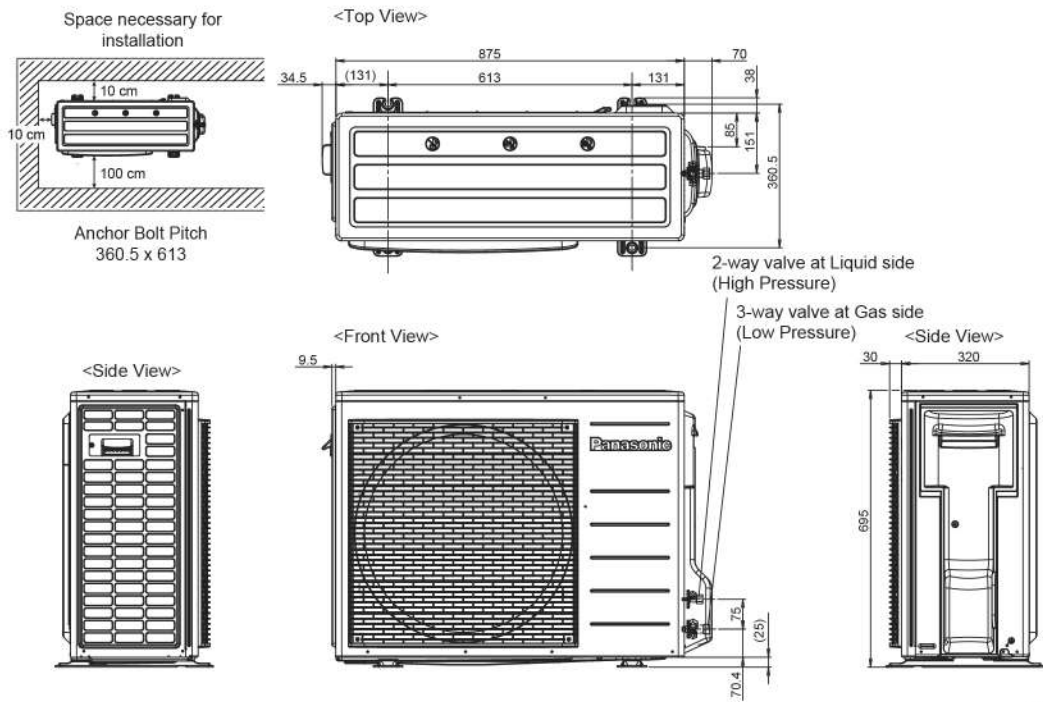



















Unit:mm

INVERTER MODEL LINE-UP

A Wide Lineup to Fit Your Needs

The wide lineup suits a variety of applications, in offices, classrooms, restaurants, shops, and more. And all outdoor units are now 1-Fan types, making them smaller and lighter than previous models. Installation and construction are also easier.

Capacity (Btu/h)	11,600-11,900	16,000-17,100	19,400-20,500	24,200
<p>NEW // 4-WAY CASSETTE</p> <p>Standard Equipped</p> <p>R32 INVERTER nanoeX Pinpoints <small>ULTRACLEAN</small> <small>COMFORT CLOUD APP</small></p> <p>P.34-35</p>		 S-1821PU3H	 S-1821PU3H	 S-2430PU3H
<p>MINI CASSETTE</p> <p>P.36-37</p> <p>R410A</p>	 CS-S12MB4PW	 CS-S18MB4PW	 CS-S24MB4PW	
<p>NEW // CEILING SUSPENDED</p> <p>R32 INVERTER nanoeX Pinpoints <small>ULTRACLEAN</small> <small>COMFORT CLOUD APP</small></p> <p>P.38-39</p>		 S-1821PT3H	 S-1821PT3H	 S-2430PT3H
<p>NEW // CEILING DUCTED</p> <p>R32 INVERTER nanoeX Pinpoints <small>ULTRACLEAN</small> <small>COMFORT CLOUD APP</small></p> <p>P.40-41</p>		 S-1821PF3H	 S-1821PF3H	 S-2430PF3H
<p>OUTDOOR UNIT</p> <p>4-WAY CASSETTE / CEILING SUSPENDED / CEILING DUCTED</p> <p>Blue Fin R32 INVERTER <small>CONDENSER</small> <small>ULTRACLEAN</small></p> <p>P.42</p>		 U-18PR1H5	 U-21PR1H5	 U-24PR1H5
<p>OUTDOOR UNIT</p> <p>MINI CASSETTE</p> <p>P.43</p>	 CU-S12MBP	 CU-S18MBP	 CU-S24MBP	

NEW

4-WAY CASSETTE



The 4-way direction airflow released through four vanes provides wide and even cooling.

MINI CASSETTE



Mini Cassette types equipped with the 4-way airflow system are compact in size and particularly suitable for small to medium-sized offices and restaurants.

NEW

CEILING SUSPENDED



Providing outstanding energy-saving performance, comfort and long-distance air flow distribution, these units are perfect for retail stores and schools.

NEW

CEILING DUCTED



Offering remarkable overall cooling coverage of the entire building, Ceiling Ducted types are suitable for premises with concealed or false ceilings such as business centres and can be mounted horizontally and vertically.

29,000

34,100

42,700-47,800

42,700 (3)-47,800 (3)



S-2430PU3H



S-3448PU3H



S-3448PU3H



S-3448PU3H



S-3448PU3H



S-3448PU3H



S-2430PT3H



S-3448PT3H



S-3448PT3H



S-3448PT3H



S-3448PT3H



S-3448PT3H



S-2430PF3H



S-3448PF3H



S-3448PF3H



S-3448PF3H



S-3448PF3H



S-3448PF3H



U-30PR1H5



U-34PR1H5



U-43PR1H5



U-48PR1H5



U-43PR1H8



U-48PR1H8

4-WAY CASSETTE NEW

Model No.
S-1821PU3H (2-2.5PK)
S-2430PU3H (3-3.5PK)
S-3448PU3H (4-6PK)



TECHNICAL FOCUS

- nanoe™X for air purification
- Smart Comfort with CONEX offering IoT Integration that connects directly to a variety of apps
- Powerful, 360° wide & comfortable airflow
- Wide Flap
- Compact, modern and flat panel design
- Blue Fin technology in outdoor unit which enhanced corrosion resistance
- Easy installation



Accessories



CZ-KPU3H



CZ-RTC5B



CZ-RTC4



CZ-RTC6
CZ-RTC6BL [BLE]
CZ-RTC6BLW [BLE&WLAN]



[Optional]
If not use
CZ-RTC6BLW,
The adaptor also
can be used.

CZ-CAPWFC1

Capacity [Btu/h(Phase)]			17,100	20,500	24,200
Power Source		V/Phase Hz			220-240v
Indoor			S-1821PU3H	S-1821PU3H	S-2430PU3H
Outdoor			U-18PR1H5	U-21PR1H5	U-24PR1H5
Panel			CZ-KPU3H	CZ-KPU3H	CZ-KPU3H
Cooling Capacity: Rated [Min-Max]		kW [min-max]	5.00 [2.00-5.60]	6.00 [2.00-6.30]	7.10 [1.20-8.00]
		Btu/h [min-max]	17,100 [6,820-19,100]	20,500 [6,820-21,500]	24,200 [7,170-27,300]
Current: Rated [Min-Max]		A	5.2-5.5	7.5-8.0	8.5-9.2
Power Input: Rated [Min-Max]		kW	1.14 [0.38-1.50]	1.71 [0.38-2.10]	1.99 [0.30-2.26]
COP/EER		W/W	4.39	3.51	3.57
		Btu/hW	15	11.99	12.16
Indoor Unit					
Air Volume		m ³ /min	25,0	25,0	25,0
		cfm	882	882	882
Sound Pressure Level [Hi/Lo]		dB [A]	42 / 35	42 / 35	42 / 35
Sound Power Level [Hi/Lo]		dB	57 / 50	57 / 50	57 / 50
Dimension	Indoor [HxWxD]	mm	256 x 840 x 840	256 x 840 x 840	256 x 840 x 840
	Panel [HxWxD]	mm	44 x 950 x 950	44 x 950 x 950	44 x 950 x 950
Net Weight	Indoor	kg	21	21	21
	Panel	kg	5	5	5
Outdoor Unit					
Sound Pressure Level		dB [A]	49	50	51
Sound Power Level		dB	68	69	70
Dimension	Outdoor [HxWxD]	mm	619 x 824 x 299	619 x 824 x 299	619 x 824 x 299
Net Weight		kg	29	29	33
Piping Connection	Gas Pipe	mm [inch]	12.70 [1/2]	12.70 [1/2]	15.88 (5/8)
	Liquid Pipe	mm [inch]	6.35 [1/4]	6.35 [1/4]	9.52 (3/8)
Pipe Length	Min-Max	m	5-30	5-30	5-30
Elevation Difference		m	20	20	20
Maximum Chargeless Length	Max	m	15	15	15
Additional Gas		gr/m	10	10	10
Operation Range, Outdoor	Min-Max	°C	16-46	16-46	16-46

Dimensions

- A** S-1821PU3H/S-2430PU3H
- B** S-3448PU3H

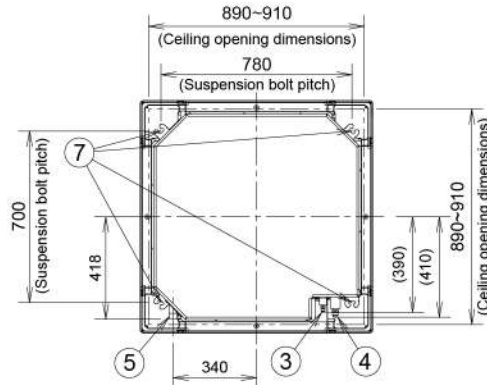

- 1 Air intake
- 2 Discharge outlet
- 3 Refrigerant tubing (liquid tube)
- 4 Refrigerant tubing (gas tube)
- 5 Drain tube connection port VP25 (outer dia. ø32)
- 6 Power supply port
- 7 Suspension bolt hole (4-12x30 elongated hole)

<Filter dimension> 520 x 520 x 15

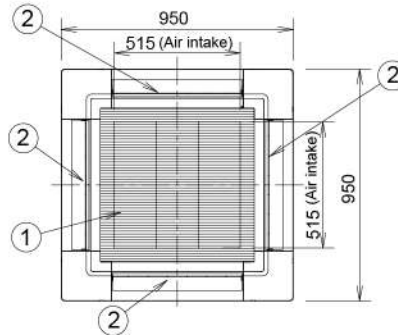
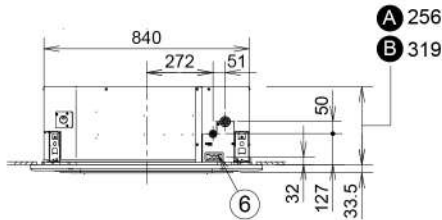

unit:mm

29.000	34.100	42.700	42700 [3]	47.800	47800 [3]
1Ø Phase - 50 Hz			3Ø Phase - 50Hz		3Ø Phase - 50Hz
S-2430PU3H	S-3448PU3H	S-3448PU3H	S-3448PU3H	S-3448PU3H	S-3448PU3H
U-30PR1H5	U-34PR1H5	U-43PR1H5	U-43PR1H8	U-48PR1H5	U-48PR1H8
CZ-KPU3H	CZ-KPU3H	CZ-KPU3H	CZ-KPU3H	CZ-KPU3H	CZ-KPU3H
8.50[2.10-10.00]	10.00[3.20-11.20]	12.50[3.80-14.00]	12.50[3.80-14.00]	14.00[3.80-14.71]	14.00[3.80-14.71]
29.000[7.170-34.100]	34.100[10.900-38.200]	42.700[13.000-47.800]	42.700[13.000-47.800]	47.800[13.000-50.200]	47.800[13.000-50.200]
10.7-11.7	13.7-15.0	16.9-18.5	5.6-6.1	21.9-23.9	7.2-7.9
2.52 [0.28-3.33]	3.23 [0.61-3.73]	3.74 [0.63-4.25]	3.74 [0.63-4.25]	4.83 [0.63-5.10]	4.83 [0.63-5.10]
3.37	3.1	3.34	3.34	2.9	2.9
11.51	10.56	11.42	11.42	9.9	9.9
25.0	36.4	36.4	36.4	36.4	36.4
882	1.285	1.285	1.285	1.285	1.285
42 / 35	47 / 41	47 / 41	47 / 41	47 / 41	47 / 41
57 / 50	62 / 56	62 / 56	62 / 56	62 / 56	62 / 56
256 x 840 x 840	319 x 840 x 840	319 x 840 x 840	319 x 840 x 840	319 x 840 x 840	319 x 840 x 840
44 x 950 x 950	44 x 950 x 950	44 x 950 x 950	44 x 950 x 950	44 x 950 x 950	44 x 950 x 950
21	24	24	24	24	24
5	5	5	5	5	5
53	55	57	57	58	58
72	74	76	76	77	77
695 x 875 x 320	695 x 875 x 320	996 x 980 x 370	996 x 980 x 370	996 x 980 x 370	996 x 980 x 370
39	48	68	67	68	67
15.88 (5/8)	15.88 (5/8)	15.88 (5/8)	15.88 (5/8)	15.88 (5/8)	15.88 (5/8)
9.52 (3/8)	9.52 (3/8)	9.52 (3/8)	9.52 (3/8)	9.52 (3/8)	9.52 (3/8)
5-50	5-50	5-50	5-50	5-50	5-50
30	30	30	30	30	30
25	25	25	25	25	25
30	30	30	30	30	30
16-46	16-46	16-46	16-46	16-46	16-46

MINI CASSETTE

Model No.
CS-S12MB4PW
CS-S18MB4PW
CS-S24MB4PW



TECHNICAL FOCUS

- 4-Way Airflow System
- LCD Wireless Remote Controller
- Random Auto Restart
- Removable Washable Panel
- 24 Hours Real On Off Timer
- Dew Prevention Control
- Anti Freezing Control



Accessories

Panel



CZ-BT20E

Selectable Remote Controller



A wireless remote controller is in the same package with the indoor unit.

Capacity (Btu/h)		11,600
Power Source	V/Phase Hz	
Indoor		CS-S12MB4PW
Outdoor		CU-S12MBP
Panel		CZ-BT20EW
Cooling Capacity: Rated (Min-Max)	kW	3.40 (0.93-4.40)
	Btu/h	11,600 (3,170-15,000)
Current: Rated	A	4.8
Power Input: Rated (Min-Max)	kW	0.98 (0.26-1.33)
	W/W	3.47
COP / EER		
	Btu/hW	11.84
Indoor Unit		
Air Volume	m ³ /min	10.5
Sound Pressure Level* (Hi/L0/Q-Lo)	dB (A)	34 / 26 / 23
Dimension	Indoor (H×W×D)	mm 260 × 575 × 575
	Panel (H×W×D)	mm 51 × 700 × 700
Net Weight	Indoor	kg 18.0
	Panel	kg 2.5
Outdoor Unit		
Sound Pressure Level (Hi)	dB (A)	47
Dimension	Outdoor (H×W×D)	mm 540 × 780 × 289
Net Weight	kg	31.0
Piping Connection	Gas Pipe	mm (inch) 12.70 (1/2)
	Liquid Pipe	mm (inch) 6.35 (1/4)
Pipe Length	Min-Max	m 3.0-15.0
Elevation Difference	m	15.0
Maximum Chargeless Length	Max	m 7.5
Additional Gas	g/m	15
Operating Range, Outdoor	Min-Max	°C 16-43

Dimensions

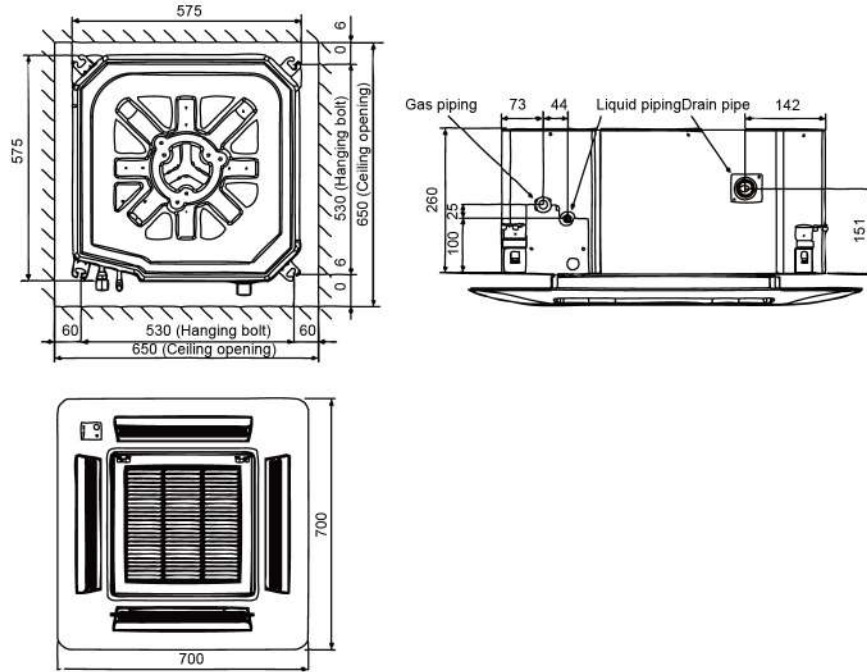

When raising the drain head above the unit

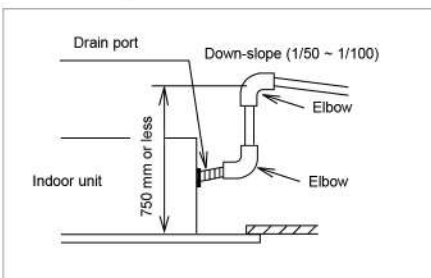

Required space for installation

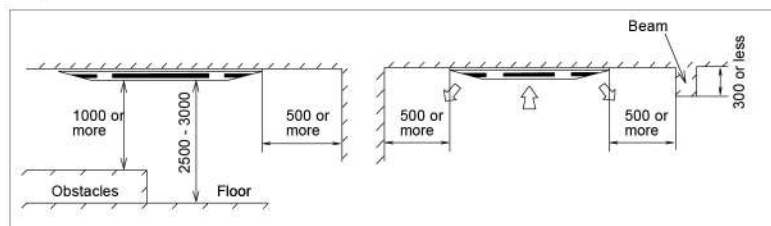

unit: mm

16,000	19,400
220 V, 1Ø Phase - 50 Hz	
CS-S18MB4PW	CS-S24MB4PW
CU-S18MBP	CU-S24MBP
CZ-BT20EW	CZ-BT20EW
4.70 [0.98-5.60]	5.70 [0.98-6.60]
16,000 [3,340-19,100]	19,400 [3,340-22,500]
6.3	8.5
1.34 [0.27-1.65]	1.82 [0.30-2.15]
3.51	3.13
11.94	10.66
11.3	12.8
38 / 28 / 25	41 / 33 / 30
260 × 575 × 575	260 × 575 × 575
51 × 700 × 700	51 × 700 × 700
18.0	18.0
2.5	2.5
49	49
695 × 875 × 320	695 × 875 × 320
44.0	44.0
12.70 [1/2]	15.88 [5/8]
6.35 [1/4]	6.35 [1/4]
3.0-20.0	3.0-20.0
15.0	15.0
10.0	10.0
15	20
16-43	16-43

CEILING SUSPENDED NEW

Model No.
S-1821PT3H (2-2.5PK)
S-2430PT3H (3-3.5PK)
S-3448PT3H (4-6PK)

nanoe™X

R32
REFRIGERANT

INVERTER

Panasonic
Comfort Cloud App

Technical Focus

- nanoe™X for air purification
- Smart Comfort with CONEX offering IoT Integration that connects directly to a variety of apps
- Slim design with thickness only 235 mm
- Compact looking, stylish, one-motion design
- Comfortable, long-distance airflow distribution
- Blue Fin technology in outdoor unit which enhanced corrosion resistance



Accessories

(Optional Wired Remote Controller)



CZ-RTC5B



CZ-RTC4



CZ-RTC6
CZ-RTC6BL [BLE]
CZ-RTC6BLW [BLE&WLAN]



CZ-CAPWFC1

(Optional)
If not use
CZ-RTC6BLW,
The adaptor also
can be used.

Capacity [Btu/h(Phase)]			17.100	20.500	24.200
Power Source		V/Phase Hz			220-240v,
Indoor			S-1821PT3H	S-1821PT3H	S-2430PT3H
Outdoor			U-18PR1H5	U-21PR1H5	U-24PR1H5
Cooling Capacity: Rated (Min-Max)		kW (min-max)	5.00 (2.00-5.60)	6.00 (2.00-6.30)	7.10(2.00-7.80)
		Btu/h (min-max)	17,100 (6,820-19,100)	20,500 (6,820-21,500)	24,200 (6,820-26,600)
Current: Rated (Min-Max)		A	5.9-6.2	8.4-9.0	8.9-9.7
Power Input: Rated (Min-Max)		kW	1.33 (0.39-1.65)	1.92 (0.39-2.25)	2.00 (0.32-2.36)
COP/EER		W/W	3.76	3.13	3.38
		Btu/hW	12.86	10.68	11.52
Indoor Unit					
Air Volume		m ³ /min	15.0	15.0	21.0
		cfm	530	530	740
Sound Pressure Level (Hi/Lo)		dB (A)	38 / 29	38 / 29	40 / 32
Sound Power Level (Hi/Lo)		dB	56 / 47	56 / 47	58 / 50
Dimension	Indoor [HxWxD]	mm	235 x 960 x 960	235 x 960 x 960	235 x 1275 x 690
Net Weight	Indoor	kg	26	26	34
Outdoor Unit					
Sound Pressure Level		dB (A)	50	51	51
Sound Power Level		dB	69	70	70
Dimension	Outdoor [HxWxD]	mm	619 x 824 x 299	619 x 824 x 299	619 x 824 x 299
Net Weight		kg	29	29	33
Piping Connection	Gas Pipe	mm (inch)	12.70 (1/2)	12.70 (1/2)	15.88 (5/8)
	Liquid Pipe	mm (inch)	6.35 (1/4)	6.35 (1/4)	9.52 (3/8)
Pipe Length	Min-Max	m	5-30	5-30	5-30
Elevation Difference		m	20	20	20
Maximum Chargeless Length	Max	m	15	15	15
Additional Gas		gr/m	10	10	10
Operation Range, Outdoor	Min-Max	°C	16-46	16-46	16-46

Dimensions

S-1821PT3H

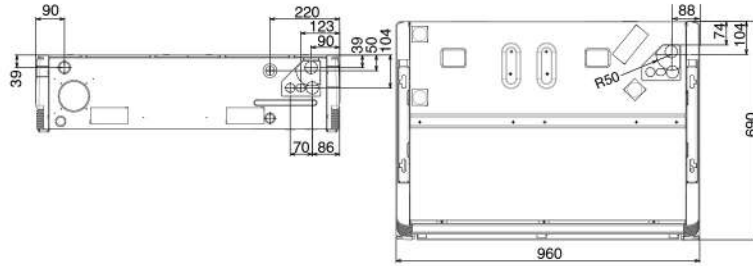

S-2430PT3H

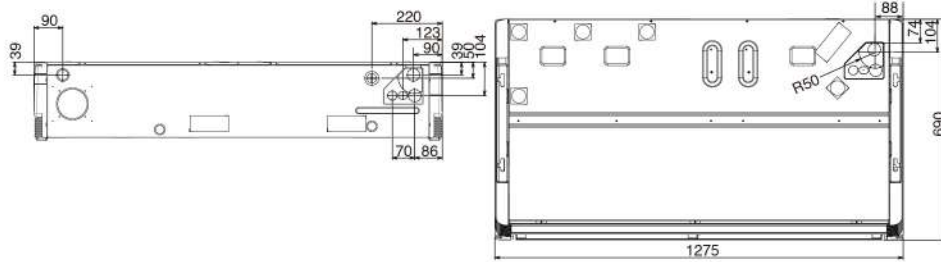

S-3448PT3H

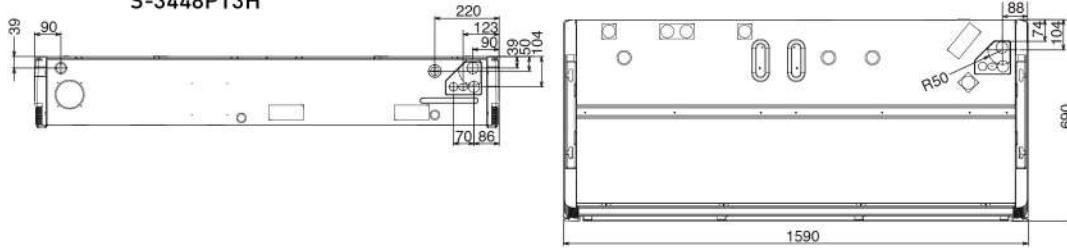

unit:mm

29.000	34.100	42.700	42700 (3)	45.500	45500 (3)
1Ø Phase - 50 Hz			380-415V, 3Ø Phase - 50Hz	220-240V, 1Ø Phase - 50 Hz	380-415V, 3Ø Phase - 50 Hz
S-2430PT3H	S-3448PT3H	S-3448PT3H	S-3448PT3H	S-3448PT3H	S-3448PT3H
U-30PR1H5	U-34PR1H5	U-43PR1H5	U-43PR1H8	U-48PR1H5	U-48PR1H8
8.50 [2.00-9.60]	10.00 [3.20-11.20]	12.50 [3.80-13.54]	12.50 [3.80-13.54]	13.33 [3.80-14.00]	13.33 [3.80-14.00]
29,000 [6,820-32,800]	34,100 [10,900-38,200]	42,700 [13,000-46,200]	42,700 [13,000-46,200]	45,400 [13,000-47,800]	45,400 [13,000-47,800]
11.7-12.8	14.3-15.6	18.6-20.3	6.1-6.7	20.4-22.2	6.7-7.4
2.75 [0.29-3.31]	3.36 [0.58-3.77]	4.10 [0.68-4.50]	4.10 [0.68-4.50]	4.50 [0.68-4.80]	4.50 [0.68-4.80]
3.09	2.98	3.05	3.05	2.96	2.96
10.55	10.15	10.41	10.41	10.11	10.11
21.0	35.0	35.0	35.0	35.0	35.0
740	1235	1235	1235	1235	1235
40 / 32	46 / 38	46 / 38	46 / 38	46 / 38	46 / 38
58 / 50	64 / 56	64 / 56	64 / 56	64 / 56	64 / 56
235 x 1275 x 690	235 x 1590 x 690	235 x 1590 x 690	235 x 1590 x 690	235 x 1590 x 690	235 x 1590 x 690
34	40	40	40	40	40
53	55	57	57	58	58
72	74	76	76	77	77
695 x 875 x 320	695 x 875 x 320	996 x 980 x 370	996 x 980 x 370	996 x 980 x 370	996 x 980 x 370
39	48	68	67	68	67
15.88 [5/8]	15.88 [5/8]	15.88 [5/8]	15.88 [5/8]	15.88 [5/8]	15.88 [5/8]
9.52 [3/8]	9.52 [3/8]	9.52 [3/8]	9.52 [3/8]	9.52 [3/8]	9.52 [3/8]
5-50	5-50	5-50	5-50	5-50	5-50
30	30	30	30	30	30
25	25	25	25	25	25
30	30	30	30	30	30
16-46	16-46	16-46	16-46	16-46	16-46

CEILING DUCTED NEW

Model No.
S-1821PF3H (2-2.5PK)
S-2430PF3H (3-3.5PK)
S-3448PF3H (4-6PK)



Technical Focus

- nanoe™X for air purification
- Smart Comfort with CONEX offering IoT Integration that connects directly to a variety of apps
- Industry-leading horizontal and vertical design
- Compact body with powerful 150 Pa ESP
- Space saving 250 mm height, filter included
- Blue Fin technology in outdoor unit which enhanced corrosion resistance
- Can be mounted horizontally and vertically



Accessories

(Optional Wired Remote Controller)



CZ-RTC5B



CZ-RTC4



CZ-RTC6
CZ-RTC6BL [BLE]
CZ-RTC6BLW [BLE&WLAN]



CZ-CAPWFC1

[Optional]
If not use
CZ-RTC6BLW,
The adaptor also
can be used.

Space saving 250 mm height



Capacity [Btu/h(Phase)]		17,100	20,500	24,200
Power Source	V/Phase Hz			220-240V
Indoor		S-1821PF3H	S-1821PF3H	S-2430PF3H
Outdoor		U-18PR1H5	U-21PR1H5	U-24PR1H5
Cooling Capacity: Rated (Min-Max)	kW (min-max)	5.00 [2.00-5.60]	6.00 [2.00-6.30]	7.10 [2.00-7.60]
	Btu/h [min-max]	17,100 [6,820-19,100]	20,500 [6,820-21,500]	24,200 [6,820-25,900]
Current: Rated (Min-Max)	A	6.8-7.2	8.6-9.1	9.7-10.5
Power Input: Rated (Min-Max)	kW	1.54 [0.41-1.75]	1.95 [0.41-2.30]	2.27 [0.34-2.48]
COP/EER	W/W	3.25	3.08	3.13
	Btu/hW	11.1	10.51	10.66
Indoor Unit				
Air Volume	m ³ /min	16.0	16.0	21.0
	cfm	565	565	740
Sound Pressure Level (Hi/Lo)	dB (A)	35 / 29	35 / 29	35 / 29
Sound Power Level (Hi/Lo)	dB	58 / 52	58 / 52	58 / 52
Dimension	Indoor (HxWxD)	mm	250 x 800 x 730	250 x 800 x 730
Net Weight	Indoor	kg	25	30
Outdoor Unit				
Sound Pressure Level	dB (A)	50	51	51
Sound Power Level	dB	69	70	70
Dimension	Outdoor (HxWxD)	mm	619 x 824 x 299	619 x 824 x 299
Net Weight		kg	29	33
Piping Connection	Gas Pipe	mm (inch)	12.7 (1/2)	15.88 (5/8)
	Liquid Pipe	mm (inch)	6.35 (1/4)	9.52 (3/8)
Pipe Length	Min-Max	m	5-30	5-30
Elevation Difference		m	20	20
Maximum Chargeless Length	Max	m	15	15
Additional Gas		gr/m	10	10
Operation Range, Outdoor	Min-Max	°C	16-46	16-46

S-1821PF3H/S-2430PF3H/S-3448PF3H

Detailed dimensions of indoor unit

Type	A	B	C	D	E	F
	mm	mm	mm	mm	mm	Q'ty
1821	867	800	450 (Pitch 150 x 3)	71	592	12
2430	1,067	1,000	750 (Pitch 150 x 5)	21	792	16
3448	1,467	1,400	1,050 (Pitch 150 x 7)	71	1,192	20

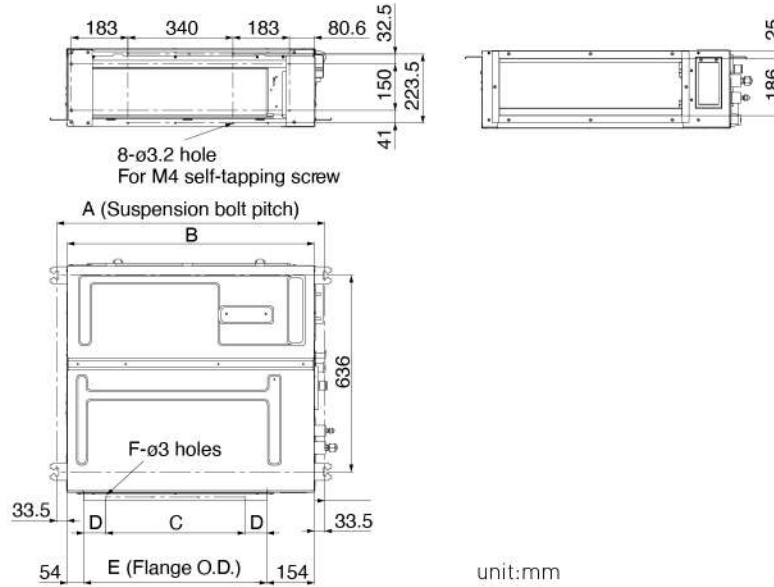

27.600	34.100	42.700	42700 [3]	47.000	47000 [3]
1Ø Phase - 50 Hz					
S-2430PF3H	S-3448PF3H	S-3448PF3H	S-3448PF3H	S-3448PF3H	S-3448PF3H
U-30PR1H5	U-34PR1H5	U-43PR1H5	U-43PR1H8	U-48PR1H5	U-48PR1H8
8.10 [2.00-8.90]	10.00 [3.20-11.20]	12.50 [3.80-13.50]	12.50 [3.80-13.50]	13.77 [3.80-14.20]	13.77 [3.80-14.20]
27,600 [6,820-30,400]	34,100 [10,900-38,200]	42,700 [13,000-46,100]	42,700 [13,000-46,100]	47,000 [13,000-48,500]	47,000 [13,000-48,500]
11.1-12.1	13.3-14.5	17.9-19.6	5.9-6.5	21.6-23.6	7.1-7.8
2.60 [0.33-2.90]	3.12 [0.59-3.65]	3.96 [0.65-4.35]	3.96 [0.65-4.35]	4.77 [0.65-4.95]	4.77 [0.65-4.95]
3.12	3.21	3.16	3.16	2.89	2.89
10,62	10,93	10,78	10,78	9,85	9,85
21,0	36,0	36,0	36,0	36,0	36,0
740	1.270	1.270	1.270	1.270	1.270
35 / 29	40 / 30	40 / 30	40 / 30	40 / 30	40 / 30
58 / 52	63 / 53	63 / 53	63 / 53	63 / 53	63 / 53
250 x 1000 x 730	250 x 1400 x 730	250 x 1400 x 730	250 x 1400 x 730	250 x 1400 x 730	250 x 1400 x 730
30	39	39	39	39	39
53	55	57	57	58	58
72	74	76	76	77	77
695 x 875 x 320	695 x 875 x 320	996 x 980 x 370	996 x 980 x 370	996 x 980 x 370	996 x 980 x 370
39	48	68	67	68	67
15.88 [5/8]	15.88 [5/8]	15.88 [5/8]	15.88 [5/8]	15.88 [5/8]	15.88 [5/8]
9.52 [3/8]	9.52 [3/8]	9.52 [3/8]	9.52 [3/8]	9.52 [3/8]	9.52 [3/8]
5-50	5-50	5-50	5-50	5-50	5-50
30	30	30	30	30	30
25	25	25	25	25	25
30	30	30	30	30	30
16-46	16-46	16-46	16-46	16-46	16-46

OUTDOOR UNITS

OUTDOOR UNITS **NEW** Dimensions

U-18PR1H5/U-21PR1H5/U-24PR1H5

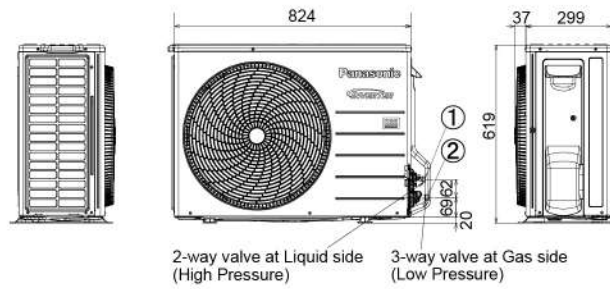

- | | |
|---|--|
| ① | Refrigerant tubing (liquid tube), flared connection (φ6.35"/9.52") |
| ② | Refrigerant tubing (gas tube), flared connection (φ12.70"/15.88") |

*1 U-18/21PR1H5
 *2 U-24PR1H5
 *Mounting hole (4-R6.5), anchor bolt : M10

U-30PR1H5/U-34PR1H5

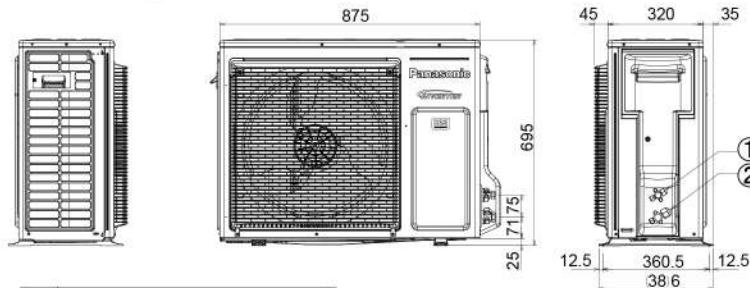

- | | |
|---|---|
| ① | Refrigerant tubing (liquid tube), flared connection (φ9.52) |
| ② | Refrigerant tubing (gas tube), flared connection (φ15.88) |

*Mounting hole (4-R6.5), anchor bolt : M10

Unit:mm

U-43PR1H5/U-43PR1H8/U-48PR1H5/U-48PR1H8

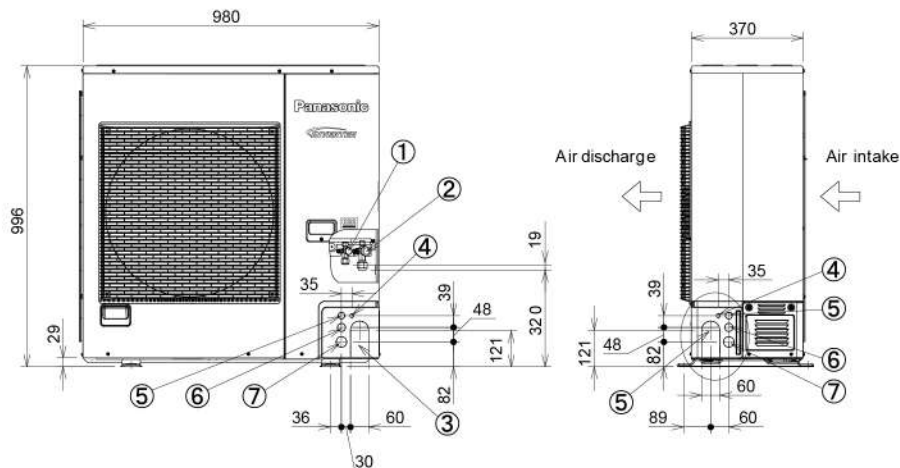

- | | |
|---|---|
| ① | Refrigerant tubing (liquid tube), flared connection (Ø9.52) |
| ② | Refrigerant tubing (gas tube), flared connection (Ø15.88) |
| ③ | Refrigerant tubing port |
| ④ | Electrical wiring port (Ø13) |
| ⑤ | Electrical wiring port (Ø22) |
| ⑥ | Electrical wiring port (Ø27) |
| ⑦ | Electrical wiring port (Ø35) |

*Mounting hole (4-R6.5), anchor bolt : M10

Unit:mm

MINI CASSETTE

Dimensions (CU-S12MBP) 1-phase

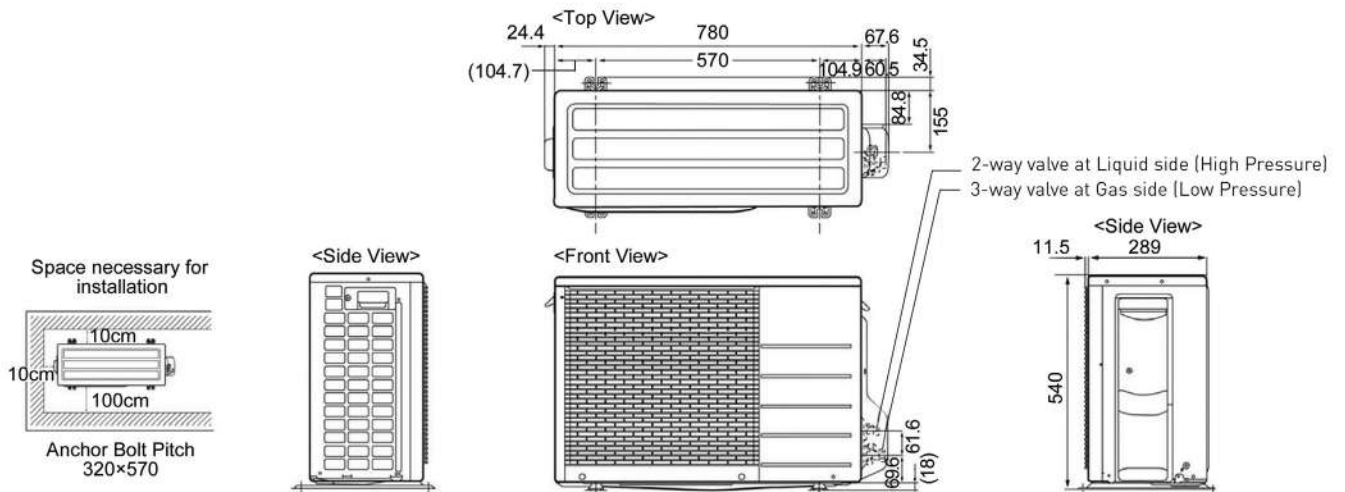

Unit:mm

Dimensions (CU-S18MBP / CU-S24MBP) 1-phase

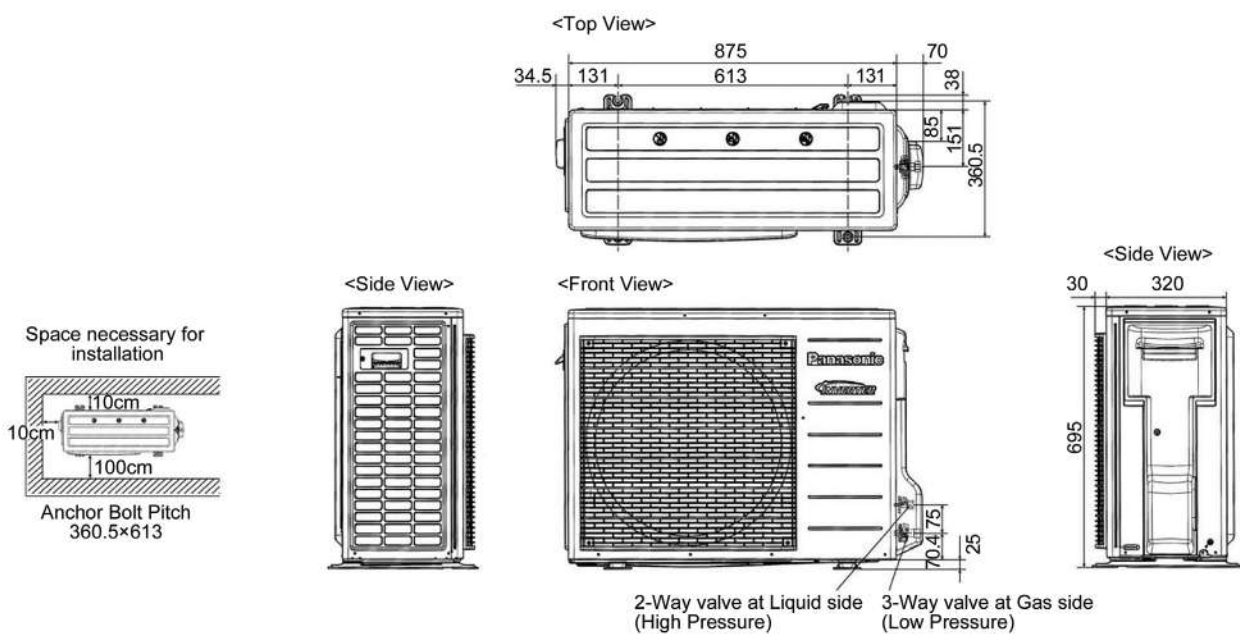

Unit:mm

