

Color Laser Printer Setup Guide

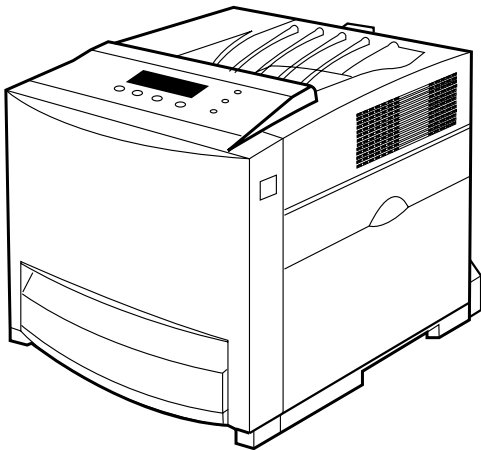

KX-CL500

Model No. **KX-CL510**

Using Manuals:



This manual describes basic setup procedures for the Panasonic KX-CL500/KX-CL510 Color Laser Printer and necessary precautions for safety and use. First read this guide to setup the printer.



For other detailed information, refer to **Operating Instructions** included on the printer CD-ROM*¹, or it is automatically installed on your computer when installing the KX-CL500/KX-CL510 software (see page 17).

If the Acrobat Reader application has not been installed in your computer, it is required to be installed to read the documentation for the printer (see page 22).

*¹ The KX-CL510 printer CD-ROM provided is the Hybrid CD-ROM including both files for Windows®*² and Macintosh. Each files can be displayed in applicable operating system only.

*² Microsoft® Windows® operating system (hereafter Windows)

Please carefully read this manual and keep this documentation in a safe place for future reference.



As an ENERGY STAR® Partner, Panasonic has determined that this product meets the ENERGY STAR® guidelines for energy efficiency. (ENERGY STAR and the ENERGY STAR certification mark are registered US marks.)



Adobe PostScript® 3™

Adobe, the Adobe logo, Acrobat, the Acrobat logo, Adobe Type Manager, ATM, PostScript, PostScript 3 and PostScript 3 logo are either registered trademarks or trademarks of Adobe Systems Incorporated in the United States and/or other countries.

AGFA | Monotype
Font & Imaging Professionals

Scalable type outlines are licensed from Agfa Monotype Corporation. CG, Intellifont, MicroType and Universal Font Scaling Technology (UFST) are trademarks of Agfa Monotype Corporation and may be registered in some jurisdictions.

- Microsoft, Windows and Windows NT are either registered trademarks or trademarks of Microsoft Corporation in the United States and/or other countries.
- Apple, AppleTalk, ColorSync, LaserWriter, Mac, Mac OS, Macintosh and TrueType are trademarks of Apple Computer, Inc.
- Intel, Pentium and Pentium II are trademarks or registered trademarks of Intel Corporation or its subsidiaries in the United States and other countries.
- Avery and all other related brands and product names are trademarks of Avery Dennison Corporation.
- PeerlessPage™ is a trademark of Peerless Systems Corporation.
- PeerlessPrint® and Memory Reduction Technology® are registered trademarks of Peerless Systems Corporation.
- Tornado and VxWorks are registered trademarks of Wind River Systems, Inc.
- All other acknowledgements are trademarks or registered trademarks of their respective holders.

The instructions are subject to change without notice.

Screen shot(s) reprinted with permission from Microsoft Corporation.

Acrobat® Reader® Copyright © 1987-2001 Adobe Systems Incorporated. All rights reserved.
 COPYRIGHT © 2002 Peerless Systems Corporation. All Rights Reserved.
 COPYRIGHT © 2002 Adobe Systems Incorporated. All Rights Reserved.
 Adobe® PostScript® 3™ Copyright © 2002 Adobe Systems Incorporated. All Rights Reserved.
 Copyright © 2002 Wind River Systems, Inc. All right reserved.
 This product contains an implementation of LZW licensed under U.S. Patent 4,558,302.

Copyright © 1998-2002 silex technology, Inc.
 © Matsushita Electric Industrial Co., Ltd. 2003
 © Panasonic Communications Co., Ltd. 2003

Thank you for purchasing the Panasonic KX-CL500 / KX-CL510 Color Laser Printer.

Contents

For Your Safety

General	3
Power Source	3
Laser Safety	3
Ozone Release	3
Moving the Unit	3
Waste Disposal	3
Caution Labels	4

Before You Start

Cautions	6
Part Names	8
Printer Panel	9
System Requirements	10
Minimum Space Requirements	11
Accessories	11
Options and Supplies	12

Setup

Setting up the Printer	13
Connecting the Printer to a Computer	15
Loading Media in the Media Tray	15
Installing the KX-CL500/KX-CL510 Software (For Windows)	17
Installing Applications	22
Installing the KX-CL510 Software (For Macintosh)	22
Using the Manuals	27
Removing the KX-CL500/KX-CL510 Software	28
Power On	29
Setting the LCD Language	29
Printing a Test Page from the Printer Panel	29
Adjusting the Color Density (Color Calibration)	30
Troubleshooting	32

For Your Safety

General

Warning

To prevent fire or shock hazard, do not expose this product to rain or any type of moisture.

Caution

- Do not open covers and do not attempt to repair the unit yourself. Refer servicing to qualified personnel.
- This product uses low frequency electromagnetic fields and may cause harmful interference to sensitive medical implant devices. If you have a cardiac pacemaker or implantable defibrillator, please consult your doctor for additional suggestion or advice.

Power Source

Warning

- The power source voltage of this unit is listed on the nameplate. Only plug the unit into an outlet with the proper voltage.
- When you operate this equipment, the outlet should be near the equipment and accessible.
- To ensure safe operation the AC cord supplied must be inserted into standard three-prong AC outlet which is effectively grounded (earthed) through the normal wiring.
- The fact that the equipment operates satisfactorily does not imply that the power point is grounded (earthed) and that the installation is completely safe. For your safety, if in any doubt about the effective grounding (earthing) of the power point, consult a qualified electrician.
- If the plug cannot be inserted into the AC outlet, contact a licensed electrician to replace the outlet with a properly grounded (earthed) one.
- Do not defeat the purpose of the grounding (earthing) plug (ex. do not use a conversion plug).
- (220-240 V equipment)
A certified power supply cord has to be used with this equipment. The relevant national installation and/or equipment regulations shall be considered. A certified power supply cord not lighter than ordinary polyvinyl chloride flexible cord according to IEC 60227 (designation H05VV-F 3G 1.0 mm²).

Laser Safety

CLASS 1 LASER PRODUCT

Caution

This printer utilizes a laser. Use of controls or adjustments or performance of procedures other than those specified herein may result in hazardous radiation exposure.

Laser diode properties (4 provided)

Laser output	: 5 mW max
Wavelength	: 785 nm
Emission duration	: Continuous

Ozone Release

Warning

Make sure that the printer is installed in a well ventilated room so as not to increase density of ozone in the air. Since ozone is heavier than air, it is recommended that air at floor level be ventilated.

Moving the Unit

The printer weighs approximately 30 kg (66 lbs.). It must be handled by two people. Turn the power off and remove the power cord when handling the unit.

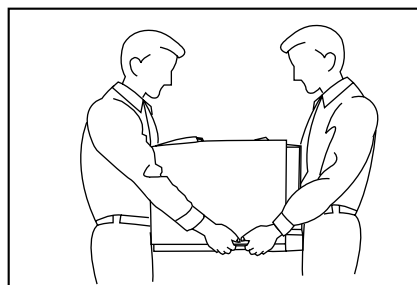

Waste Disposal

Warning

Do not incinerate toner or toner containers. Toner dust may cause flashback when exposed to an open flame.

For Your Safety

Caution Labels

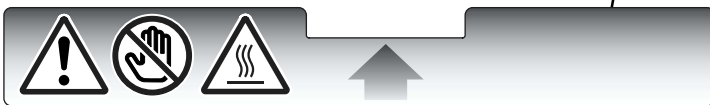
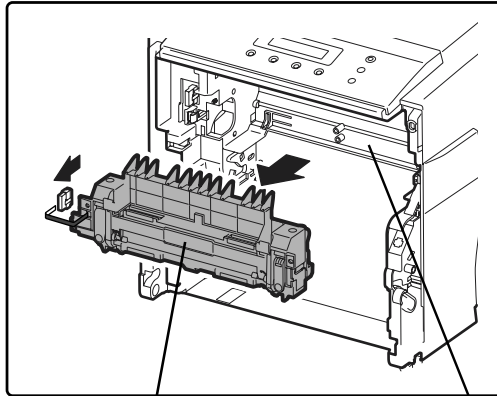

CAUTION
HOT SURFACE
DO NOT TOUCH.



CAUTION
HOT SURFACE
DO NOT TOUCH.

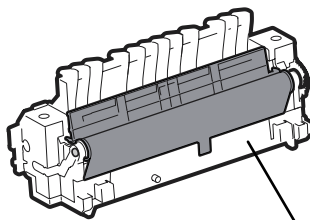



CAUTION
HOT SURFACE
DO NOT TOUCH.

FOR USERS IN U.K.

IMPORTANT: FOR YOUR SAFETY PLEASE READ THE FOLLOWING TEXT CAREFULLY

This printer is supplied with a moulded three pin mains plug for your safety and convenience. A 13 amp fuse is fitted in this plug. Should the fuse need to be replaced please ensure that the replacement fuse has a rating of 13 amps and that it is approved by ASTA or BSI to BS 1362.

Check for the ASTA mark  or the BSI mark  on the body of the fuse.

If the plug contains a removable fuse cover you must ensure that it is refitted when the fuse is replaced.

If you lose the fuse cover the plug must not be used until a replacement cover is obtained.

A replacement fuse cover can be purchased from your local Panasonic Dealer.

IF THE FITTED MOULDED PLUG IS UNSUITABLE FOR THE SOCKET OUTLET IN YOUR HOME THEN THE FUSE SHOULD BE REMOVED AND THE PLUG CUT OFF AND DISPOSED OF SAFELY. THERE IS A DANGER OF SEVERE ELECTRICAL SHOCK IF THE CUT OFF PLUG IS INSERTED INTO ANY 13 AMP SOCKET.

If a new plug is to be fitted please observe the wiring code as shown below.

If in any doubt please consult a qualified electrician.

WARNING: THIS APPLIANCE MUST BE EARTHED.

IMPORTANT: The wires in this mains lead are colored in accordance with the following code.

Green-and-Yellow: Earth Blue: Neutral Brown: Live

As the colors of the wire in the mains lead of this appliance may not correspond with the colored markings identifying the terminals in your plug, proceed as follows.

The wire which is colored GREEN-AND-YELLOW must be connected to the terminal in the plug which is marked with the letter E or by the Earth symbol , or colored GREEN or GREEN-AND-YELLOW.

The wire which is colored BLUE must be connected to the terminal in the plug which is marked with the letter N or colored BLACK.

The wire which is colored BROWN must be connected to the terminal in the plug which is marked with the letter L or colored RED.

How to replace the fuse: Open the fuse compartment with a screwdriver and replace the fuse.

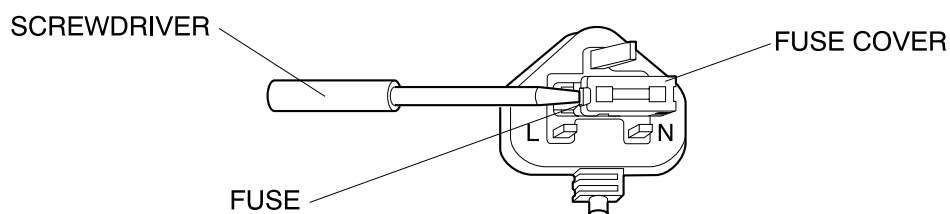

Before You Start

Cautions

To avoid machine malfunction, do not use the equipment under the following conditions:

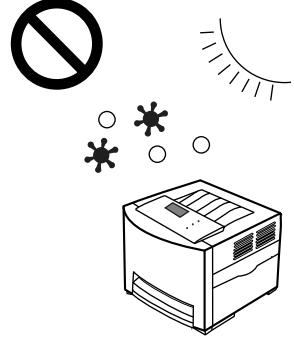
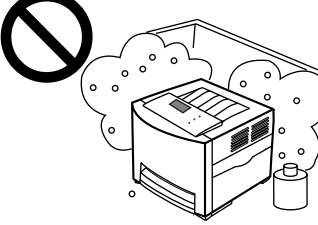
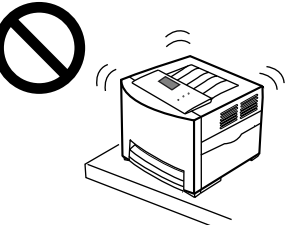
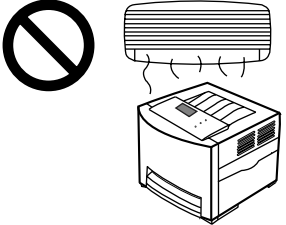
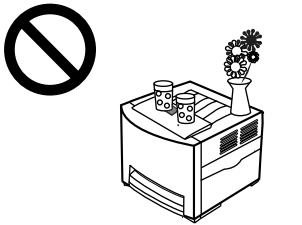
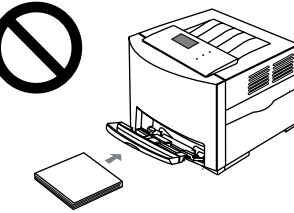
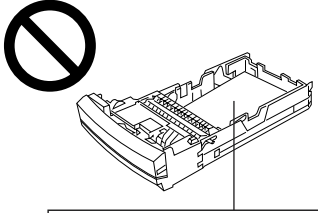
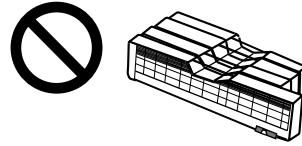
	<ul style="list-style-type: none">• Direct exposure to sunlight.• Extremely high or low temperature [temperature range: 10°C to 32.5°C (50°F to 90.5°F)]• Extremely high or low humidity. (humidity range: 15% to 80% RH)• Condensation due to rapid change of temperature.	 <ul style="list-style-type: none">• Areas of poor ventilation.• Areas of high dust or chemical fume concentration. (solvent etc.)
 <ul style="list-style-type: none">• Unstable or unlevel surfaces.	 <ul style="list-style-type: none">• Directly in front of air conditioning vents.	 <ul style="list-style-type: none">• Liquids near the equipment.
 <ul style="list-style-type: none">• A very large stack of media into the manual feed.	 <p>Media for ink jet (paper, transparency, etc.)</p>	 <p>Not genuine toner</p> <ul style="list-style-type: none">• Any toner other than genuine Panasonic toner; it may damage the printer.

■ Static Electricity Damage

To prevent static electricity damage to any of the following components, touch a grounded metal surface, such as the printer's bare metal frame prior to touching the component.

- Interface connectors: parallel, USB, network, and connector for optional paper feeder
- Connector pins on the optional paper feeder
- Electrical components, connectors inside the printer

■ Interface Cable

Always use a shielded interface cable. Use of an unshielded cable can result in radio interference with data.

■ Power Source

The voltage level of the power source must not vary more than $\pm 10\%$ from the voltage level marked on the nameplate (located on the rear of the unit).

Do not use an extension cord.

Do not use a line conditioner, transient suppressor or surge protector as it may cause a machine error.

■ Ventilation Space

The ventilation space is needed more than 20 mm (0.8") between the printer and a wall.

Before You Start

■ FOR USERS IN UNITED STATES

This equipment has been tested and found to comply with the limits for a Class B digital device, pursuant to Part 15 and 18 of the FCC Rules. These limits are designed to provide reasonable protection against harmful interference in a residential installation.

This equipment generates, uses, and can radiate radio frequency energy and, if not installed and used in accordance with the instructions, may cause harmful interference to radio communications.

However, there is no guarantee that interference will not occur in a particular installation. If this equipment does cause harmful interference to radio or television reception, which can be determined by turning the equipment off and on, the user is encouraged to try to correct the interference by one or more of the following measures:

- Reorient or relocate the receiving antenna.
- Increase the separation between the equipment and receiver.
- Connect the equipment into an outlet on a circuit different from that to which the receiver is connected.
- Consult the dealer or an experienced radio/TV technician for help.

The user may find the booklet "Something About Interference" available from FCC local regional offices helpful.

FCC Warning: To assure continued FCC emission limit compliance, the user must use the recommended shielded interfacing cable when connecting to a host computer. Also, any unauthorized changes or modifications to this equipment would void the user's authority to operate this device.

FCC Declaration of Conformity

Trade Name : Panasonic

Model Number : KX-CL500 or KX-CL510

Responsible Party: Matsushita Electric Corporation of America

One Panasonic Way

Secaucus, NJ 07094 U.S.A.

Telephone No.: 1-800-726-2797

This device complies with Part 15 and 18 of the FCC Rules.

Operation is subject to the following two conditions: (1) This device may not cause harmful interference, and (2) this device must accept any interference received, including interference that may cause undesired operation.

Before You Start

Part Names

Front View

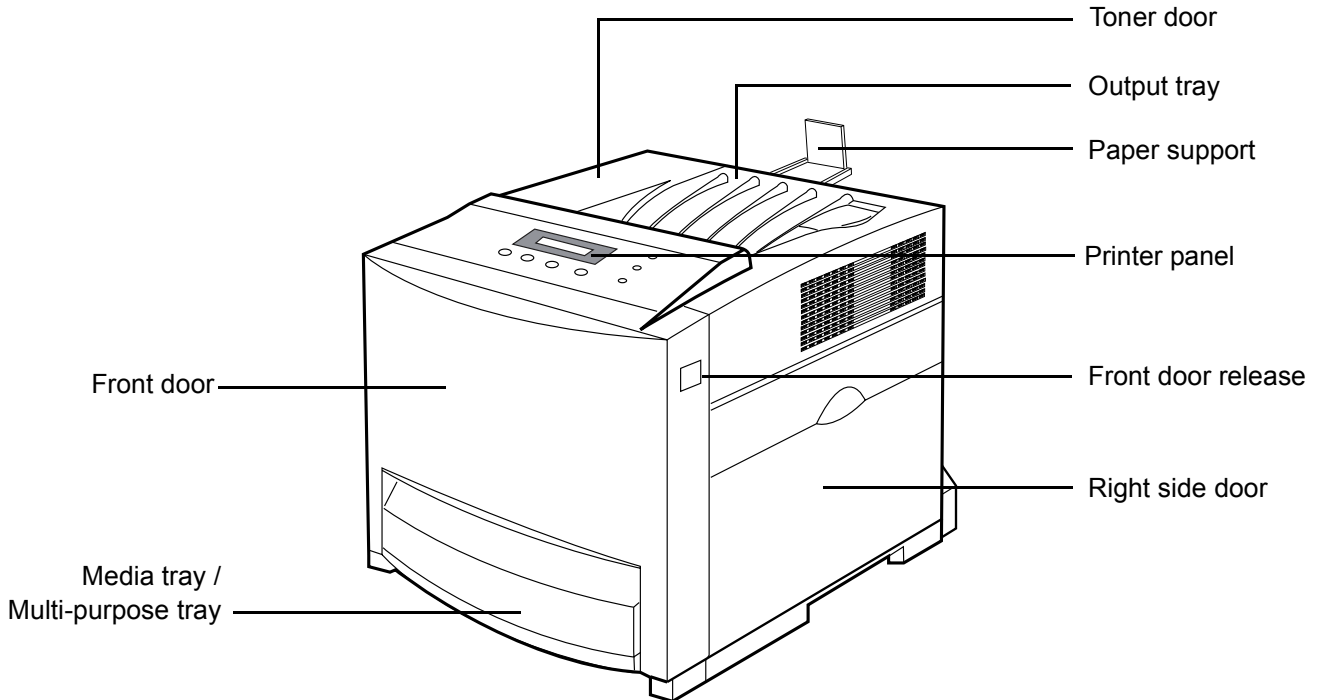

Rear View

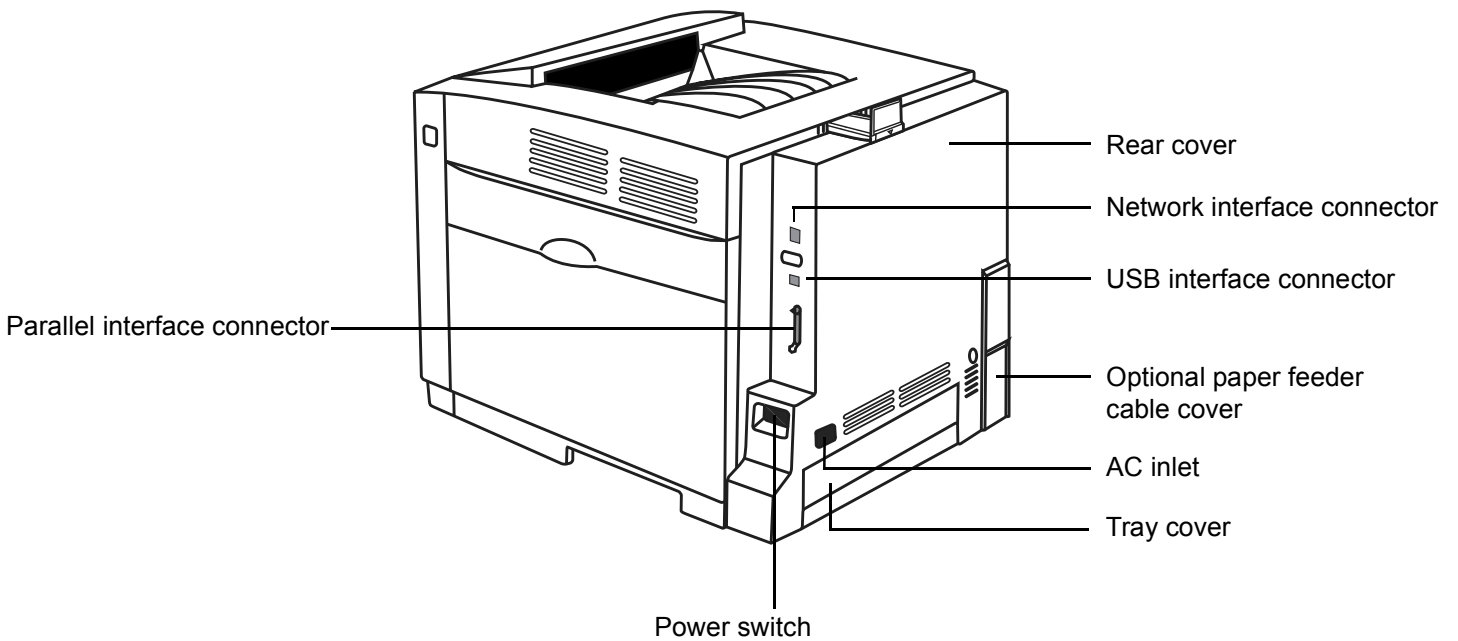

Before You Start

Printer Panel

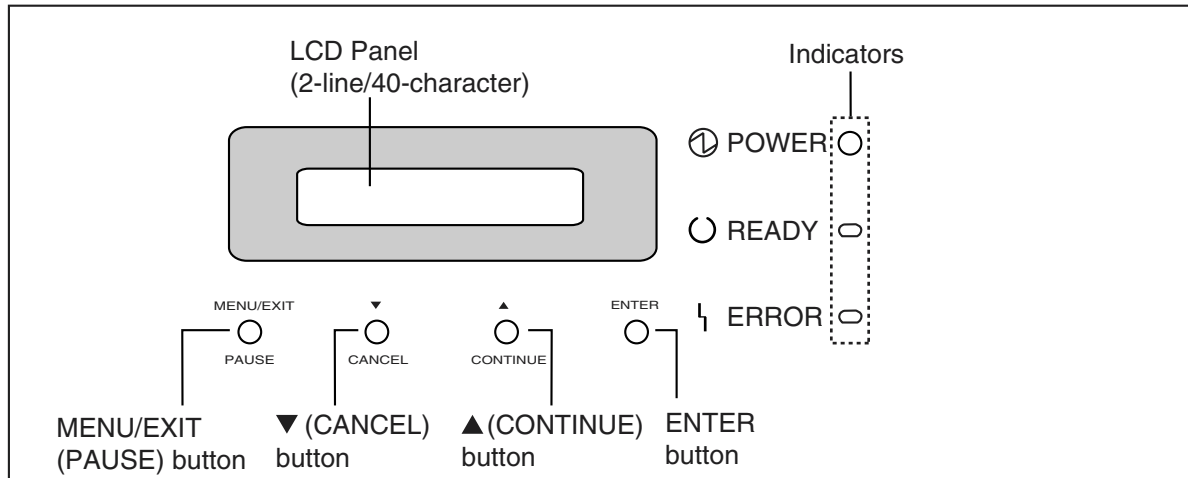

Button Operation

Button	Operation
MENU/EXIT (PAUSE)	In the Menu mode, pressing the MENU/EXIT (PAUSE) button will allow you to exit the Menu mode and Ready is displayed.
	When Processing or Printing is displayed in the upper line of the LCD, pressing the MENU/EXIT (PAUSE) button will allow you to pause printing. While Pause printing is displayed, pressing the MENU/EXIT (PAUSE) button will allow you to resume printing.
▼ (CANCEL)	Displays the previous menu or item.
	Decreases the numerical value of the selection by 1. Hold down this button to scroll faster. While the printer prints, pressing this button will allow you to stop printing or processing the current job.
▲ (CONTINUE)	Displays the next menu or item.
	Increases the numerical value of the selection by 1. Hold down this button to scroll faster. When performing the manual duplex printing function, after even pages are printed, odd pages are printed by pressing this button. When "LOAD XX" appears on the LCD, you can print the current job anyhow by pressing this button.
ENTER	Enters a sub-menu.
	Activates a selection.

Before You Start

Indicators

Three indicators show the following printer's status.

Indicators	Printer Status
Ⓜ POWER ● ○ READY ○ ⌋ ERROR ○	<ul style="list-style-type: none"> Printer is warming up.
Ⓜ POWER ● ○ READY ● ⌋ ERROR ○	<ul style="list-style-type: none"> Printer is ready for printing.
Ⓜ POWER ● ○ READY ⚡ ⌋ ERROR ○	<ul style="list-style-type: none"> Printer is receiving data, printing or data remains in the memory. Printer is in the Menu mode.
Ⓜ POWER ⚡ ○ READY ● ⌋ ERROR ○	<ul style="list-style-type: none"> Printer is in the Power Save mode.
Ⓜ POWER ● ○ READY ○ ⌋ ERROR ⚡	<ul style="list-style-type: none"> Printer recoverable errors (media jam, media empty, etc.) has occurred.
Ⓜ POWER ● ○ READY ○ ⌋ ERROR ●	<ul style="list-style-type: none"> An internal error (Call for Service Error) has occurred.

●, ● Indicator is lit.

○ Indicator is turned off.

⚡, ⚡ Indicator is blinking.

System Requirements

PC

CPU:

Pentium 133 MHz or greater

Operating System:

Windows® 95*¹, Windows® 98*², Windows® Me*³, Windows NT® 4.0*⁴ (Service Pack 3 or later - Service Pack 6 is recommended.), Windows® 2000*⁵, Windows® XP*⁶

Mac OS 8.1, 8.5, 8.6, 9.0, 9.1, 9.2

Mac OS X 10.1, 10.2

RAM:

32 MB or more

NOTE:

- If the system requirement of the operating system is larger than 32 MB, follow it.

Free disk space:

100 MB or more

Drive:

CD-ROM drive

*¹Microsoft® Windows® 95 operating system (hereafter Windows 95)

*²Microsoft® Windows® 98 operating system (hereafter Windows 98)

*³Microsoft® Windows® Millennium Edition operating system (hereafter Windows Me)

*⁴Microsoft® Windows NT® operating system Version 4.0 (hereafter Windows NT 4.0)

*⁵Microsoft® Windows® 2000 operating system (hereafter Windows 2000)

*⁶Microsoft® Windows® XP operating system (hereafter Windows XP)

Before You Start

Minimum Space Requirements

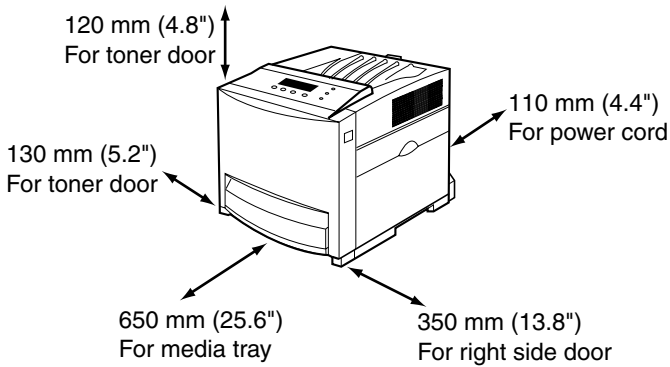

NOTE:

- When you install a consumable component or replace it with new one, additional space may be required.

Accessories

Make sure that all accessories shown below were provided and have not been damaged. Report damage or shortages to the reseller from which the units were purchased. Page 32 includes an area for recording important information such as the name of reseller, serial number, and date of purchase.

NOTE:

- Save the original carton and packing materials for future shipping and transporting of the unit. They have been specifically designed to protect the equipment during shipment.

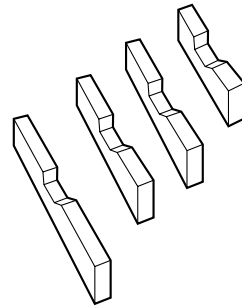

Toner cartridges
(Cyan, Magenta, Yellow, Black)

Printer includes free starter toner cartridges that yield 2,500 pages (based on 5% page coverage per color).

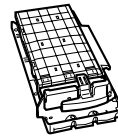

Color print cartridge



Black print cartridge

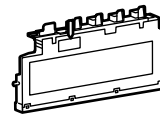

Waste toner cartridge



Power cord



Color calibration card

Keep this Color calibration card for adjusting color density (see page 30).

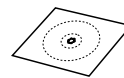

Printer CD-ROM

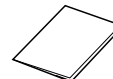

Setup Guide (this manual)



Supplies Re-order Label
(See "Setting the LCD Language" on page 29.)

Before You Start

Options and Supplies

Please contact the reseller from which the printer was purchased when purchasing options or supplies.

Options

Model Number	Description
KX-CLHD1	Hard Disk Drive (10 GB 2.5")
KX-CLPF1	Optional Paper Feeder
KX-CLEM1	128MB DIMM (Optional Memory)
KX-CLAD1	Automatic Duplex Unit
KX-CLUG1	Upgrade Kit (for PostScript 3)

Cautions on Toner Use

CAUTION:

Avoid ingestion, inhalation, eye or skin contact. If ingestion occurs, drink several glasses of water to dilute stomach contents; if inhalation occurs, remove to fresh air; if skin contact occurs, wash thoroughly with soap and water; or if eye contact occurs, flush thoroughly with water.

In all cases, seek medical treatment if adverse symptoms occur.

When the toner cartridge is at the end of its life, do not dispose in fire.

Keep the toner cartridge out of children's reach. Store in a cool and dry place.

BLACK TONER **INGREDIENTS:**
Carbon black (1333-86-4)
Silica (68909-20-6)
Charge control agent (31714-55-3)
Polyester resin (2 kinds)

CYAN TONER **INGREDIENTS:**
MAGENTA TONER Silica (68909-20-6)
YELLOW TONER Charge control agent (72869-85-3)
Polyester resin (2 kinds)
Wax (1 kind)

For USA only
Distributed by Panasonic Digital Document Company
A Unit of Matsushita Electric Corporation of America
Secaucus, NJ 07094

Supplies

Use of supplies other than genuine Panasonic supplies can damage the printer. This will void the warranty of the printer.

Model Number	Description	Average life (pages)* ¹
KX-CLTC1 KX-CLTC1B* ²	Cyan Toner Cartridge	5,000 (5% coverage)
KX-CLTM1 KX-CLTM1B* ²	Magenta Toner Cartridge	5,000 (5% coverage)
KX-CLTY1 KX-CLTY1B* ²	Yellow Toner Cartridge	5,000 (5% coverage)
KX-CLTK1 KX-CLTK1B* ²	Black Toner Cartridge	5,000 (5% coverage)
KX-CLPC1	Color print cartridge	13,000
KX-CLPK1	Black print cartridge	13,000
KX-CLFU1	Fuser Unit	100,000
KX-CLWT1	Waste Toner Cartridge	24,000 (Black and White - 5% coverage) 6,000 (Full color - 5% coverage)
KX-CLAU1	Accumulator Unit	83,000
KX-CLTR1	Transfer Roller	100,000

*¹The rated life expectancy of each consumable is based on printing under specific operating conditions such as page coverage for a particular page size (5% coverage per color at 600 x 600 dpi resolution on letter size paper). The actual consumables life will vary depending on its use and other printing variables including page coverage, page size, media type, print resolution, continuous or intermittent printing, number of color planes, ambient temperature and humidity.

*²For other countries except U.S.A.

Setting up the Printer

Installing the Toner Cartridges

- 1 Open the toner door and remove the sealing tapes.

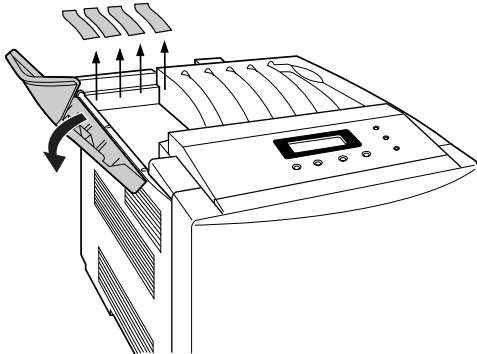

- 2 Open the plastic bags and take out the toner cartridges. Shake the toner cartridges several times.

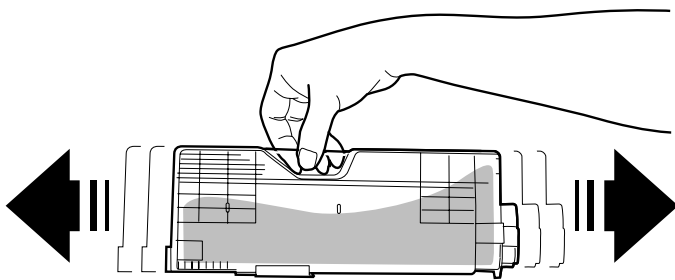

- 3 Insert the toner cartridges in the appropriately labeled slots. From right to left, the order of the color toner cartridges is BLACK (1), CYAN (2), MAGENTA (3), YELLOW (4).

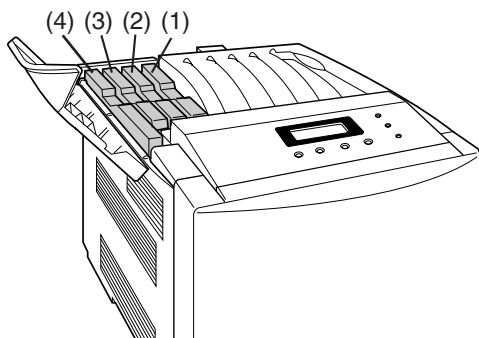
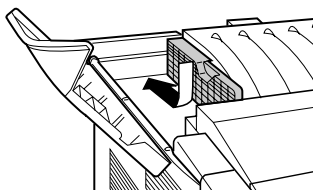

- 4 Close the toner door.

Installing the Print Cartridges

- 1 Open the right side door.

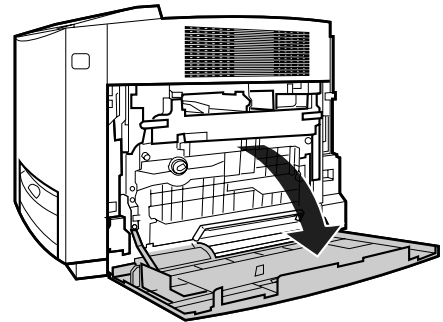

- 2 Unlock and open the print cartridge holder.

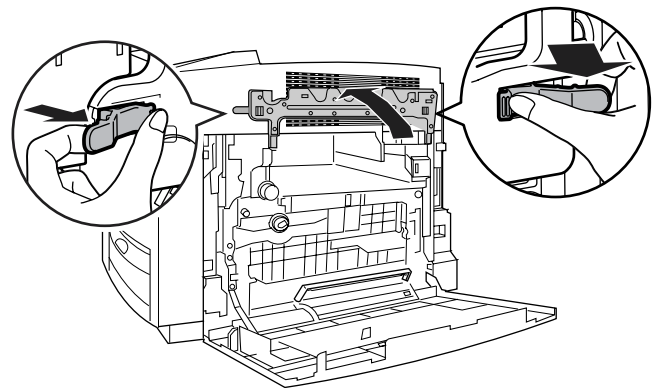

- 3 Open the plastic bags and take out the print cartridges.

- 4 Remove the upper seal covers.

Color print cartridge

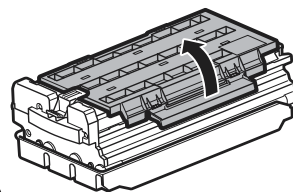

Black print cartridge

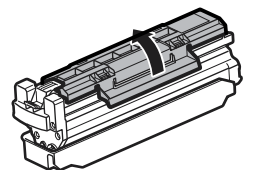

NOTE:

To prevent damage to the print cartridges,

- Do not touch the green drum surface.
- Do not expose to light for more than 45 seconds.
- Do not expose to direct sunlight.

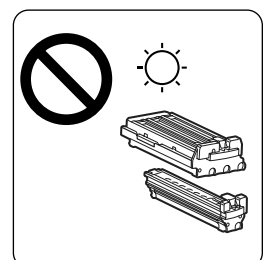
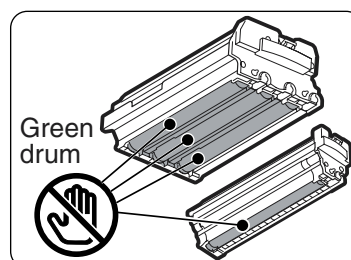

Setup

- 5** Holding the color print cartridge with the protective tray, match the arrow marks (▼) then insert the color print cartridge halfway into the printer.

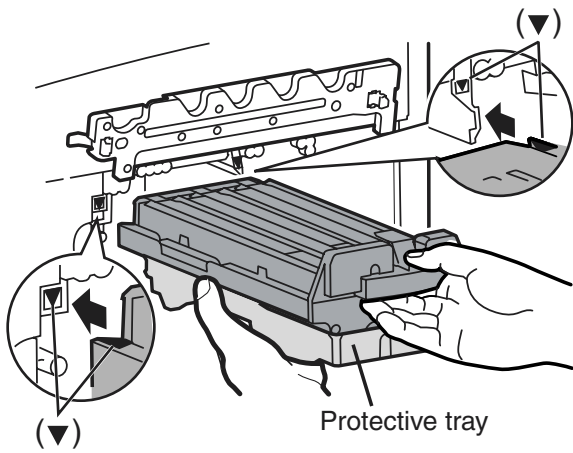

- 6** Firmly push the color print cartridge until it snaps into place.
• Store the protective tray for repacking in future.

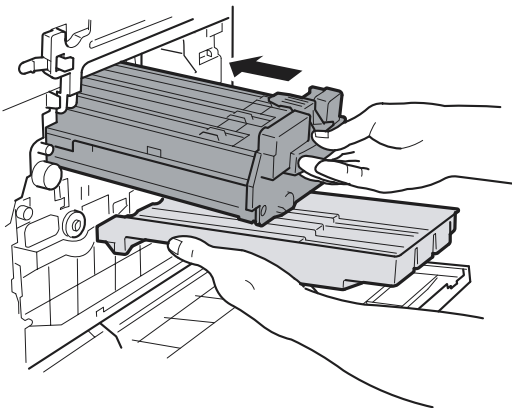

- 7** Repeat Step 4 - 6 for the black print cartridge.

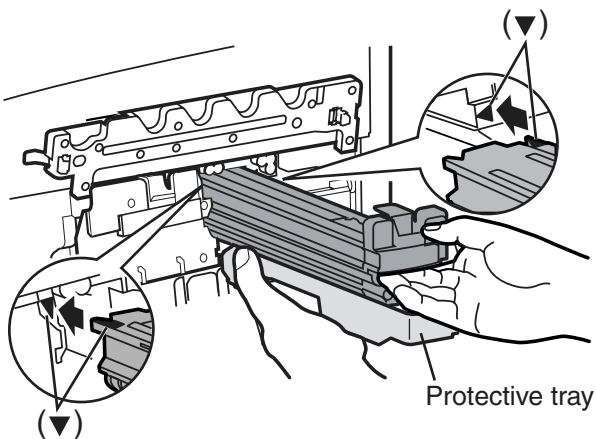

- 8** Install the waste toner cartridge (1) and slide the green lever (2) to the left.

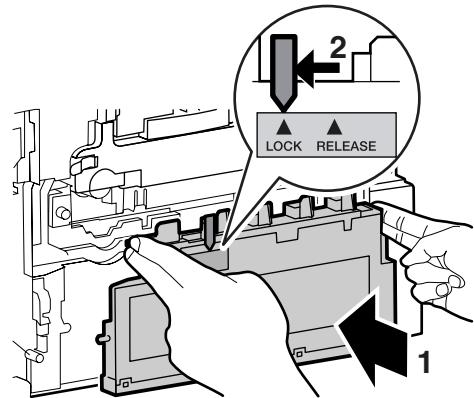

- 9** Close the print cartridge holder until it clicks and locks it.

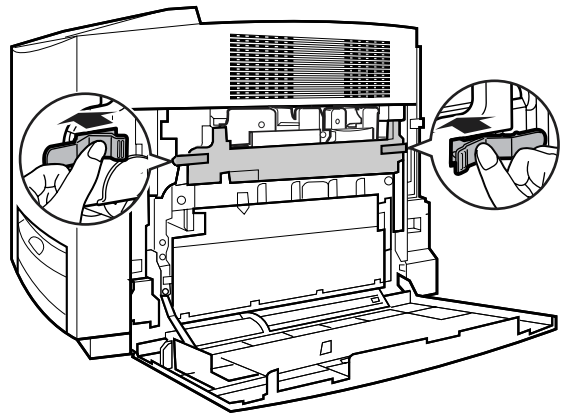

- 10** Close the right side door.

Connecting the Printer to a Computer

NOTE:

- If you do not have a (Bidirectional) parallel interface cable or USB cable, you may need to purchase one.

(A) When using a parallel interface cable:

NOTE:

- Use a shielded cable 2.0 m (6.6 ft.) or less in length.

(B) When using the USB interface cable:

NOTE:

- Use a shielded cable 5.0 m (16.4 ft.) or less in length.
- Windows 98, Windows Me, Windows 2000, Windows XP, Mac OS 8.6, 9.0, 9.1, 9.2 or Mac OS X 10.1, 10.2 is required for a USB connection.

(C) When using the network interface cable:

NOTE:

- Use category 5 shielded twisted pair cable with RJ-45 connectors.
- Do not connect other connectors than 100Base-TX / 10Base-T. Excessive current flow may cause damage of the unit.

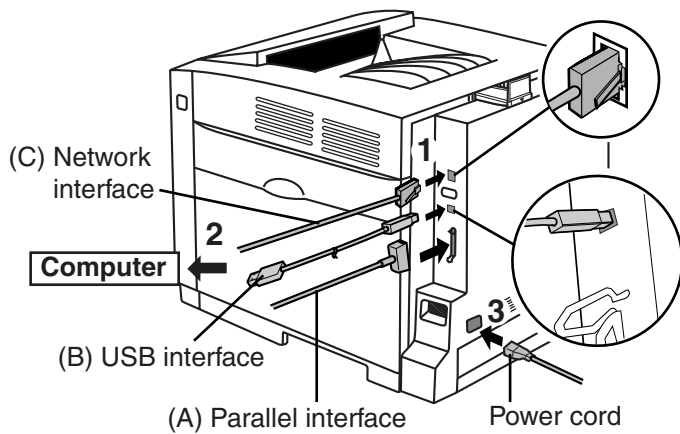

- 1 Connect the interface cable to the printer.
- 2 Connect the other end of the interface cable to the computer.
- 3 Connect the power cord to the printer.

Loading Media in the Media Tray

Media Type	Media Weight	Media Size
Plain paper Bond/Letterhead Recycled paper	75 -105 g/m ² (20 -28 lb.)	Letter, Legal, A4, B5 (JIS)
Thin paper	60 -75 g/m ² (16 - 20 lb.)	

- 1 Pull the media tray (1) out of the printer while slightly raising its front portion and remove the tray pad (2).

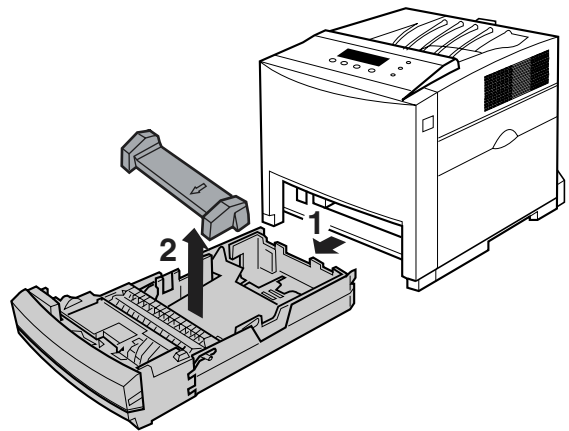

CAUTION:

- Be sure to hold the media tray with both hands so you do not drop it.

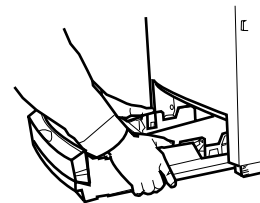

NOTE:

- When the tray cover is opened or the multi-purpose tray is used, you cannot pull the media tray out of the printer. Be sure to push the multi-purpose tray and close the tray cover before you pull the media tray out of the printer or open the front door.

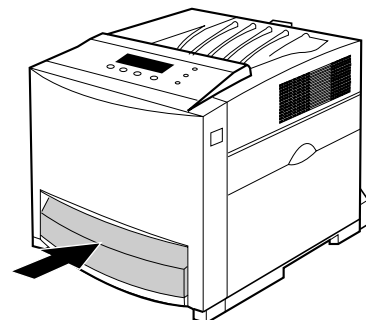

Setup

- 2 Pinch the media guides and slide them to the width of the media.

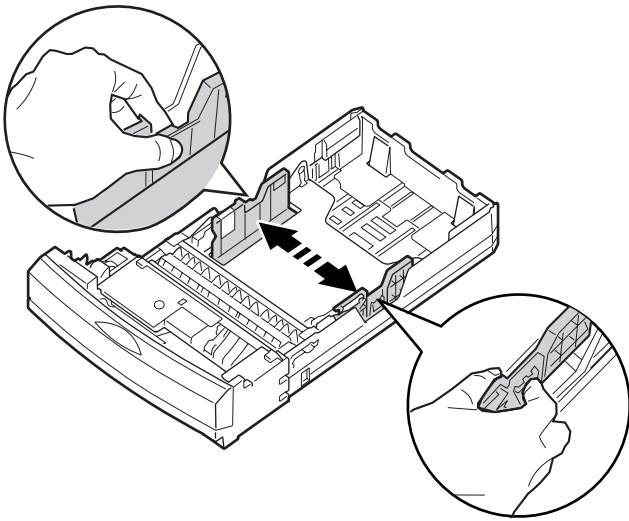

- 3 Slide the length guide unit to adjust it to the media length. Slide the length guide unit (2) while pressing the **PUSH** mark (1) to extend it.

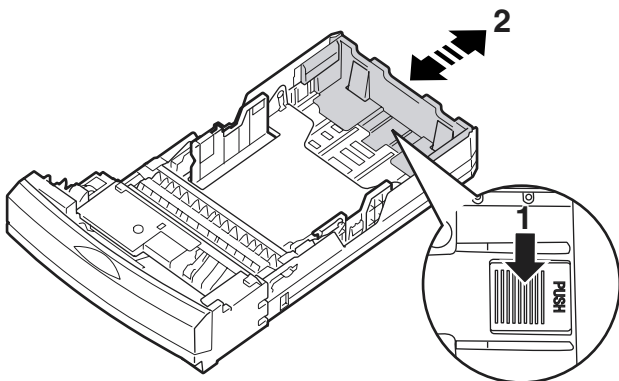

- 4 Tap the media stack on a level surface to avoid media jams or skewed printing.

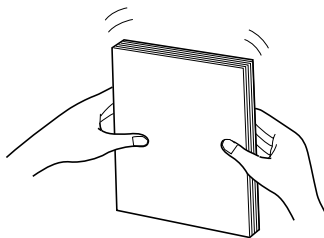

NOTE:

- Be careful not to leave fingerprints on the media, which can result in a smudged print.
- Reusing media (used paper or jammed paper) that has been fed through the printer once can reduce the life of the consumables and paper path components.

- 5 Place media with the **print side up** under the hooks in the tray.

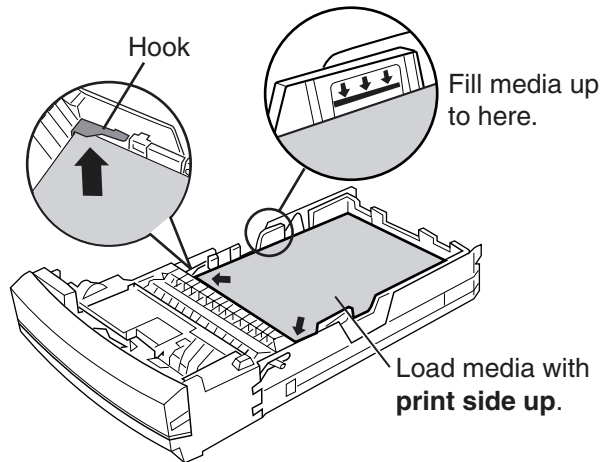

NOTE:

- Coated Paper, Transparencies or Envelopes can be loaded in the multi-purpose tray. See “About Media” of “Setting and Printing” in the Operating Instructions.
- Most media has instructions recommending the side to be printed first.
- Do not mix different types or thickness of media in the media tray at one time; this may cause a jam.
- Loading media exceeding the designated sheets may cause a media jam or shifting of print.

- 6 Confirm the media guides are adjusted to the media size.

- 7 Slide the media tray completely into the slot.

CAUTION

- Be sure to hold the media tray with both hands so that you do not drop it. The media tray weighs approximately 6.4 kg (14 lbs.) when it is fully loaded.

- 8 Pull (1) and raise (2) the paper support so that the media does not drop from the output tray.

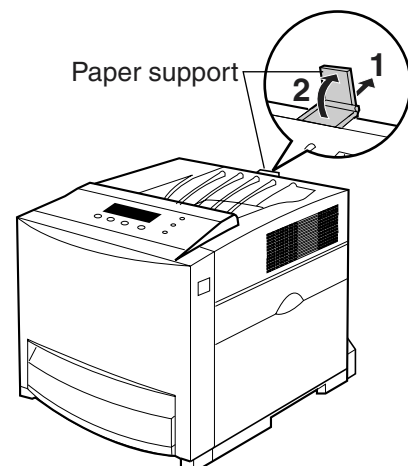

Installing the KX-CL500/ KX-CL510 Software (For Windows)

There are two methods of installing printer software for Windows, **Automated Printer Setup** and **Custom Printer Setup**. This Setup Guide only explains the **Automated Printer Setup**. If you want to use the **Custom Printer Setup**, refer to Network section of the Operating Instructions.

Printer Software	Automated Printer Setup	
	KX-CL500	KX-CL510
PCL 5c Printer Driver	✓	✓
PS Printer Driver	–	✓
LPR Port Monitor	✓	✓
Status Display	✓	✓
HDD Utility (It is installed when a hard disk drive option is installed in the printer.)	✓	✓
Print Media Test Pattern*1	–	–
Operating Instructions	✓	✓

✓: It is automatically installed.

*1It can be installed using the Custom Printer Setup.

When using the Network Interface Cable:

The following are the steps to set up LPR Port printing using TCP/IP.

Step 1: Setting up TCP/IP on the computer

Step 2: Setting up TCP/IP on the printer

Step 3: Installing the printer driver and utilities

Step 1: Setting up TCP/IP on the computer

If the TCP/IP protocol is already installed on your computer and it is configured, proceed to the next step. If it is not installed, you need to install TCP/IP in the operating system on the computer and configure it. If the administrator manages the IP Address, contact him/her to confirm the values before setting up. Be sure to assign the unique value for the IP Address that is not used on another device on the network. Regarding the configuration of TCP/IP, refer to the help menu or documentation for Windows.

Step 2: Setting up TCP/IP on the printer

You need to set the IP Address, Subnet Mask and Default Gateway for the printer. It can be set by using one of the following three methods.

- Using the DHCP server
- Using the Network Setup Tool
- Using the Printer Panel

If the administrator manages the network with DHCP server, it will automatically assign an IP Address, Subnet Mask and Default Gateway. These can be viewed by printing out the configuration page (see below).

For the instructions of another method, refer to “Network” section in the Operating Instructions (see “Using the Manuals” on page 27).

- 1 Turn the printer **on** (see “Power On” on page 29).
- 2 Press **MENU/EXIT (PAUSE)** button on the printer panel.
- 3 Press **▲ (CONTINUE)** button until **Test Page** menu appears.
- 4 Press **ENTER** button.
Menu Map item menu appears.
- 5 Press **▲ (CONTINUE)** button until **Configuration Page** item menu appears.
- 6 Press **ENTER** button.
The configuration page will be printed.
- 7 Confirm the IP Address on the configuration page.

NOTE:

- If the printer receives the IP Address with unlimited lease term, the printer keeps the address permanently. The printer saves the address statically and the DHCP function becomes disable automatically.

Step 3: Installing the printer driver and utilities

If you want to install the printer driver and utilities using the network interface cable, be sure to connect the printer with a network interface cable and to turn it on in advance. Perform the following steps to complete the installation.

For Windows NT 4.0, Windows 2000, Windows XP

- Log in as an Administrator.

For Windows NT 4.0

- Confirm the LPR port is installed. (Refer to Network section of the Operating Instructions.)
- (1) Click **Custom Printer Setup**.
 - (2) Click **Install Network Port**.
 - (3) Insert the Windows NT 4.0 CD-ROM and install the Microsoft TCP/IP Printing Service.

Setup

- 1 Insert the printer CD-ROM disk into the CD-ROM drive.
The CD-ROM launches automatically.



NOTE:

- If the CD-ROM does not launch automatically, perform the following steps (1) - (2).
 - (1) Double click **My computer** icon.
 - (2) Double click the CD-ROM icon.

- 2 Click **Automated Printer Setup**.
- 3 If the **Purchase Information** window*¹ is displayed, select the shop where you purchased the printer and click **[Next >]**.
 - If you cannot find the shop where you purchased the printer, select **Other** and click **[Next >]**.
The **License Agreement** window is displayed.

*¹ Displayed depending on the country.

- 4 Click **[Yes]**.
The **Select Printer** window is displayed.
- 5 Select the printer of the IP Address confirmed on the Configuration Page at Step 2.
- 6 Click **[Next >]**.
The **Installed Device** window is displayed.

NOTE:

- The installed devices are already detected and checked.

- 7 Click **[Next >]**.
This wizard starts installing the Printer Driver and Utilities.
The **InstallShield Wizard Complete** window is displayed.
- 8 Click **[Finish]**.
The printer driver is installed after restarting Windows. (For Windows NT 4.0, Windows 2000, Windows XP, you must log on the computer as an Administrator.)

When using the Parallel Interface Cable

When you install the printer driver and utilities using the parallel interface cable, be sure to turn off the printer or not to connect the printer with a parallel interface cable to avoid the Plug and Play installation.

Perform the following steps to complete the installation, then turn the printer on (see "Power On" on page 29).

- 1 Insert the printer CD-ROM disk into the CD-ROM drive.
The CD-ROM launches automatically.

NOTE:

- If the CD-ROM does not launch automatically, perform the following steps (1) - (2).
 - (1) Double click **My computer** icon.
 - (2) Double click the CD-ROM icon.

- 2 Click **Automated Printer Setup**.
- 3 If the **Purchase Information** window is displayed, select the shop where you purchased the printer and click **[Next >]**.
 - If you cannot find the shop where you purchased the printer, select **Other** and click **[Next >]**.
The **License Agreement** window is displayed.
- 4 Click **[Yes]**.
The **Select Printer** window is displayed.

NOTE:

- If you cannot find the printer on your network, the **Warning** message will be displayed. Click **[OK]** to continue.

- 5 Click on the **Choose the current port myself (LPT / USB)** check button and click **[Next >]**.
The **Select Printer Port** window is displayed.
- 6 Click on the LPT port (Ex. LPT1:) and click **[Next >]**.
The **Installed Device** window is displayed.
- 7 Click on the check box of the installed options in your printer, then Click **[Next >]**.
The Setup program starts installing the Printer Driver and Utilities.
The **InstallShield Wizard Complete** window is displayed.
- 8 Click **[Finish]**.

Setup

NOTE:

For Windows XP

- If the Found New Hardware Wizard window is displayed during restarting Windows after installing the printer driver, perform the following instructions.

- (1) Select **Install the software automatically [Recommended]** in the Found New Hardware Wizard window and click **[Next >]**.
- (2) Select **Printer Driver** and click **[Next >]**.
- (3) Click **[Continue Anyway]**.
- (4) Click **[OK]**.
The Files Needed window is displayed.
- (5) Click **[Browse...]** and select
PCL folder [D (CD-ROM drive letter):\WinXP \ ENGLISH \ PCL or
PS folder [D (CD-ROM drive letter):\WinXP \ ENGLISH \ PS].
- (6) Follow the instructions on the screen.

When using the USB Interface Cable (for Windows 98 / Windows Me / Windows 2000 / Windows XP):

When you connect the printer and the computer using a USB interface cable, turn off the printer to avoid the Plug and Play installation.

- 1** Start Windows.
- 2** Quit all applications.
- 3** Insert the printer CD-ROM disk into the CD-ROM drive.
- 4** Exit the **Panasonic Setup** window to setup the USB port first.
- 5** Turn the printer **on** (see "Power On" on page 29).
The **Wizard** window appears. Go to the following step depending on the operating system.
 - step 6-A for Windows 98.
 - step 6-B for Windows Me.
 - step 6-C for Windows 2000.
 - step 6-D for Windows XP.

NOTE:

- When using the printer and other USB device simultaneously, we cannot guarantee normal printing.
- For Windows 98 and Windows Me, restarting of the computer may be required.

6-A (For Windows 98)

- (1) Click **[Next >]**.

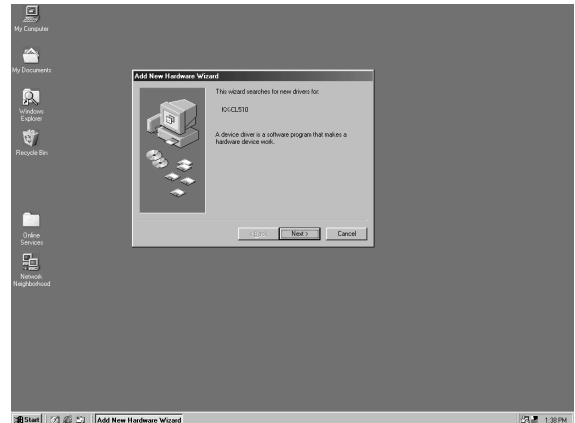

- (2) Click on the **Search for the best driver for your device [Recommended]** check button and click **[Next >]**.



- (3) Click on the **Specify a location** check box, then click **[Browse...]**.
- (4) Select **Win98** folder [D (CD-ROM drive letter):\Usb\Win98], then click **[OK]**.
- (5) Click **[Next >]** until **[Finish]** window is displayed.
- (6) Click **[Finish]**.
- (7) Click **[Next >]**.
- (8) Click on the **Search for the best driver for your device [Recommended]** check button and click **[Next >]**.
- (9) Click on the **Specify a location** check box, then click **[Browse...]**.
- (10) Select **Pcl** folder [D (CD-ROM drive letter):\Win9x\English\Pcl] or **Ps** folder [D (CD-ROM drive letter):\Win9x\English\Ps], then click **[OK]**.
- (11) Click **[Next >]**.
- (12) Click **[Next >]**.
- (13) Follow the instructions on the screen.
- (14) Proceed to step **7** on page 21.

Setup

6-B (For Windows Me)

- (1) Click on the **Specify the location of the driver (Advanced)** check button and click **[Next>]**.

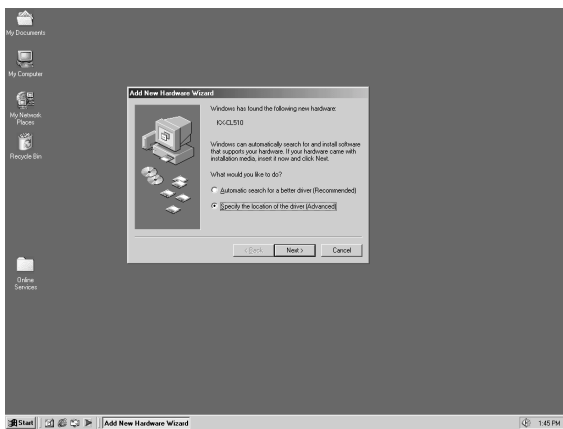

- (2) Click on the **Search for the best drive for your device(Recommended)** check button and **Specify a location** check box and click **[Browse]**.



- (3) Select **WINME** folder [D (CD-ROM drive letter):\USB\WINME] and click **[OK]**.
- (4) Click **[Next>]** until **[Finish]** window is displayed.
- (5) Click **[Finish]**.
- (6) Click on the **Specify the location of the driver (Advanced)** check button and click **[Next>]**.
- (7) Click on the **Search for the best drive for your device(Recommended)** check button and **Specify a location** check box and click **[Browse]**.
- (8) Select **PCL** folder [D (CD-ROM drive letter):\WINME\ENGLISH\PCL] or **PS** folder [D (CD-ROM drive letter):\WINME\ENGLISH\PS], then click **[OK]**.
- (9) Click **[Next>]**.
- (10) Click **[Next>]**.
- (11) Follow the instructions on the screen.
- (12) Proceed to step 7 on page 21.

6-C (For Windows 2000)

- (1) Click **[Next>]**.

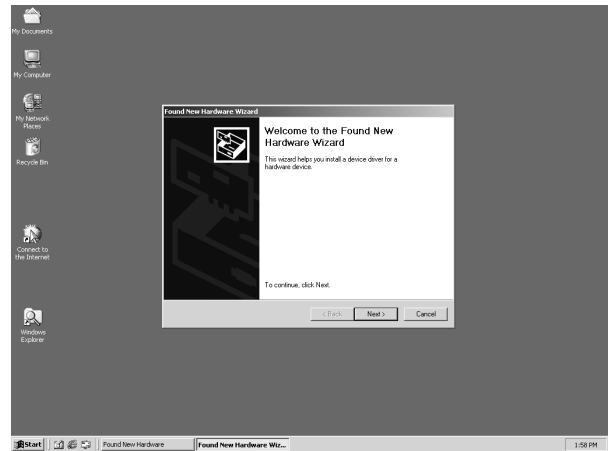

- (2) Click on the **Search for a suitable driver for my device(recommended)** check button and click **[Next>]**.



- (3) Confirm the **Specify a location** is checked and click **[Next>]**.
- (4) Click **[Browse...]** and select **PCL** folder [D (CD-ROM drive letter):\Win2000\ENGLISH\PCL] or **PS** folder [D (CD-ROM drive letter):\Win2000\ENGLISH\PS]. Click **[Open]**. Click **[OK]**.
- (5) Click **[Next>]**.
- (6) If the Digital Signature Not Found window is displayed, click **[Yes]**.
- (7) Click **[Finish]**.
- (8) Proceed to step 7 on page 21.

6-D (For Windows XP)

- (1) Click on the **Install from a list or specific location (Advanced)** check button and click **[Next>]**.



- (2) Click on the **Search for the best driver in these locations** check button and **Include this location in the search** check box and remove the check mark of the **Search removable media (floppy, CD-ROM...)** check box and click **[Browse]**.

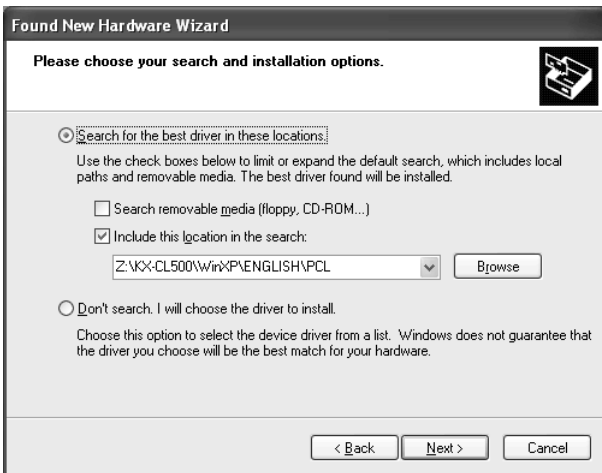

- (3) Select **PCL** folder [D (CD-ROM drive letter):\WinXP\ENGLISH\PCL] or **PS** folder [D (CD-ROM drive letter):\WinXP\ENGLISH\PS]. Click **[OK]**.
- (4) Click **[Next>]**.
- (5) If the Hardware Installation window is displayed, click **[Continue Anyway]**.
- (6) Click **[Finish]**.
- (7) Proceed to step 7 on page 21.

- 7 To install utilities software, double click **My computer** icon, then double click the drive (example D:) for CD-ROM.

The **Panasonic Setup** window is displayed.

- 8 Click **Automated Printer Setup**.

- 9 If the **Purchase Information** window is displayed, select the shop where you purchased the printer and click **[Next >]**.

- If you cannot find the shop where you purchased the printer, select **Other** and click **[Next >]**.

The **License Agreement** window is displayed.

- 10 Click **[Yes]**.

The **Select Printer** window is displayed.

NOTE:

- If you cannot find the printer on your network, the **Warning** message will be displayed. Click **[OK]** to continue.

- 11 Click on the **Choose the current port myself (LPT / USB)** check button and click **[Next>]**.

The **Select Printer Port** window is displayed.

- 12 Click on the USB port (Ex. USB001) and click **[Next >]**.

The **Installed Device** window is displayed.

- 13 Click on check box of the installed options in your printer, then click **[Next >]**.

The Installer starts installing the Printer Driver and Utilities by this condition.

Follow the instruction on the screen to complete the installation.

The **InstallShield Wizard Complete** window is displayed.

- 14 Click **[Finish]**.

Installing Applications

Application	KX-CL500	KX-CL510
Adobe Acrobat Reader 5.0*1	✓	✓
Remote Maintenance Setting Tool	✓	✓
Web Administrative Tool*2	✓	✓
Adobe Type Manager 4.1	–	✓

✓: It can be installed.

*1 File name of Acrobat Reader may differ depending on the version.

*2 Only available in Windows NT 4.0, Windows 2000 or Windows XP Professional.

To install the desired application:

- 1 Insert the printer CD-ROM disk into the CD-ROM drive.
The CD-ROM launches automatically.
- 2 Click the **Install Applications**.
- 3 Click the desired applications above.
- 4 Follow the instructions on the screen to complete the installation.

NOTE:

- Web Administrative Tool enables the ability to manage the device connected to the network. For the installation and usage, see Readme as follows.

- (1) Double click the **Readme.txt** in the printer CD-ROM disk [D (CD-ROM drive letter): \Network\WebTool\English\Readme.txt].
- (2) See the System requirements. (To install the Web Administrative Tool, Web server is required. Refer to the help menu of Windows to install the Web server.)

- When using Adobe Type Manager, install it by following “To install the desired application:” (select “Adobe Type Manager 4.1” at step 3).

This application does not include fonts. If you use ATM fonts, double click the **PS3FONT.EXE** in the printer CD-ROM disk to extract the ATM fonts. PS3FONT.EXE is in the Fonts folder [D (CD-ROM drive letter):\ ATM \ Fonts].

Installing the KX-CL510 Software (For Macintosh)

Install the KX-CL510 Software following the steps below.

1. **Installing the PPD file (and Printer Driver)**
(see below)
2. **Setting the Computer (and Printer)**
(see page 23)
3. **Installing the Additional Software (For Mac OS 8.1 - Mac OS 9.2)**
(see page 27)

Installing the PPD File (and Printer Driver)

For Mac OS 8.1 - Mac OS 9.2

Step 1: Installing the KX-CL510 PPD file and utilities

Install the KX-CL510 PPD (PostScript Printer Description) file, and then install the Adobe PostScript printer driver.

- 1 Insert the **KX-CL510 CD-ROM** disk in your CD-ROM drive, and then double-click the **KX-CL510** icon, the **Mac OS** folder and the **English** folder.
- 2 Double-click the **KX-CL510 Installer** icon.
The **END-USER LICENSE AGREEMENT** window is displayed.
- 3 Click **[Continue]**.
The **KX-CL510 Installer** window is displayed.
- 4 Click **Easy Install** and select **Custom Install**.
- 5 If you find the shop where you purchased the printer, click on its check box.
Or
If you cannot find the shop where you purchased the printer, select **Easy Install** from the Installation type.
- 6 Change the Install Location if you need to, then click **[Install]**.
The installation starts.
The “Installation was successful” window will be displayed after finishing installation.
- 7 Follow the instruction on the screen to complete the installation.

NOTE:

- The Easy Install installs the KX-CL510 printer description file, USB printer class driver, ColorSync profile and Status Display.
If you want to install the additional software “KX-Printer Network Setup Tool”, select Custom Install to complete the installation.
- The Status Display folder is created in the (Macintosh HD:Panasonic:KX-CL510) folder after finishing installation successfully.
If you install the “KX-Printer Network Setup Tool” using the Custom Install, its folder is also created in the same folder.

Step 2: Installing the Adobe PostScript printer driver

- 1** Insert the **KX-CL510 CD-ROM** disk in your CD-ROM drive, and then double-click the **KX-CL510** icon, the **Mac OS** folder and the **English** folder.
- 2** Double-click the **AdobePS Installer** icon in accordance with the Macintosh OS version.
 - AdobePS 8.7.2 Installer: Mac OS 8.6 / 9.0 / 9.1 / 9.2
 - AdobePS 8.6 Installer: Mac OS 8.1 / 8.5The **Adobe PostScript Driver** window is displayed.
- 3** Click **[Continue...]**.
The **License** window is displayed.
- 4** Click **[Accept]** to proceed this installation.
The **AdobePS Installer** window is displayed.
- 5** Click **[Install]**.
The installation starts.
The “Installation was successful” will be displayed after finishing installation.
- 6** Follow the instruction on the screen to complete the installation.

NOTE:

- For best results any job sent to the printer should be sent using the Adobe driver and the KX-CL510 PPD. Provide the installer to all users who send jobs.

For Mac OS X 10.1 - Mac OS X 10.2

Step 1: Installing the KX-CL510 PPD (PostScript Printer Description) file and ColorSync profile

- 1** Insert the **KX-CL510 CD-ROM** disk in your CD-ROM drive, and then double-click the **KX-CL510** icon, **Mac OS X, English** folder.
- 2** Double click the **KX-CL510Install** icon.
- 3** Follow the instructions to complete the installation.

NOTE:

- If you want to print Classic application documents, you are required to install the KX-CL510 software for Mac OS 9.2, then set the computer and printer. Refer to “For Mac OS 8.1-Mac OS 9.2” in this section.

Setting the Computer (and Printer)

Set the computer (and printer) depending on the interface: **network** (see below) or **USB** (see page 25).

■ When using the Network Interface Cable

The following are the steps to set up network printing using AppleTalk and TCP/IP.

- Step 1: Setting up AppleTalk and TCP/IP on the computer**
- Step 2: Setting up TCP/IP on the printer**
- Step 3: Setting the PostScript printer driver**

Step 1: Setting up AppleTalk and TCP/IP on the computer

If the AppleTalk and TCP/IP of your computer are already set, proceed to the next step. If they are not set, consult with your network administrator. Regarding the configuration of TCP/IP, refer to the help menu or documentation for Macintosh.

NOTE:

- Refer to “Network” section in the Operating Instructions about setting the AppleTalk and TCP/IP to your Macintosh.

Setup

Step 2: Setting up TCP/IP on the printer

You need to set the IP Address, Subnet Mask and Default Gateway for the printer. It can be set by using one of the following three methods.

- Using the DHCP server
- Using the KX-Printer Network Setup Tool
- Using the Printer Panel

If the administrator manages the network with DHCP server, it will automatically assign an IP Address, Subnet Mask and Default Gateway. These can be viewed by printing out the configuration page (see below).

For the instructions of another method, refer to "Network" section in the Operating Instructions (see "Using the Manuals" on page 27).

- 1** Turn the printer **on** (see "Power On" on page 29).
- 2** Press **MENU/EXIT (PAUSE)** button on the printer panel.
- 3** Press **▲ (CONTINUE)** button until **Test Page** menu appears.
- 4** Press **ENTER** button.
Menu Map item menu appears.
- 5** Press **▲ (CONTINUE)** button until **Configuration Page** item menu appears.
- 6** Press **ENTER** button.
The configuration page will be printed.
- 7** Confirm the IP Address and MAC Address on the configuration page.

Step 3: Setting the PostScript printer driver

For Mac OS 8.1 - Mac OS 9.2

If you want to select the KX-CL510 in Chooser, be sure the printer is connected to the network and turn it on in advance. Perform the following steps to select the KX-CL510 printer.

- 1** Select **Chooser** from the **Apple** menu.
- 2** Confirm AppleTalk is active.
- 3** Click the **AdobePS** printer icon in the **Chooser**.
- 4** Select the correct AppleTalk zone if necessary.
- 5** Select the AppleTalk name **KX-CL510-XXXXXX** from the "Select a PostScript Printer:" scroll list. XXXXXX indicates the last 3 byte of MAC address of the printer network interface. You can obtain the number (hexadecimal six digits) from the label near the network interface connector or by printing a configuration page.
If an icon is not appeared on the left of the printer name you selected, follow the instructions below.
(1) Click **[Create]**.
(2) Confirm that an icon appears to the left of the printer name.
The KX-CL510 desktop printer icon is created on your desktop screen.
- 6** Close the **Chooser**.

For Mac OS X 10.1 - Mac OS X 10.2

Before you can use a printer, you must add it in the Print Center. If you want to select the KX-CL510 in the Print Center, be sure the printer is connected to the network and turned it on in advance (see "Power On" on page 29). KX-CL510 appears in the Print Center by choosing AppleTalk as the connection type. Perform the following steps to select the KX-CL510 printer.

NOTE:

- Log on the computer as an Administrator.
- The Print Center is in the Utilities folder (Macintosh HD: Applications:Utilities).

- 1** Open the **Print Center**.
- 2** Select **Add Printer...** from the **Printers** menu.
- 3** Choose **AppleTalk** as the connection type, and click **KX-CL510-XXXXXX**.
KX-CL510-XXXXXX is displayed in the Printer List. XXXXXX indicates the last 3 byte of MAC address of the printer network interface. You can obtain the number (hexadecimal six digits) from the label near the network interface connector or by printing a configuration page.
- 4** Confirm the Printer Model is set to **Auto Select...** and click **Add**.
- 5** Close the **Print Center**.

■ When using the USB Interface Cable

For Mac OS 8.6 - Mac OS 9.2

Step 1: Setting the PostScript printer driver

When you connect the printer and your Macintosh using a USB interface cable and turn the printer on (see "Power On" on page 29), KX-CL510 appears in the "Select a USB Printer:" list of the Desktop Printer Utility.

- 1** Start the **Desktop Printer Utility**.
(Macintosh HD:AdobePS Components:Desktop Printer Utility)
The **New Desktop Printer** window is displayed.
- 2** Select **AdobePS** from the **With** menu.
- 3** Select **Printer (USB)** from the **Create Desktop** list, and click **[OK]**.
The **Untitled 1** window is displayed.
- 4** Click **[Change...]** button in the **USB Printer Selection** group.
The **USB Printer** window is displayed.
- 5** Select **KX-CL510** from the "Select a USB Printer:" list, then click **[OK]**.
- 6** Click **[Auto Setup]**.
The "Panasonic KX-CL510.PPD" is displayed in the "PostScript™ Printer Description (PPD) File".
- 7** Click **[Create...]**.
The confirmation window is displayed.
- 8** Click **[Save]**.
- 9** Be sure to edit "**KX-CL510USB**" in the "Save desktop printer as:", then click **[Save]**.
The KX-CL510USB desktop printer icon is created on your desktop screen.

Step 2: Setting the KX-CL510 to the Default Printer:

- 1** Click the **KX-CL510USB** desktop printer icon.
- 2** Click **Printing** menu and select **Set Default Printer**.

For Mac OS X 10.1

Step 1: Setting the PostScript printer driver

Before you can use a printer, you must add it in the Print Center. If you want to select the KX-CL510 in the Print Center, be sure you connect the printer and your Macintosh using a USB interface cable and turn the printer on (see "Power On" on page 29). KX-CL510 appears in the Print Center by choosing USB as the connection type. Perform the following steps to select the KX-CL510 printer.

NOTE:

- The Print Center is in the Utilities folder (Macintosh HD: Applications:Utilities).

- 1** Open the **Print Center** and choose **Add Printer...** from the **Printers** menu.
- 2** Choose **USB** as the connection type, and click **KX-CL510**.
- 3** Confirm the Printer Model is set to **Auto Select...** and click **Add**.
- 4** Close the **Print Center**.

Step 2: Setting the KX-CL510 to the Default Printer

- 1** Open the **Print Center** and click **KX-CL510**.
- 2** Select **Make Default** from the **Printers** menu.
- 3** Close the **Print Center**.

NOTE:

- When you add a printer in the Print Center, the new printer becomes the default printer.

For Mac OS X 10.2

Step 1: Setting the PostScript printer driver

The printer is automatically added in the Print Center if the printer is connected to a computer and turned on (see "Power On" on page 29). Change the printer's PPD file from Generic to the specific one as follows.

NOTE:

- The Print Center is in the Utilities folder (Macintosh HD: Applications:Utilities).

- 1** Open the **Print Center** and click **KX-CL510**.
- 2** Select **Show Info** from the **Printers** menu.
- 3** Click **Name & Location** and select **PPD** or **Printer Model**.
- 4** Click **Generic PostScript Printer** and select **Panasonic**.
- 5** Click **Panasonic KX-CL510** from the **Model Name** list, and click **[Apply Changes]**.
- 6** Close the **Print Center**.

Step 2: Setting the KX-CL510 to the Default Printer

- 1** Open the **Print Center** and click **KX-CL510**.
- 2** Select **Make Default** from the **Printers** menu.
- 3** Close the **Print Center**.

NOTE:

- When you add a printer in the Print Center, the new printer becomes the default printer.
- Selection menus may be changed depending on the version of the operating system.

Installing the Additional Software (For Mac OS 8.1 - Mac OS 9.2)

Additional software, including Adobe Type Manager, and PostScript screen fonts are included on the KX-CL510 CD-ROM. Copy fonts files from PS3 Fonts folder on the KX-CL510 CD-ROM to the System Folder of your Macintosh hard drive. Note that font files need to be moved to specific locations (Fonts folder of the System Folder); others can be moved to a folder of your choice.

Adobe Type Manager

Adobe Type Manager (ATM) is included on the KX-CL510 CD-ROM. Adobe Type Manager (hereafter ATM) can be installed by using the installer in the ATM folder. This application can be used to transfer Type 1 fonts to the printer's memory or hard disk drive, or to manage fonts on the printer.

Manual downloading of fonts not already provided on the printer eliminates the need for automatic downloading of fonts used by a document, which speeds printing. You can also:

- Improve the screen display of PostScript fonts

PostScript and TrueType fonts

In addition to PostScript Type 1 fonts, TrueType fonts are included in the PS3 Fonts folder on the KX-CL510 CD-ROM.

ATM cannot be used to install TrueType fonts. These fonts can, however, be installed by dragging a copy of each from the PS3 Fonts folder on the KX-CL510 CD-ROM to your System folder.

Using the Manuals

To read the Operating Instructions, Acrobat Reader must be installed in your computer.

For Windows

■ Installing the Acrobat Reader

To install the Acrobat Reader, see "Installing Applications" on page 22.

■ Reading the Operating Instructions using the printer CD-ROM

- 1** Insert the printer CD-ROM disk into the CD-ROM drive.
The CD-ROM launches automatically.
- 2** Click **O/I Manual**.

■ Reading the Operating Instructions from the Start menu

- 1** Click **Start**, move the pointer to **Programs**, **Panasonic**, **Panasonic KX-CL500** or **Panasonic KX-CL510**, and **Manual**.
- 2** Click **Operating Instructions**.

Setup

For Macintosh

The following files are included on the KX-CL510 CD-ROM:

Setup.pdf	Setup Guide
Contents.pdf Print.pdf Mainte.pdf Network.pdf	Operating Instructions
Reader Installer	Acrobat Reader Installer

To open and read a manual on your computer screen, install Acrobat Reader for Macintosh in your computer.

■ Installing the Acrobat Reader:

- 1 Insert the **KX-CL510 CD-ROM** disk in your CD-ROM drive, and then double-click the **KX-CL510** icon.
- 2 Open the **Manual** folder, then the **English** folder.
- 3 Double-click the **Reader Installer** icon.
- 4 Follow the instructions on the screen to install the Acrobat Reader program.

■ Opening a Manual's File:

- 1 Perform step 1 to 2 of "Installing the Acrobat Reader".
- 2 Double-click a manual's file name (**Setup.pdf** or **Contents.pdf**) that you want to read.

The first page of the manual will be displayed on your computer screen.

Refer to the Help of the Acrobat Reader for details on its operation.

Removing the KX-CL500/ KX-CL510 Software

If you need to remove the KX-CL500/KX-CL510 software, perform the following steps.

For Windows

- 1 Click **[Start]**, move the pointer to **Programs**, **Panasonic**, and **Panasonic KX-CL500** or **Panasonic KX-CL510**.
- 2 Click **Uninstall Driver and Utilities**.
- 3 Select **Remove** check button and click **[Next>]**.
- 4 Follow the instructions on the screen.
- 5 After uninstalling, restart your computer.

For Macintosh

For Mac OS 8.1 - Mac OS 9.2

- 1 Open the **KX-CL510 Installer Log File**.
(Macintosh HD: KX-CL510 Installer Log File)
- 2 After confirming each location of installed files, remove them manually.
- 3 Remove the **KX-CL510** desktop printer icon.

NOTE:

- If you are not familiar with the Macintosh computer, you only have to remove the **KX-CL510** folder. (Macintosh HD:Panasonic:KX-CL510)

For Mac OS X 10.1 - Mac OS X 10.2

- 1 Remove the ColorSync profile **CL510PS.icc**.
(Macintosh HD:Library:ColorSync:Profiles:CL510PS.icc)
- 2 Remove the PostScript Printer Description file **Panasonic KX-CL510.PPD**.
(Macintosh HD:Library:Printers:PPDs:Contents:Resources:en.lproj:Panasonic KX-CL510.PPD)
- 3 Click the printer (KX-CL510 or KX-CL510-XXXXXX) to be removed in the printer list of the **Print Center**, and then click **Delete (Delete Printer)** from the **Printers** menu.

NOTE:

- If the KX-CL510 software for Mac OS 9.2 is installed, remove it (refer to "For Mac OS 8.1 - Mac OS 9.2").

Power On

Turn the printer on, then the computer.
The READY indicator on the printer starts blinking.
After approximately 30 seconds [Standard Memory without the printer's hard disk drive at 20°C (68°F) / 65%RH / 120V], "Ready" is displayed on the printer LCD panel.

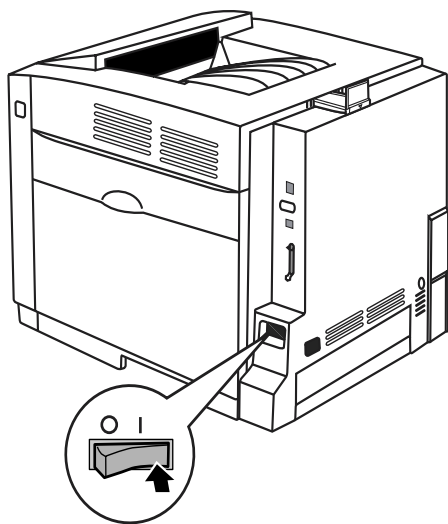

NOTE:

- If the Self Calibration is done, it will take much time.
- When the printer enters the Power Save mode, the POWER indicator will start blinking and "Power Save" will be displayed on the printer LCD panel.
- When you turn on the printer for the first time, it will take about 5 minutes to fill the printer with toner. When the process is completed, the printer's LCD will display "Ready".

Setting the LCD Language

- Select English, German, French, Spanish or Italian as the language which is to appear on the LCD panel.
- English is the default language.

- 1 Press **MENU/EXIT (PAUSE)** button to enter the Menu mode.
- 2 Press **▲ (CONTINUE)** or **▼ (CANCEL)** button until the **Other** menu appears.
- 3 Press **ENTER** button.
Language item menu appears.
- 4 Press **ENTER** button.
English selection menu appears.
- 5 Press **▲ (CONTINUE)** or **▼ (CANCEL)** button until the desired language is displayed.
- 6 Press **ENTER** button to activate your selection.

NOTE:

- Adhere the enclosed "Supplies Re-order Label" near the printer's LCD panel to assist you in interpreting the supplies related messages that may appear on the printer's LCD display.

Printing a Test Page from the Printer Panel

It is possible to confirm the printer's settings by printing a configuration page.

- 1 Press **MENU/EXIT (PAUSE)** button to enter the Menu mode.
- 2 Press **▲ (CONTINUE)** button until **Test Page** menu appears.
- 3 Press **ENTER** button.
Menu Map item menu appears.
- 4 Press **▲ (CONTINUE)** button until **Configuration Page** item menu appears.
- 5 Press **ENTER** button.
The printer will start printing a configuration page.

Adjusting the Color Density (Color Calibration)

The printer panel provides an interface to adjust the density of the toner applied to the media. This feature compensates for the changes that can occur as environmental conditions change, replacement of accumulator unit and/or print cartridge.

Perform the following steps to adjust the color density:

1. Print a Color Calibration Test Print Page to confirm the current density (Color Calibration) and compare it with the provided Color Calibration Card.
2. If you wish to adjust the density for all colors simultaneously, proceed to **“Adjusting the Density for All Colors Simultaneously”**.
OR
If you wish to adjust the density for each color independently, proceed to **“Adjusting the Density for Each Color Independently”**.

Printing a Color Calibration Test Print Page

- 1 Press **MENU/EXIT (PAUSE)** button on the printer panel.
- 2 Press **▲ (CONTINUE)** button until **Color Calibration** menu is displayed.
- 3 Press **ENTER** button.
Calibration Offset item menu appears.
- 4 Press **▲ (CONTINUE)** button until **Calib. Test Prn.** menu is displayed.
- 5 Press **ENTER** button.
A Color Calibration Test Print Page will be printed.
 - The current density setting for each color is indicated by the line enclosure on the Color Calibration Test Print Page as shown in the following example.

Color Calibration Test Print Page (Example):

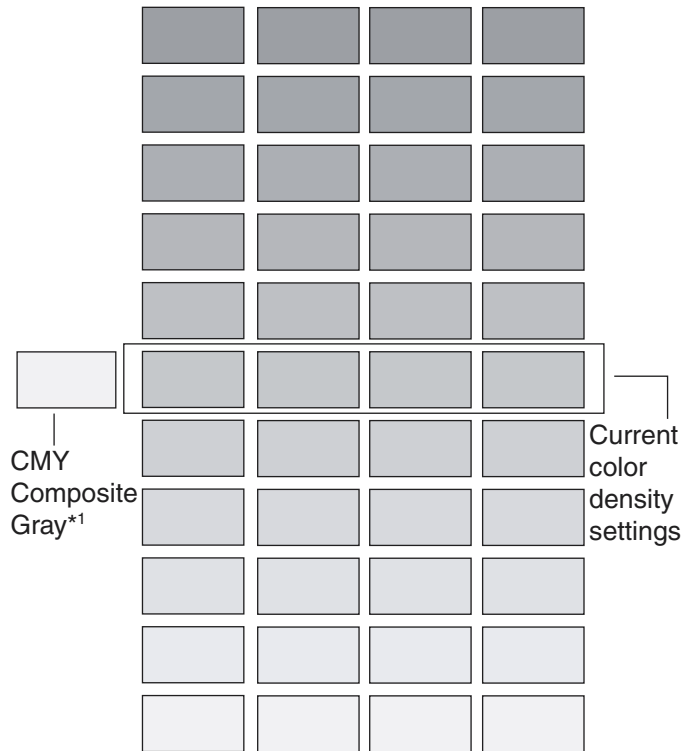

*1 CMY Composite Gray is the color mixed CYAN, MAGENTA and YELLOW. If the color calibration is proper, the CMY Composite Gray is near gray.

- 6 Compare the current color density settings on the Color Calibration Test Print Page with the color density samples on the Color Calibration Card to see if they match.
 - Place the Color Calibration Test Print Page on at least 2 sheets of clean white paper in a well-lighted area.

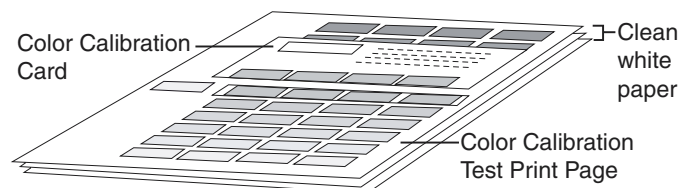

- If they match and CMY Composite Gray is proper, then you do not need to adjust the color density and you may proceed with any operation you wish to perform.
 - If they do not match, go to the next step.
- 7 Determine which block on the Color Calibration Test Print Page most closely matches the density of the cyan sample on the Color Calibration Card.
 - Repeat this step for each color.
 - 8 Proceed to **“Adjusting the Density for All Colors Simultaneously”** or **“Adjusting the Density for Each Color Independently”**.

Adjusting the Density for All Colors Simultaneously

- 1 Press **MENU/EXIT (PAUSE)** button on the printer panel.
- 2 Press **▲ (CONTINUE)** button until **Color Calibration** menu is displayed.
- 3 Press **ENTER** button.
Calibration Offset item menu appears.
- 4 Press **ENTER** button.
0* (-5 to 5) selection menu appears.
- 5 Press **▲ (CONTINUE)** or **▼ (CANCEL)** button to darken/lighten for all the colors to match with the colors of the Color Calibration Card.
To make the color density setting of the Color Calibration Test Print Page darker or lighter by 1 level, increase or decrease a value of the Calibration Offset by 1 by pressing **▲ (CONTINUE)** or **▼ (CANCEL)** button.

For example, when Calibration Offset is 0:
 - If you wish to make the density setting **darker by 1 level**: Select **1** by pressing **▲ (CONTINUE)** button once.
 - If you wish to make the density setting **lighter by 1 level**: Select **-1** by pressing **▼ (CANCEL)** button once.
- 6 Press **ENTER** button.
CYAN item menu appears.
- 7 Press **▲ (CONTINUE)** or **▼ (CANCEL)** button until **Calib. Test Prn.** menu is displayed.
- 8 Press **ENTER** button to reprint the Color Calibration Test Print Page.
 - The line enclosure and Gray Balance reflects the changes made to the settings.
 - If you are not satisfied with the current color density settings, repeat the above steps.

Adjusting the Density for Each Color Independently

- 1 Press **MENU/EXIT (PAUSE)** button on the printer panel.
- 2 Press **▲ (CONTINUE)** button until **Color Calibration** menu is displayed.
- 3 Press **ENTER** button.
Calibration Offset item menu appears.
- 4 Press **▲ (CONTINUE)** button.
CYAN item menu appears.
- 5 Press **ENTER** button.
0* (-5 to 5) selection menu appears.
- 6 Press **▲ (CONTINUE)** or **▼ (CANCEL)** button to darken/lighten the cyan color to match with the cyan color of the Color Calibration Card.
To make the color density setting of the Color Calibration Test Page darker or lighter by 1 level, increase or decrease a value of the CYAN density by 1 by pressing **▲ (CONTINUE)** or **▼ (CANCEL)** button.

For example, when the CYAN density is 0:
 - If you wish to make the density setting **darker by 1 level**: Select **1** by pressing **▲ (CONTINUE)** button once.
 - If you wish to make the density setting **lighter by 1 level**: Select **-1** by pressing **▼ (CANCEL)** button once.
- 7 Press **ENTER** button.
- 8 Repeat steps 5 through 7 for each color (MAGENTA, YELLOW, BLACK).
 - To skip a color, press **▲ (CONTINUE)** button.
 - To return to a previous color, press **▼ (CANCEL)** button.
 - Before going to step 9, make sure **Calib. Test Prn.** item menu is displayed.
- 9 Press **ENTER** button to reprint the Color Calibration Test Print Page.
 - The line enclosure and Gray Balance reflects the changes made to the settings.
 - If you are not satisfied with the current color density settings, repeat the above steps.

NOTE:

- Changes made using Color Calibration are retained until the color density is adjusted next time.
- The color density setting affects the average life of toner.

Troubleshooting

For the detailed information, refer to the "Maintenance and Specifications" section of the Operating Instructions.

FOR USERS IN UNITED STATES

Technical Support Calls

If you have read this manual and tried the troubleshooting procedures and you are still having difficulty, please contact the reseller from which the unit was purchased. You may also call the end user technical support telephone number which is operational during East Coast business hours (9:00 AM to 5:00 PM).

The end user technical support number is 1-800-PANASYS.

This number is available within the U.S. only.

The serial number is located on the label on the rear of the unit. For your convenience, record the number below and keep this book along with your proof of purchase, in the event of a theft or for future reference.

MODEL NO. _____

NAME OF RESELLER _____

SERIAL NO. _____

DATE OF PURCHASE _____

Panasonic Digital Document Company A Unit of Matsushita Electric Corporation of America

Two Panasonic Way, Secaucus, New Jersey 07094

Panasonic Sales Company (PSC) Division of Matsushita Electric of Puerto Rico, Inc.

Ave. 65 de Infateria, Km. 9.5, San Gabriel Industrial Park Carolina, Puerto Rico 00985

Panasonic Canada Inc.

5770 Ambler Drive, Mississauga, Ontario, L4W 2T3

Web Site : <http://www.panasonic.ca/>

Matsushita Electric Industrial Co., Ltd.

Web Site : <http://www.panasonic.co.jp/global/>

World Wide Web Support : <http://panasonic.co.jp/pcc/products/en/printer/>