

Kích thước

1 Dàn lạnh

1.1 CS-N9ZKH-8 / CS-N12ZKH-8

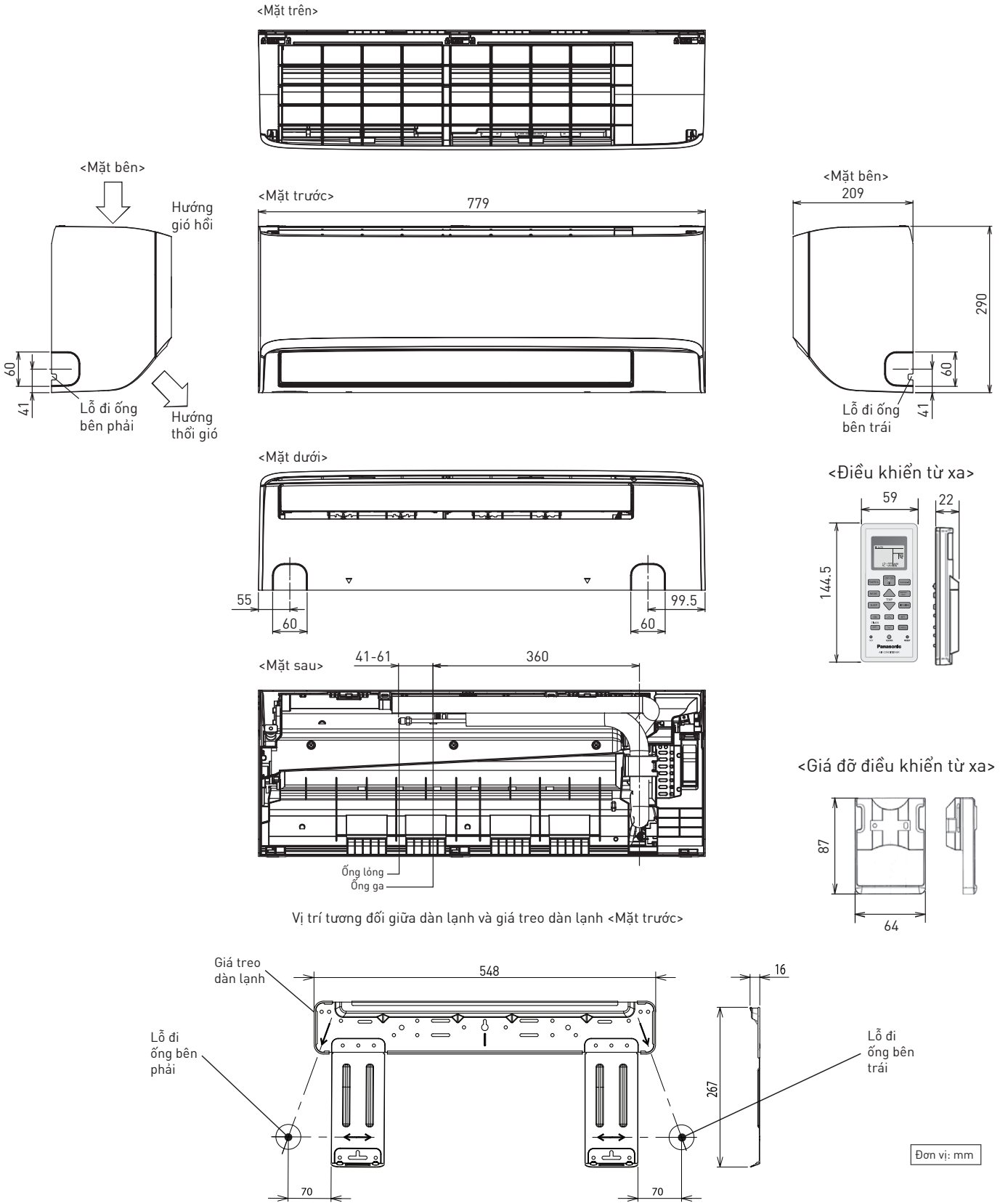

2 Dàn nóng

2.1 CU-N9ZKH-8 / CU-N12ZKH-8

