

WALL MOUNT VENTILATING FAN

FV-25AUF1

Filter Series



- Perforated aluminum filter for oil capture
- Filter with hydrophobic coating allows easy clean
- Large capacity oil cup with oil level indicator
- Condenser motor with thermal cutoff
- Well lubricated ball bearing for long life operation
- Automatic shutter
- Powerful exhaust under actual usage condition (20 Pa)

Dimension

Unit : mm

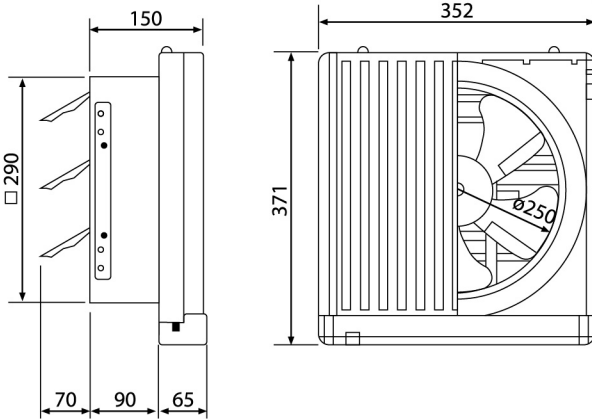

Performance Data

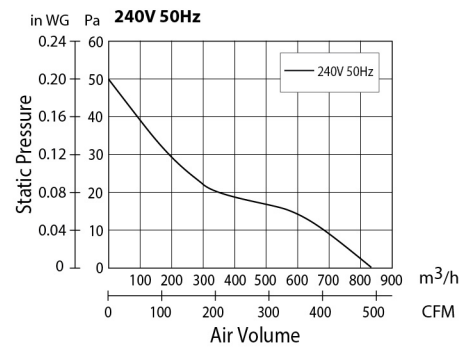
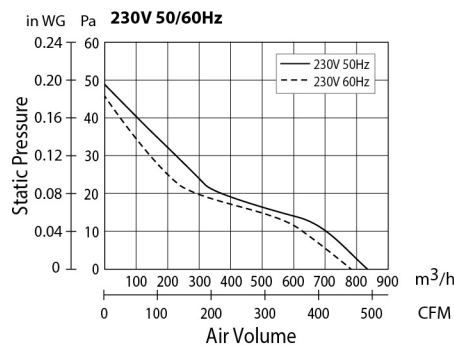
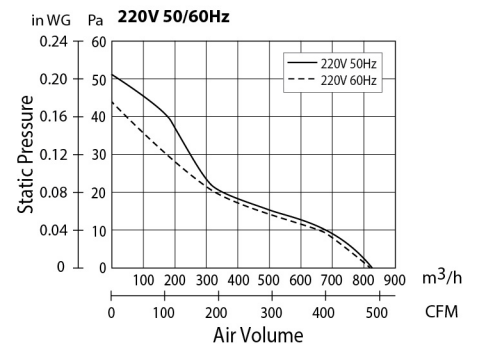

Specification

Model No.	Voltage		Air Volume		Consumption	RPM	Noise	Weight	Installation Space
	[V]	[Hz]	[m³/h]	[CFM]					
FV-25AUF1	220	50	835	491	34	1,100	42	2.8	300 x 300
		60	820	483	34	1,060	42		
	230	50	790	465	31	1,050	41		
		240	50	835	491	34	1,100		

Note : RPM data is for reference only, values may vary subject to different conditions

Test Condition

- Air volume, electric characteristic and noise are specified at the static pressure of 0 Pa
- The values of noise level is A weighted average sound pressure level, the mean value are measured by our company, within +3 to -7 dB tolerance
- The values of noise level are measured at 1 m apart from the side of fan body
- The values of air volume are the mid-points of results measured by our company, within ±10% tolerance