

WALL MOUNT VENTILATING FAN



FV-20AL9T, FV-25AL9T FV-30AL7T

Automatic Shutter Louver Series

- HP (Half Pitch) condenser motor with thermal cutoff
- Well lubricated ball bearing for long life operation
- Propeller fan with advanced blade design (except FV-30AL7T)
- Automatic shutter
- Orifice equipped with oil cup
- Blind shutter louver enhances privacy and safety

Dimension

Unit : mm

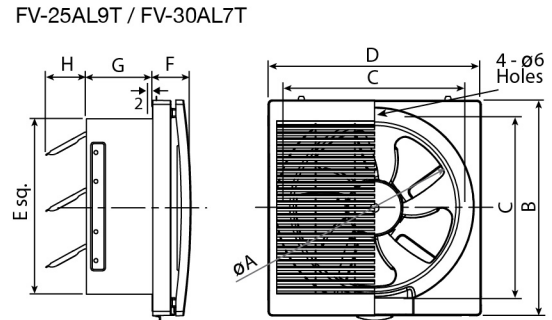
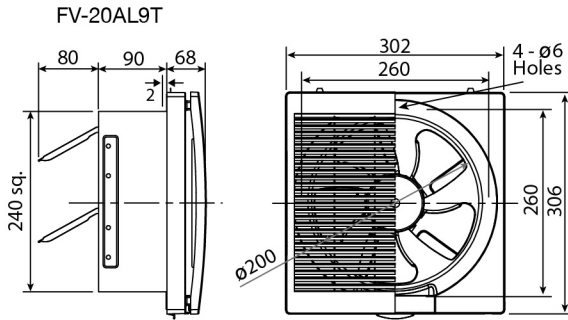

Model	A	B	C	D	E	F	G	H
FV-25AL9T	250	356	310	352	290	63	90	63
FV-30AL7T	300	406	360	402	340	63	90	78

Specification

Model No.	Voltage		Air Volume		Consumption	RPM	Noise	Weight	Installation Space
	[V]	[Hz]	[m ³ /h]	[CFM]	[W]	[min ⁻¹]	[dB(A)]	[kg]	[mm]
FV-20AL9T	220	50	546	321	20	1,190	40	2.2	250 x 250
		60	600	353	24	1,340	44		
	230	50	540	318	22	1,210	42		
FV-25AL9T	220	50	835	491	27	1,060	43	2.7	300 x 300
		60	846	498	36	1,110	43		
	230	50	840	494	30	1,105	43		
FV-30AL7T	220	50	935	550	31	880	43	3.1	350 x 350
		60	915	539	38	880	43		
	230	50	930	547	35	900	43		
	240	50	1,050	618	40	930	48		

Note : RPM data is for reference only, values may vary subject to different conditions

Test Condition

- Air volume, electric characteristic and noise are specified at the static pressure of 0 Pa
- The values of noise level is A weighted average sound pressure level, the mean value are measured by our company, within +3 to -7 dB tolerance
- The values of noise level are measured at 1 m apart from the side of fan body
- The values of air volume are the mid-points of results measured by our company, within ±10% tolerance